

ANCHORAGE STRENGTH OF STANDARD HOOKED BARS IN SIMULATED EXTERIOR BEAM- COLUMN JOINTS

By
Samir Yasso
David Darwin
Matthew O'Reilly

A Report on Research Sponsored by
Electric Power Research Institute
Concrete Steel Reinforcing Institute Education and Research
Foundation
University of Kansas Transportation Research Institute
Charles Pankow Foundation
Commercial Metals Company
Gerdau Corporation
Nucor Corporation
MMFX Technologies Corporation

Structural Engineering and Engineering Materials
SM Report No. 124
April 2017



THE UNIVERSITY OF KANSAS CENTER FOR RESEARCH, INC.
2385 Irving Hill Road, Lawrence, Kansas 66045-7563

ANCHORAGE STRENGTH OF STANDARD HOOKED BARS IN SIMULATED EXTERIOR BEAM-COLUMN JOINTS

By

Samir Yasso

David Darwin

Matt O'Reilly

A Report on Research Sponsored by

Electric Power Research Institute

Concrete Steel Reinforcing Institute Education and Research Foundation

University of Kansas Transportation Research Institute

Charles Pankow Foundation

Commercial Metals Company

Gerdau Corporation

Nucor Corporation

MMFX Technologies Corporation

Structural Engineering and Engineering Materials

SM Report No. 124

THE UNIVERSITY OF KANSAS CENTER FOR RESEARCH, INC.

LAWRENCE, KANSAS

April 2017

ABSTRACT

The current ACI hooked bar design provisions are based on test results of 38 simulated beam-column joints containing two hooked bars. The provisions address the effects of hooked bar surface condition, concrete cover, amount of confining reinforcement confining the hooks, and type of concrete (normalweight or lightweight). This study uses results of 338 simulated beam-column joint specimen tests at the University of Kansas, including two, three, or four No. 5, 8, or 11 (No. 16, 25, or 36) hooked bars with 90° or 180° hooks, along with 61 tests by others to investigate the effects of hooked bar spacing, anchoring the hooked bars outside the column core or halfway through the column depth, concrete tail cover to 90° hooks, and the effect of tail kickout at failure on hooked bar anchorage strength. In the tests performed at the University of Kansas, the center-to-center spacing between hooked bars ranged from 3 to 12 bar diameters, hooked bars were placed inside or outside column core, and hooked bars were extended to the far side of the column core or extended halfway through the column depth. Hooked bars had nominal embedment lengths ranging from 2.5 to 25.2 in. (64 to 640 mm), nominal concrete side cover ranging from 1.5 to 4 in. (38 to 100 mm) in simulated beam-column joints and 11.3 to 24.6 in. (287 to 625 mm) in walls, and nominal concrete tail cover to the hook ranging from 2 to 18 in. (50 to 460 mm). Concrete compressive strength ranged from 4,300 to 16,510 psi (30 to 114 MPa) in simulated beam-column joints and 2,400 to 5,450 psi (17 to 38 MPa) in walls, and bar stresses at anchorage failure ranged from 27,100 to 141,000 psi (187 to 972 MPa) in simulated beam-column joints and 14,200 to 60,000 psi (98 to 420 MPa) in walls.

The results show that the center-to-center spacing between hooked bars plays a role in anchorage strength up to a spacing of seven bar diameters. The closer the bars, the lower the anchorage strength per bar, in contrast with the total anchorage strength, which remains constant

or increases moderately as the number of hooked bars in a joint increases. The presence of confining reinforcement mitigates the effect of close spacing but does not eliminate it. Hooked bars placed outside the column core or anchored halfway through the column depth exhibit low anchorage strength when compared to hooked bars placed inside the column core or extended to the far side of the column. The reduction in anchorage strength ranges from 4 to 34%, producing an average anchorage strength equal to about 84% of the average strength of hooked bars placed inside the column core or extended to the far side of the column. For hooked bars with a 90° hook, concrete cover to the tail as low as 0.75 in. (29 mm) or tail kickout at failure do not affect the anchorage strength. The likelihood of tail kickout increases with increasing bar size and for hooks with tail cover less than 2 in. (50 mm) and no confining reinforcement. The results from the current analyses were used to modify a previously derived descriptive expression for hooked bar anchorage strength and a design expression for hooked bar development length. These modifications expand the applicability of the descriptive and design expressions to include the effects of hooked bar spacing, placing the hooked bar outside column core, and not extending the bar to the back of the column. Design provisions for ACI 318 are proposed.

Keywords: beam-column joints, anchorage strength, anchorage failure, hooked bars, development length, high-strength concrete, high-strength steel, reinforced concrete, hooked bar spacing, column core, tail cover, design provisions.

ACKNOWLEDGEMENTS

This report is based on a thesis presented by Samir Yasso in partial fulfillment of the requirements for the Ph.D. degree from the University of Kansas. Support for the project was provided by the Electric Power Research Institute (EPRI), Concrete Reinforcing Steel Institute Education and Research Foundation, University of Kansas Transportation Research Institute, Charles Pankow Foundation, Commercial Metals Company, Gerdau Corporation, Nucor Corporation, and MMFX Technologies Corporation. Additional materials were supplied by Dayton Superior, Midwest Concrete Materials, and W. R. Grace Construction. Thanks are due to Ken Barry and Mark Ruis, who provided project oversight for the Advanced Nuclear Technology Program of EPRI, and to Neal Anderson, Cary Kopczynski, Mike Mota, Javeed Munshi, and Conrad Paulson who served as industry advisors.

TABLE OF CONTENTS

ABSTRACT	i
ACKNOWLEDGEMENTS	iii
LIST OF FIGURES	viii
LIST OF TABLES	xiii
CHAPTER 1: INTRODUCTION	1
1.1 GENERAL	1
1.2 MECHANISM OF BOND	4
1.2.1 Types of Anchorage Tests	12
1.3 PREVIOUS WORK	17
1.4 HIGH-STRENGTH CONCRETE (HSC)	31
1.5 HIGH-STRENGTH REINFORCING STEEL	32
1.6 OBJECTIVE AND SCOPE	34
1.7 REFERENCES	36
CHAPTER 2: EFFECT OF HOOKED BAR SPACING ON ANCHORAGE STRENGTH	40
2.1 INTRODUCTION.....	40
2.2 RESEARCH SIGNIFICANCE	41
2.3 EXPERIMENTAL PROGRAM	41
2.3.1 Test Specimens	42
2.3.2 Material Properties.....	47
2.3.3 Loading System and Test Procedure.....	49
2.4 TEST RESULTS AND DISCUSSION.....	51
2.4.1 Failure Modes	51
2.4.2 Effect of Hooked Bar Spacing	52
2.4.3 Comparison with Descriptive Equations Proposed by Sperry et al. (2015b, 2017b).....	56
2.4.4 Measured total force versus calculated total force.....	63
2.5 SUMMARY AND CONCLUSIONS.....	66
2.6 REFERENCES.....	68

CHAPTER 3: EFFECT OF HOOKED BAR LOCATION AND TAIL COVER ON ANCHORAGE STRENGTH.....	70
3.1 INTRODUCTION.....	70
3.2 RESEARCH SIGNIFICANCE	71
3.3 EXPERIMENTAL PROGRAM	71
3.3.1 Test Specimens	73
3.3.2 Material Properties.....	76
3.3.3 Loading System and Test Procedure.....	78
3.4 TEST RESULTS AND DISCUSSION.....	81
3.4.1 Failure Modes	82
3.4.2 Effect of hooked bar location inside or outside the column core	83
3.4.3 Effect of hooked bar position within the column depth.....	94
3.4.4 Effect of the effective depth to embedment length ratio d_{eff}/ℓ_{eh} ratio on hooked bar anchorage strength.....	98
3.4.5 Effects of hooked bar tail cover and tail kickout	102
3.5 SUMMARY AND CONCLUSIONS.....	111
3.6 REFERENCES.....	113
CHAPTER 4: HOOKED BAR DESIGN PROVISIONS.....	115
4.1 INTRODUCTION.....	115
4.2 RESEARCH SIGNIFICANCE	116
4.3 DESIGN EXPRESSION	116
4.3.1 Closely-spaced hooked bars.....	122
4.3.2 Hooked bars outside column core or not extended to the far side of the column	126
4.3.3 Hooked bars in walls.....	129
4.4 COMPARISON WITH ACI 318-14 HOOKED BAR DESIGN EXPRESSION ..	132
4.5 PROPOSED CODE PROVISIONS.....	138
4.6 SUMMARY AND CONCLUSIONS.....	140
4.6.1 Summary	140
4.6.2 Conclusions.....	141
4.7 REFERENCES.....	141
CHAPTER 5: SUMMARY AND CONCLUSIONS	143
5.1 SUMMARY	143
5.2 CONCLUSIONS.....	144
5.3 FUTURE WORK.....	146
APPENDIX A: NOTATION AND DATA TABLES USED IN CHAPTER 2	147

APPENDIX B: NOTATION AND DATA TABLES USED IN CHAPTER 3.....222

**APPENDIX C: TEST-TO-CALCULATED RATIOS FOR SPECIMENS USED IN
CHAPTER 4.....296**

LIST OF FIGURES

Figure 1.1 Standard hooks details used in anchorage design (ACI Committee 318 2011)	2
Figure 1.2 Bond forces components (ACI Committee 408 2003)	5
Figure 1.3 Bond stresses in steel and concrete in cracked prism (Thompson et al. 2002)	6
Figure 1.4 Bond forces in steel and concrete in cracked beam within a constant moment region: (a) cracked concrete segment, (b) bond forces acting on reinforcing bar, (c) variation of tensile force in steel, (d) variation of bond force along steel (Darwin et al. 2016).....	7
Figure 1.5 Bond forces in steel and concrete in a beam subjected to shear and moment: (a) beam with flexural cracks, (b) variation of tensile force in steel along span, (c) variation of bond force per unit length along span (Darwin et al. 2016).....	8
Figure 1.6 Bond and splitting components of deformation bearing stresses (Thompson et al. 2002) ...	9
Figure 1.7 Bond failure types (a) Splitting failure (b) Shear crack and/or concrete crushing due to pullout (ACI Committee 408 2003).....	10
Figure 1.8 Behavior of 90° hooked bar subjected to tensile force (Minor 1971)	11
Figure 1.9 Pullout specimen (ACI Committee 408 2003)	12
Figure 1.10 Beam-end specimen (Minor 1971).....	13
Figure 1.11 Simulated beam-column joint test specimen (Marques 1973)	14
Figure 1.12 Beam test specimens (Ferguson and Thompson 1962)	15
Figure 1.13 Beam-column specimen details (Hansen and Connor 1967).....	16
Figure 1.14 Complete stress-strain curves for concrete (ACI Committee 363 1992).....	32
Figure 1.15 Typical stress-strain curves for reinforcing steel (Darwin et al. 2016)	33
Figure 2.1 Schematic of test specimens (a) side view of specimen (b) cross-section of specimen with two hooks with confining reinforcement (c) cross-section of specimen with three hooks with confining reinforcement (d) cross-section of specimen with four hooks with confining reinforcement.....	43
Figure 2.2 Specimen designation	43
Figure 2.3 Test frame	50
Figure 2.4 Failure modes (a) Front (F) (b) front (F) with side (S), and (c) Tail Kickout (TK) ...	52
Figure 2.5a Normalized anchorage force per bar at failure T_N versus center-to-center spacing of hooked bars without confining reinforcement	54

Figure 2.5b Normalized anchorage force per bar at failure T_N versus column width of hooked bars without confining reinforcement	54
Figure 2.6 Normalized anchorage force per bar at failure T_N versus center-to-center spacing for hooked bars with five No. 3 (No. 10) hoops as confining reinforcement.....	56
Figure 2.7 Ratio of test-to-calculated force T/T_h versus center-to-center spacing normalized to bar diameter c_{ch}/d_b for specimens with widely and closely-spaced hooked bars without confining reinforcement, with calculated values based on Eq. (2.1)	57
Figure 2.8 Ratio of test-to-calculated force T/T_h versus center-to-center spacing normalized to bar diameter c_{ch}/d_b for specimens with widely and closely-spaced hooked bars without confining reinforcement, calculated values based on Eq. (2.3)	59
Figure 2.9 Ratio of test-to-calculated force T/T_h versus center-to-center spacing normalized to bar diameter c_{ch}/d_b for specimens with widely and closely-spaced hooked bars with confining reinforcement, calculated values based on Eq. (2.3)	60
Figure 2.10 Ratio of test-to-calculated force T/T_h versus center-to-center spacing normalized to bar diameter c_{ch}/d_b for specimens with widely and closely-spaced hooked bars with confining reinforcement, calculated values based on Eq. (2.7)	62
Figure 3.1 Schematic of typical specimen (a) side view of specimen (b) cross-section of specimen with two hooks inside the column core with confining reinforcement (c) cross-section of specimen with three hooks outside the column core with confining reinforcement.....	74
Figure 3.2 Schematic of specimen with hooked bar extended halfway through the column depth (a) side view of specimen (b) cross-section of specimen with two hooks inside the column core with confining reinforcement (c) cross-section of specimen with three hooks inside the column core with confining reinforcement (d) cross-section of specimen with four hooks inside the column core with confining reinforcement.....	75
Figure 3.3 Example specimen designation	75
Figure 3.4a Test frame for two hooked bar specimens.....	79
Figure 3.5 Failure modes (a) Front Failure (F) (b) Side Failure (S) (c) Tail kickout (TK)	82

Figure 3.6 Ratio $(T_{\text{outside}}/T_{\text{inside}})_N$ for specimens with hooked bars inside and outside the column core (specimens listed in Table 3.5)	86
Figure 3.7 Inside versus outside the column core comparison for specimens in Groups 1 to 4 in Table 3.5	88
Figure 3.8 Dominant mode of failure for specimens with hooked bars placed inside vs outside the column core in Table 3.5	89
Figure 3.9 Percent of hooked bars exhibiting front or side failure for specimens in.....	93
Figure 3.10 Percent of hooked bars exhibiting front or side failure for specimens in Table 3.6 based on the absence or presence of confining reinforcement and hooked bar location.....	94
Figure 3.11 Representation of effective depth d_{eff} and compression stress block	99
Figure 3.12 T/T_c and T/T_h versus d_{eff}/ℓ_{eh} for closely-spaced hooked bar specimens (a) without and (b) with confining reinforcement in Tables 3.7 and 3.8 and widely-spaced hooked bar specimens in Appendix B.....	101
Figure 3.13 Tail cover distribution for hooked bars used in current study (1 in. = 25 mm).....	104
Figure 3.14 T_{ind}/T_h for hooked bars with concrete tail cover to the hook less than 2 in. (50 mm) and hooks with tail kickout (TK).....	109
Figure 3.15 Percent of hooked bars inside and outside the column core exhibiting tail kickout with concrete tail cover less < 2 in. (50 mm) and tail cover \geq 2 in. (50 mm).....	110
Figure 4.1 Region over which confining reinforcement is effective for 90° and 180° hooks	118
Figure 4.2 Measured versus calculated bar failure load for specimens containing two widely-spaced hooked bars without confining reinforcement, with T_h based on Eq. (4.1)	121
Figure 4.3 Measured versus calculated bar failure load for specimens containing two widely-spaced hooked bars with confining reinforcement, with T_h based on Eq. (4.1)	122

Figure 4.4 Measured versus calculated bar failure load for hooked bars without confining reinforcement, including specimens with closely-spaced hooked bars, with T_h based on Eq. (4.8).....	124
Figure 4.5 Measured versus calculated bar failure load for hooked bars with confining reinforcement, including multiple-hook specimens, with T_h based on Eq. (4.8).....	125
Figure 4.6 Measured versus calculated bar failure load for hooked bars without confining reinforcement, including two- and multiple-hook specimens outside the compression region, and specimens with hooked bars outside the column core, with T_h based on Eq. (4.9).....	127
Figure 4.7 Measured versus calculated bar failure load for hooked bars with confining reinforcement, including two- and multiple-hook specimens outside the compression region, and specimens with hooked bars outside the column core, with T_h based on Eq. (4.9).....	129
Figure 4.8 Measured versus calculated bar failure load for hooked bars without confining reinforcement, including hooks embedded in walls, with T_h based on Eq. (4.9).....	131
Figure 4.9 Test-to-calculated strength ratios T/T_h for ACI 318-14 and proposed provisions for specimens with two widely-spaced hooked bars without confining reinforcement	134
Figure 4.10 Test-to-calculated strength ratios T/T_h for ACI 318-14 and proposed provisions for specimens with two widely-spaced hooked bars with confining reinforcement	135
Figure A.1 Longitudinal column reinforcement-4 No. 5 bars. Transverse reinforcement not shown.....	149
Figure A.2 Longitudinal column reinforcement-4 No. 8 bars. Transverse reinforcement not shown...	149
Figure A.3 Longitudinal column reinforcement-5 No. 8 bars. Transverse reinforcement not shown	150
Figure A.4 Longitudinal column reinforcement-6 No. 5 bars. Transverse reinforcement not shown. ...	150
Figure A.5 Longitudinal column reinforcement-5 No. 5 bars + 1 No. 3 bar. Transverse reinforcement not shown.....	151
Figure A.6 Longitudinal column reinforcement-4 No. 8 bars + 2 No. 5 bars. Transverse reinforcement not shown.....	151
Figure A.7 Longitudinal column reinforcement-6 No. 8 bars. Transverse reinforcement not shown. ...	152
Figure A.8 Longitudinal column reinforcement-4 No. 8 bars + 2 No. 11 bars. Transverse reinforcement not shown.....	152
Figure A.9 Longitudinal column reinforcement-8 No. 5 bars. Transverse reinforcement not shown. ...	153
Figure A.10 Longitudinal column reinforcement-8 No. 8 bars (four bundles of two bars each). Transverse reinforcement not shown.	153
Figure A.11 Longitudinal column reinforcement-8 No. 8 bars (distributed across two column faces). Transverse reinforcement not shown.	154

Figure A.12 Longitudinal column reinforcement-8 No. 8 bars (distributed across four column faces). Transverse reinforcement not shown.	154
Figure A.13 Longitudinal column reinforcement-4 No. 8 bars + 4 No. 11 bars. Transverse reinforcement not shown.....	155
Figure A.14 Longitudinal column reinforcement-10 No. 8 bars. Transverse reinforcement not shown. . .	155
Figure A.15 Longitudinal column reinforcement-8 No. 8 bars + 2 No. 5 bars. Transverse reinforcement not shown.....	156
Figure A.16 Longitudinal column reinforcement-12 No. 8 bars. Transverse reinforcement not shown. . .	156
Figure B.1 Longitudinal column reinforcement-4 No. 5 bars. Transverse reinforcement not shown...224	
Figure B.2 Longitudinal column reinforcement-4 No. 8 bars. Transverse reinforcement not shown. . .	224
Figure B.3 Longitudinal column reinforcement-5 No. 8 bars. Transverse reinforcement not shown.	225
Figure B.4 Longitudinal column reinforcement-6 No. 5 bars. Transverse reinforcement not shown.	225
Figure B.5 Longitudinal column reinforcement-5 No. 5 bars + 1 No. 3 bar. Transverse reinforcement not shown.....	226
Figure B.6 Longitudinal column reinforcement-4 No. 8 bars + 2 No. 5 bars. Transverse reinforcement not shown.....	226
Figure B.7 Longitudinal column reinforcement-6 No. 8 bars. Transverse reinforcement not shown.	227
Figure B.8 Longitudinal column reinforcement-4 No. 8 bars + 2 No. 11 bars. Transverse reinforcement not shown.....	227
Figure B.9 Longitudinal column reinforcement-8 No. 5 bars. Transverse reinforcement not shown.	228
Figure B.10 Longitudinal column reinforcement-8 No. 8 bars (four bundles of two bars each). Transverse reinforcement not shown.	228
Figure B.11 Longitudinal column reinforcement-8 No. 8 bars (distributed across two column faces). Transverse reinforcement not shown.	229
Figure B.12 Longitudinal column reinforcement-8 No. 8 bars (distributed across four column faces). Transverse reinforcement not shown.	229
Figure B.13 Longitudinal column reinforcement-4 No. 8 bars + 4 No. 11 bars. Transverse reinforcement not shown.....	230
Figure B.14 Longitudinal column reinforcement-10 No. 8 bars. Transverse reinforcement not shown. . .	230

Figure B.15 Longitudinal column reinforcement-8 No. 8 bars + 2 No. 5 bars. Transverse reinforcement not shown..... 231

Figure B.16 Longitudinal column reinforcement-12 No. 8 bars. Transverse reinforcement not shown. . .231

LIST OF TABLES

Table 2.1 Test parameters for specimens with three or four closely-spaced hooked bars without confining reinforcement*	45
Table 2.2 Test parameters for specimens with three or four closely-spaced hooked bars with confining reinforcement*	46
Table 2.3 Concrete mixture proportions	48
Table 2.4 Hooked bar properties	49
Table 2.5 Location of reaction forces	50
Table 2.6 Ratio of test-to-calculated force T/T_h for specimens closely and widely-spaced hooked bars with calculated values T_h based on Eq. (2.7)	63
Table 2.7 Measure versus calculated forces calculated forces using Eq. 2.1 for specimens in Table 2.1 and 2.2	65
Table 2.8 Summary of results in Table 2.7 showing mean, maximum, and minimum of $T_{total}/2T_h$ and T/T_h	66
Table 3.1 Concrete mixture proportions	77
Table 3.2 Hooked bar properties	78
Table 3.3 Location of reaction forces	80
Table 3.4 Groups* with hooked bars inside and outside the column core	83
Table 3.5 Test results for Groups 1 to 4 with hooked bars inside and outside the column core..	85
Table 3.6 Statistical parameters of T/T_h for hooked bars inside and outside the column core with T_h based on Eq. (3.2)	90
Table 3.7 Specimens with hooked bars extended halfway through the column depth (all hooked bars exhibited front failure) ^a	95
Table 3.8 Specimens with multiple hooked bars extended halfway through the column depth ^a .	97
Table 3.9 Statistical parameters of T_{ind}/T_h (T/T_h) for individual hooked bars and specimens inside and outside the column core with T_h based on Eq. (3.2)	106
Table 3.10 Hooked bars exhibited tail kickout based on the bar size	111
Table 4.1a Values of ψ_r for hooked bars with $f_y = 60,000$ psi (420 MPa) confined by No. 3 (No. 10) bars...	119

Table 4.1b Values of ψ_r for hooked bars with $f_y = 80,000$ psi (550 MPa) confined by No. 3 (No. 10) bars	119
Table 4.1c Values of ψ_r for hooked bars with $f_y = 100,000$ psi (690 MPa) confined by No. 3 (No. 10) bars	119
Table 4.2 Statistical parameters for test-to-calculated forces (T/T_h) for closely-spaced hooked bar specimens without and with confining reinforcement in Figure 4.4 and 4.5.....	125
Table 4.3 Measured versus calculated bar failure loads for hooked bars in walls tested by Johnson and Jirsa (1981), with T_h based on Eq. (4.9).....	131
Table 4.4 Statistical parameters of the test-to-calculated strength ratio T/T_h for specimens with two widely-spaced hooked bars shown in Figures 4.9 and 4.10.....	136
Table 4.5 Statistical parameters of the test-to-calculated strength ratio T/T_h for specimens with closely-spaced hooked bars, with hooked bars outside column core, and hooked bars extended halfway through column depth	137
Table A.1 Comprehensive test results and data for No. 5 specimens with two hooks	157
Table A.2 Comprehensive test results and data for No. 8 specimens with two hooks	170
Table A.3 Comprehensive test results and data for No. 11 specimens with two hooks	192
Table A.4 Comprehensive test results and data for No. 5 specimens with closely-spaced hooks.....	204
Table A.5 Comprehensive test results and data for No. 8 specimens with closely-spaced hooks.....	210
Table A.6 Comprehensive test results and data for No. 11 specimens with closely-spaced hooks ...	220
Table B.1 Comprehensive test results and data for No. 5 specimens with two hooks	232
Table B.2 Comprehensive test results and data for No. 8 specimens with two hooks.....	244
Table B.3 Comprehensive test results and data for No. 11 specimens with two hooks.....	266
Table B.4 Comprehensive test results and data for No. 5 specimens with closely-spaced hooks.....	278
Table B.5 Comprehensive test results and data for No. 8 specimens with closely-spaced hooks.....	284
Table B.6 Comprehensive test results and data for No. 11 specimens with closely-spaced hooks	294
Table C.1 Test-to-calculated ratios for specimens with two widely-spaced hooked bars without confining reinforcement	296
Table C.2 Test-to-calculated ratios for specimens with two widely-spaced hooked bars with confining reinforcement.....	298

Table C.3 Test-to-calculated ratios for specimens with closely-spaced hooked bars without confining reinforcement.....	302
Table C.4 Test-to-calculated ratios for specimens with closely-spaced hooked bars with confining reinforcement	303
Table C.5 Test-to-calculated ratios for specimens with hooked bars outside column core.....	304
Table C.6 Test-to-calculated ratios for specimens with hooked bars extended halfway through the column depth.....	305
Table C.7 Test-to-calculated ratios for specimens without confining reinforcement from other researchers.....	306
Table C.8 Test-to-calculated ratios for specimens with hooked bars embedded in walls	307

CHAPTER 1: INTRODUCTION

1.1 GENERAL

Reinforced concrete is a widely used material in structures. Concrete, the main material in these structures, is brittle, strong in compression, and weak in tension. Because of the high tensile and compressive strength of reinforcing steel compared to that of concrete, steel bars or wires are used whenever stresses (especially tensile stresses) cannot be resisted by concrete alone, or to prevent brittle failure after the concrete cracks. For reinforced concrete to act as a composite material, concrete and reinforcing steel must have adequate bond so that the two materials will deform together to carry load. For example, in members subjected to bending, the existence of a bond force (or force transfer) is essential to maintain equilibrium between the concrete in the compression zone and the reinforcement carrying the tensile force. Extending the reinforcing bar beyond the location of maximum stress demand or using hooks or heads at the ends of reinforcing bars to provide mechanical anchorage are ways to transfer the force from the steel to the surrounding concrete and provide the required equilibrium between the two materials.

Extending straight bars beyond the point of maximum stress demand is the simplest way to provide anchorage. The choice between using straight bars or end-anchored bars to transfer forces between steel and concrete will depend mainly on the space available for the bar to be extended beyond the point of maximum stress. Concrete compressive strength, steel bar yield strength, the distance from the bar surface to the face of the concrete member or the spacing between bars, and the amount of confining reinforcement available at that region are some of the factors that affect the required extended length. When sufficient length is not available, hooks or heads are used to shorten the length required to transfer the forces. The use of these types of anchorages implies that the mechanism of force transfer at the end of the bar is different from that of straight bars.

“Standard Hook” is a terminology used in the ACI 318 Building Code (2014) to describe a hooked bar that has a certain radius of bend and tail extension after the bend, as shown in Figure 1.1 (ACI Committee 318 2011). The design equation at Section 25.4.3.1 (a) in ACI 318-14 (ACI Committee 318 2014) to calculate the required embedment length of hooked bars, is applicable to “standard hooks”, which can have 90° or 180° bends.

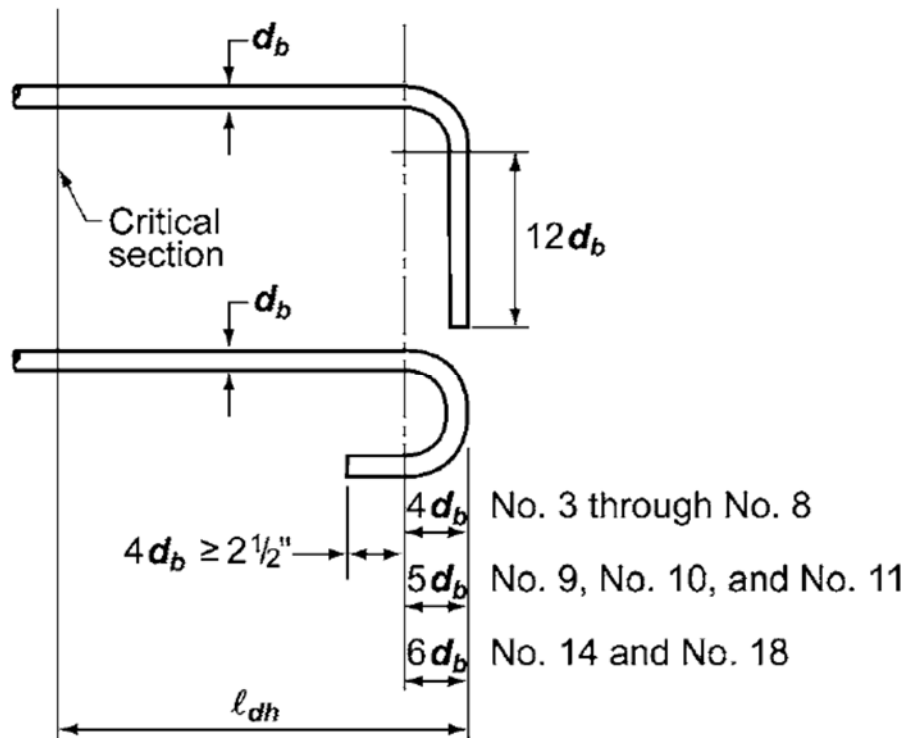

Figure 1.1 Standard hooks details used in anchorage design (ACI Committee 318 2011)

The design equation in ACI 318-14 indicates that the development length of a hooked bar ℓ_{dh} is a function of the yield strength of the bar f_y , the square root of concrete compressive strength f'_c , and diameter of the bar d_b . The equation for calculating the development length of hooked bars in ACI 318-14 is

$$\ell_{dh} = \left(\frac{f_y \Psi_e \Psi_c \Psi_r}{50 \lambda \sqrt{f'_c}} \right) d_b \quad (1.1)$$

where λ , ψ_e , ψ_c , and ψ_r are embedment length modification factors for Eq. (1.1) per ACI 318-14, Table 25.4.3.2 for using lightweight concrete, epoxy-coated bars, concrete cover, and confining reinforcement respectively.

The provisions in the ACI Building Code state that the value of concrete compressive strength in Eq. (1.1) must not be taken greater than 10,000 psi (69 MPa). Equation (1.1) was developed based on a limited number of tests of standard hooked bars: 38 simulated beam-column joints by Marques and Jirsa (1975) and Pinc et al. (1977) with concrete compressive strengths below 5,600 psi (39 MPa) and steel yield strengths of 68,000 psi (469 MPa) or less. As a result, the provisions for development length of hooked bars do not accurately reflect the observed behavior of all anchorage tests, and the equation limits taking advantage of concrete strengths higher than 10,000 psi (69 MPa). This limitation caps the effect of concrete compressive strength on anchorage strength, preventing designers from using higher compressive strengths to increase the anchorage capacity when needed. The ACI Building Code permits the use of Eq. (1.1) for concrete compressive strengths up to 10,000 psi (69 MPa) (without cap) and steel with yield strengths up to 80,000 psi (550 MPa), but these two limits were never tested to calibrate Eq. (1.1). Also, the tests used to develop Eq. (1.1) did not account for the possibility of having more than two hooked bars or using closely spaced hooked bars, both of which are common. This study expands the current database and covers the gaps in the earlier work. This is accomplished by investigating the effects of high strength concrete, high strength steel, different bar sizes, different side covers, and different confining transverse reinforcement configuration within the joint region on the anchorage strength of hooked bars.

This chapter explains the mechanisms of bond between reinforcing steel and concrete, describes previous studies, including those used to develop the current ACI Building Code hooked bar design provisions, and presents the object and scope of the study.

1.2 MECHANISM OF BOND

When smooth bars were commonly used as reinforcement, the main mechanism of force transfer was through adhesion and friction (Darwin et al. 2016). These two forces can be lost soon after a bar is subjected to tension because of the reduction in bar cross section associated with bar elongation under the applied load. When adhesion and friction are lost, the bond between steel and concrete is lost and the beam collapses. To overcome this limitation for smooth bars, mechanical end anchorage was provided in form of hooks. The combination of uncracked concrete in the compression zone of the beam (representing the arch) and a hooked bar (representing a tie) forms a tied arch that prevents the beam from collapse if sufficient anchorage is provided. When bond along the surface of smooth bars is lost, the elongation of the steel increases, leading to larger crack widths and larger deflections (Darwin et al. 2016).

Due to the limited bond strength of smooth bars, deformed bars are used in modern reinforced concrete construction. Deformations on the bar provide a bearing area that helps to transfer forces from the steel to the surrounding concrete, increasing bond forces beyond the adhesion and friction forces along the surface of the bar, as shown in Figure 1.2. If sufficient development length is available to anchor the tensile force in the bar, there is no need to have mechanical anchorage at the end of the beam. If this is not the case, the end of the bar must be anchored (using hooks or heads) to provide an additional mechanism (bearing) to “develop” the

force in the steel bar. This document addresses the anchorage of deformed bars unless otherwise indicated.

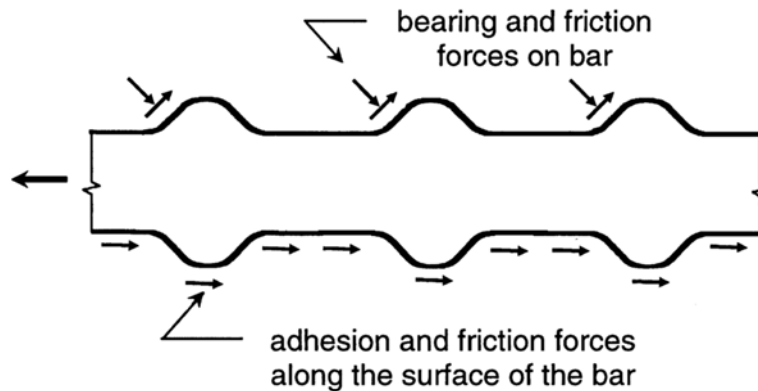

Figure 1.2 Bond forces (ACI Committee 408 2003)

Due to the uneven distribution of cracks in reinforced concrete members, the distribution of bond forces along a reinforcing bar is very complex. In a cracked concrete member subjected to tension, tensile stresses in concrete are zero and stresses in the steel bars are largest where the cracks are located (Darwin et al. 2016). While the bond stresses are zero at crack locations, these stresses become largest near the crack location and decrease as the concrete carries tensile stresses away from the crack. If the demand on the steel is sufficiently large, bars will yield locally near the crack locations (Thompson et al. 2002). Also, the non-uniform distribution of the bond stresses along the length of the reinforcing bar causes higher bond stresses at rib bearing locations that can be twice as large as the average bond stress (Mains 1951). Figure 1.3 shows the distribution of stresses in the concrete and deformed steel bar in a reinforced concrete member subjected to direct tension.

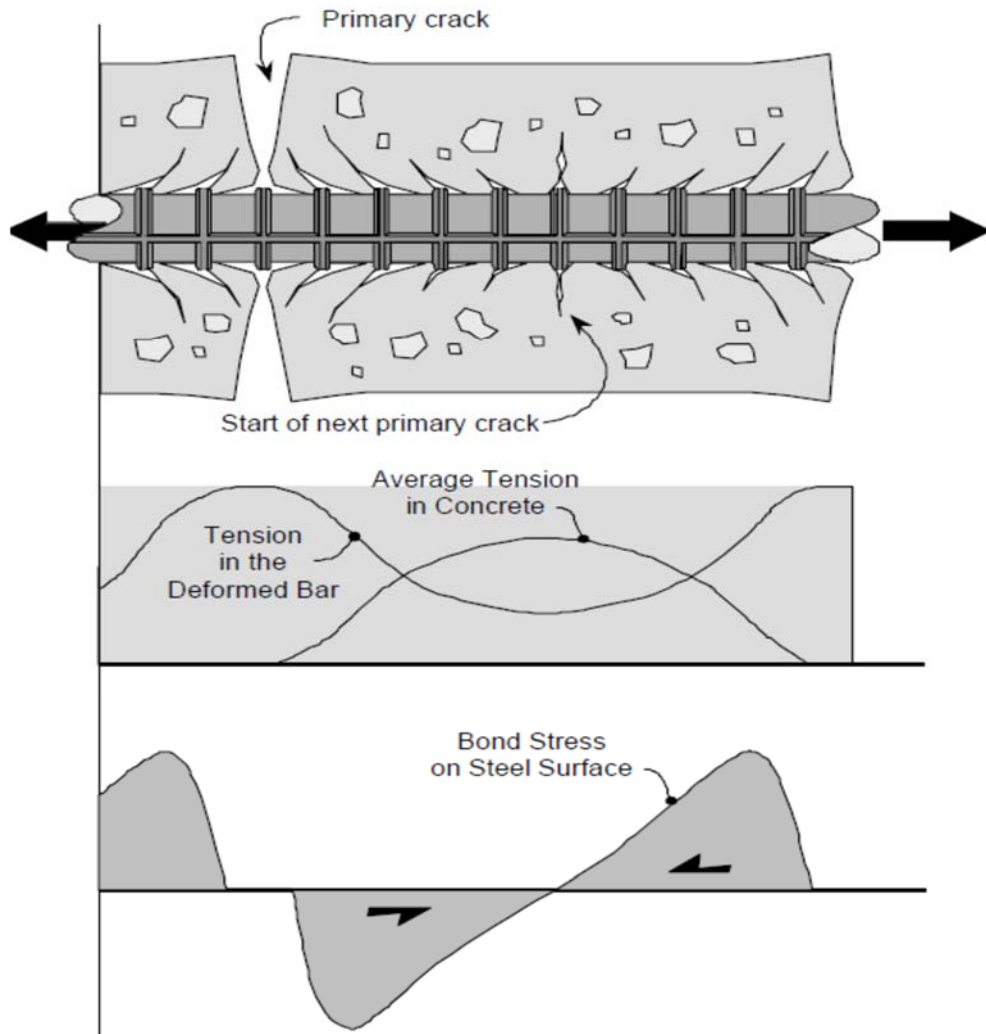

Figure 1.3 Bond stresses in steel and concrete in cracked prism (Thompson et al. 2002)

Most of the time in reinforced concrete beams, loading conditions are such that beams carry a combination of bending moment and shear. Figure 1.4 shows the variation of steel, concrete, and bond stresses in a constant moment region. Cracks form when concrete fails to resist the tensile stresses (Figure 1.4a). Tension in the steel is greatest where the cracks are located and can be computed using cracked section theory (Figure 1.4c). The bond force between the cracks will vary as shown in Figure 1.4d. Very high local bond forces have been measured adjacent to the cracks

during tests (Mains 1951). The bond force is proportional to the rate of change of the bar force. It is highest where the slope of the steel force curve is greatest, and it is zero where the slope is zero (Darwin et al. 2016). Also, in a constant moment region, the average bond force between two cracks is zero.

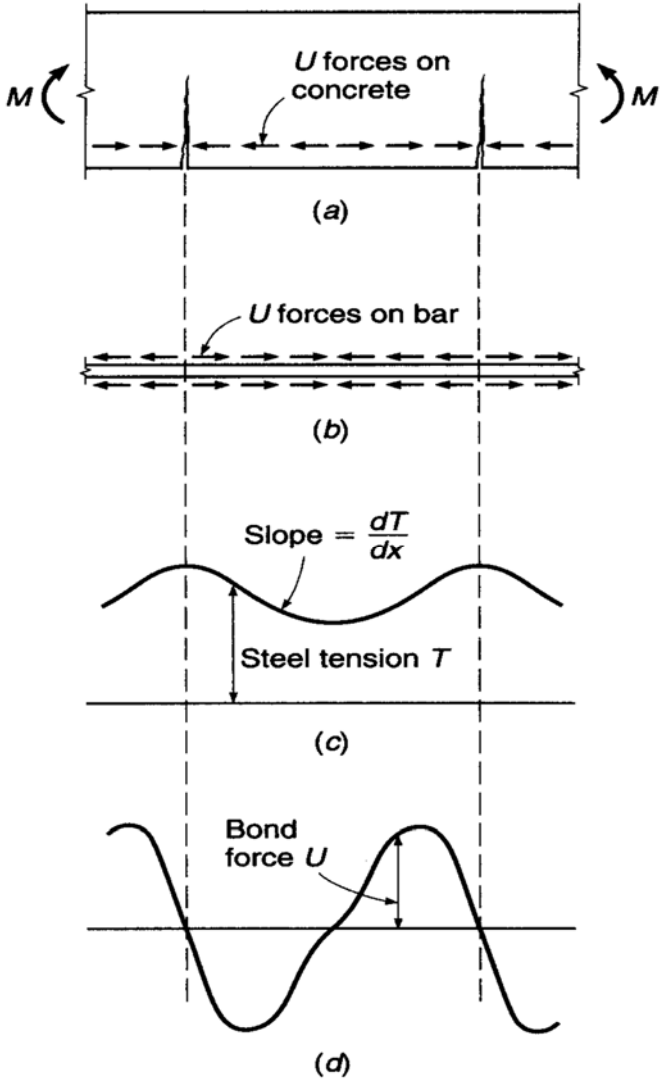

Figure 1.4 Bond forces in steel and concrete in cracked beam within a constant moment region: (a) cracked concrete segment, (b) bond forces acting on reinforcing bar, (c) variation of tensile force in steel, (d) variation of bond force along steel (Darwin et al. 2016)

Beams are usually subjected to transverse loading, which causes shear in addition to bending and, thus, rarely are under pure bending. Figure 1.5a shows a beam subjected to transverse loading.

Figure 1.5b shows that the steel force calculated using cracked section theory is proportional to the moment diagram and can only predict the actual steel force accurately at crack locations. Otherwise, the actual steel force is less than the force predicted using cracked section theory. The actual distribution for the bond force is shown in Figure 1.5c, where bond forces are higher at regions with high shear (Darwin et al. 2016). Also, the total area of the bond force diagram at the shear region (variable moment region), is not equal to zero.

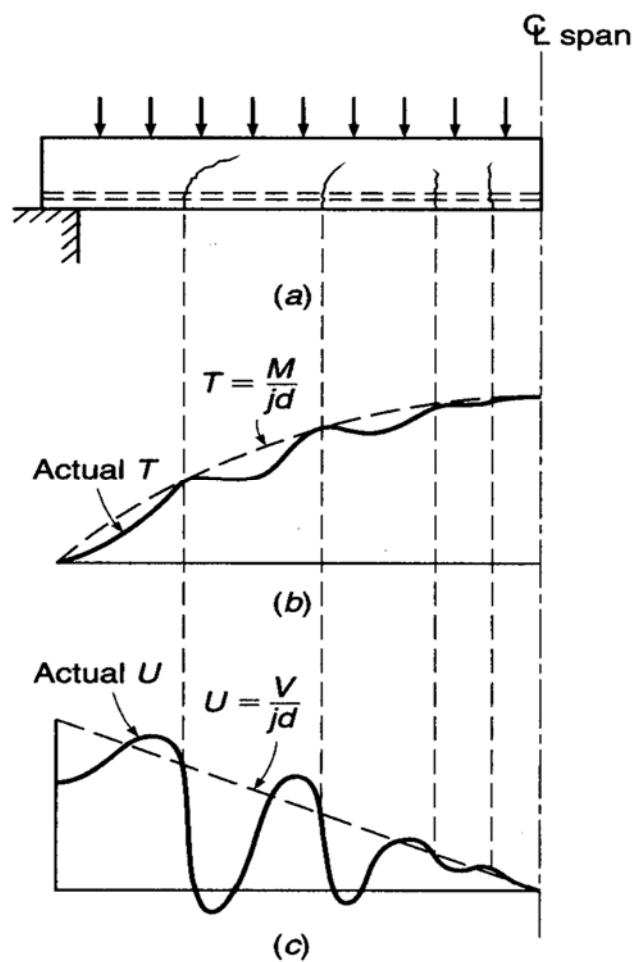

Figure 1.5 Bond forces in steel and concrete in a beam subjected to shear and moment: (a) beam with flexural cracks, (b) variation of tensile force in steel along span, (c) variation of bond force per unit length along span (Darwin et al. 2016)

At the bar deformations, bearing forces in the concrete act at an angle θ_{bond} with respect to the longitudinal axis of the bar (Figure 1.6). The bearing forces have two components, parallel and

perpendicular to the bar. The component parallel to the bar creates the bond required to resist the tensile force in the bar. The component perpendicular to the bar acts as radial splitting force on the concrete and is resisted by the tensile capacity provided by the concrete surrounding the bar. When the radial stresses exceed the tensile capacity of the concrete, a splitting failure will take place.

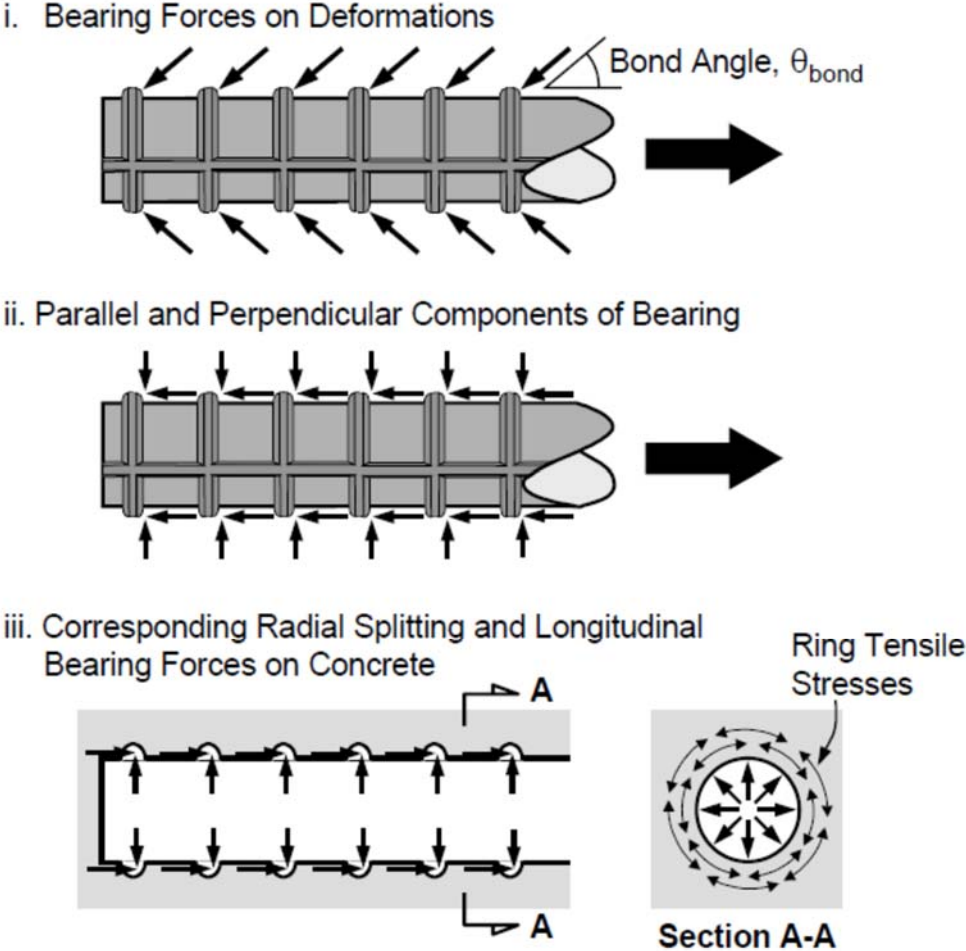

Figure 1.6 Bond and splitting components of deformation bearing stresses (Thompson et al. 2002)

Figure 1.7 shows two different failure modes associated with bond of straight bars: splitting failure due to the radial tensile stresses on concrete and pullout failure due to concrete crushing in

front of the bar deformations. The prevailing mode of failure will depend on the bar spacing and cover dimensions (Thompson et al. 2002). Splitting failure occurs when the spacing between the bars and/or the cover to the member surface are relatively small. When the space between the bars and the cover are large compared with the bar diameter, a splitting failure will be prevented and a pullout failure will occur instead. In this case, the stresses along the bar exceed the shear capacity of the concrete between bar deformations and shear cracks will develop parallel to the bar or concrete will crush at the faces of the deformations. If the embedment length, bar spacing, and cover are large enough to prevent these two failure modes, failure may occur due to yielding of the reinforcing bar, which is not considered to be bond failure.

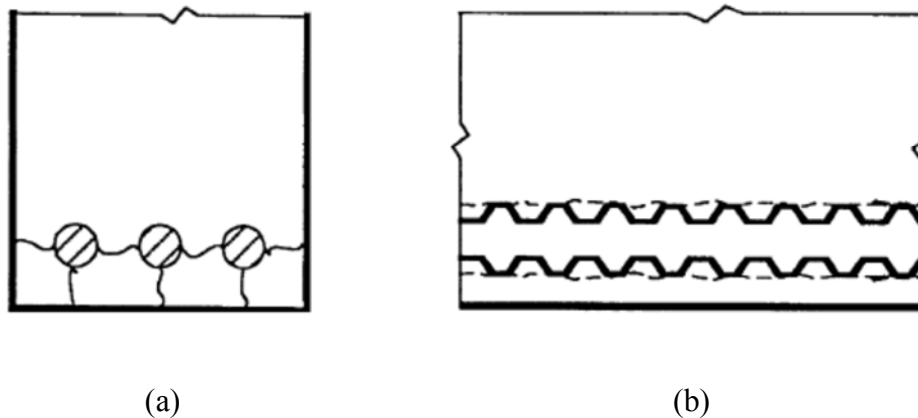

Figure 1.7 Bond failure types (a) Splitting failure (b) Shear crack and/or concrete crushing due to pullout (ACI Committee 408 2003)

The previous discussion describes the bond failure mechanism for straight bars. For hooked bars, the behavior differs due to the presence of the hook. The anchorage capacity of a hook is mobilized as slip between the straight portion of the bar and the concrete takes place. Figure 1.8 illustrates the anchorage behavior of a 90° hooked bar. When slip takes place in the straight portion of the bar, the hook loses bond with the concrete along the outer radius and the concrete along the

inner radius is subjected to compressive stresses. If these compressive stresses become sufficiently large, they can cause crushing of the concrete due to bearing along the inner radius of the hook. There is a significant difference between the modes of failure of 90° and 180° hooks. Ninety-degree hooked bars tend to straighten when subjected to tension, causing a portion of the hook tail along the outside to bear against the concrete. When the tail cover is sufficiently small, the hook tail can “kickout” the concrete cover, causing the concrete to spall, although there is little if any evidence that a kickout failure has much effect on the anchorage capacity of a hooked bar. One hundred eighty-degree hooked bars tend to move as whole and lead to crushing of concrete inside the curved portion of the hook. (Jirsa and Marques 1972, Minor 1971, Minor and Jirsa 1975, Podhorsky 2011).

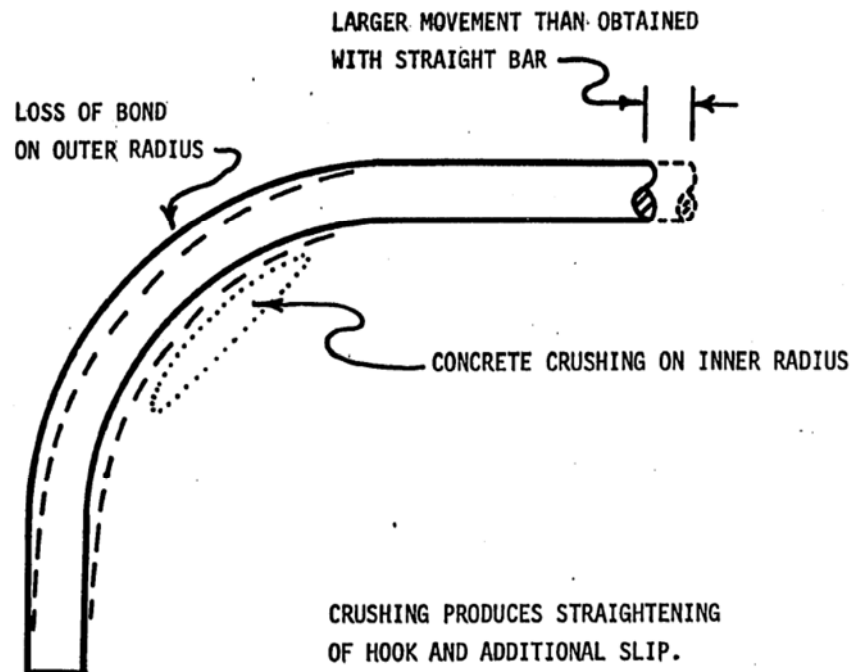

Figure 1.8 Behavior of 90° hooked bar subjected to tensile force (Minor 1971)

1.2.1 Types of Anchorage Tests

Several different methods have been used to test the anchorage strength of straight, hooked, and headed bars. Methods to test the anchorage strength of hooked bars can be classified into:

1. Pullout tests: The bars in a pullout specimen are embedded in a concrete block and pulled until failure. Figure 1.9 shows a pullout specimen, where the bar is placed in tension and the face of concrete is placed in compression. This type of specimen is easy to fabricate, the test is simple, and it has been widely used. The test configuration results in compressive struts from the support points of the concrete and the reinforcing bar surface, which places the bar surface in compression. The stress state in a pullout specimen differs from most reinforced concrete structures, however, which makes the test the least realistic of bond tests (ACI Committee 408 2003). Pullout tests were performed by Abrams (1913) for plain bar hooked bars. Fishburn (1947) tested hooked bars embedded in lightweight concrete. This type of test configuration was also used by Menzel (1941), Menzel (1952), and Hribar and Vasko (1969).

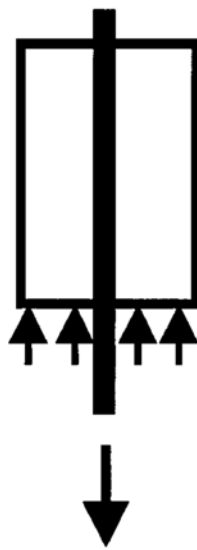

Figure 1.9 Pullout specimen (ACI Committee 408 2003)

2. Beam-end tests: Figure 1.10 shows a beam-end specimen, where reinforcing bars are embedded in a concrete block and subjected to tension. In beam-end specimens, the reinforcing bars and the surrounding concrete are simultaneously placed in tension and the compression force (reaction) is located away from the reinforcing bars to achieve the desired stress state. This differs from pullout specimens in which concrete adjacent to the reinforcing bars is under compression. These tests were performed by Mylrea (1928) for plain hooked bars. This type of test configuration was also used by Minor (1971) and Minor and Jirsa (1975). Figure 1.10 shows the beam-end specimen used by Minor (1971). Beam-end specimens containing hooked bars are simple and provide results for bond strength that generally match those obtained using specimens designed to represent full-scale reinforced concrete members. The specimens are usually reinforced to ensure bond failure and prevent other failure modes, such as shear and flexure (ACI Committee 408 2003).

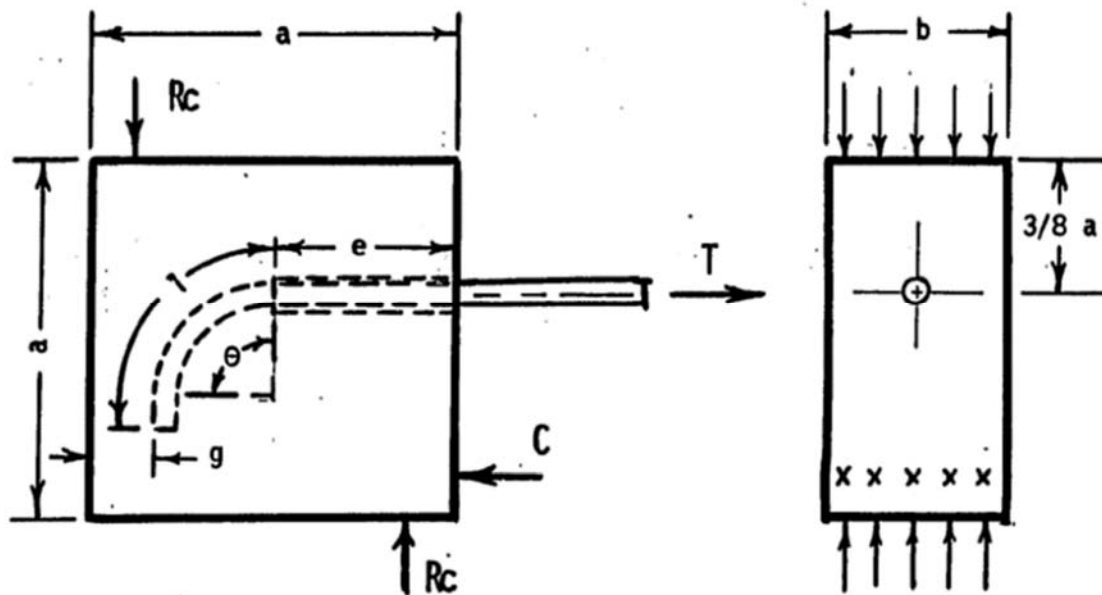

Figure 1.10 Beam-end specimen (Minor 1971)

3. Simulated beam-column joints: This type of specimen was used by Marques (1972), Marques (1973), Pinc et al. (1977), Soroushian et al. (1988), Hamad et al. (1993), Joh et al. (1995), Joh and Shibata (1996), and Ramirez and Russell (2008). Similar work performed by Johnson and Jirsa (1981) and Joh et al. (2001) to simulate hooks embedded in walls can be included in the specimen category. Figure 1.11 illustrates the simulated beam-column specimen used by Marques (1973).

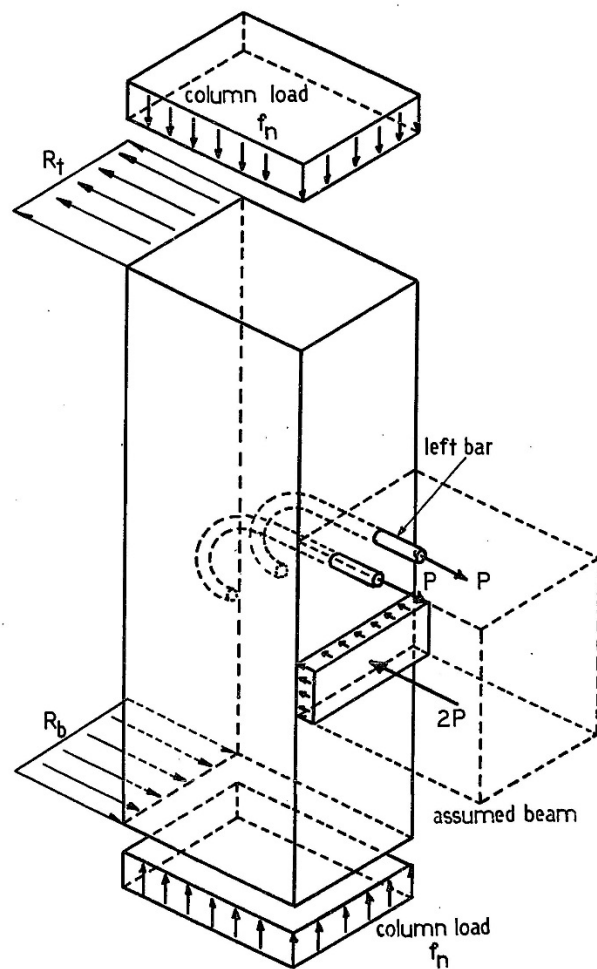

Figure 1.11 Simulated beam-column joint test specimen (Marques 1973)

4. Beam tests: Beam specimens containing straight or bent bar anchorages have been widely used by researchers to determine the influence of anchorage strength on the shear and moment capacity of beams. Taub and Neville (1960) performed beam tests containing plain hooked bars. Ferguson and Thompson (1962) performed experiments to evaluate the capacity of beams with end hooked anchorages compared with that of straight bar anchorages. Menzel and Woods (1952) reported that the capacity of deformed hooked bars was higher than that of plain hooked bars. Figure 1.12 shows beam specimens tested by Ferguson and Thompson (1962). Splice tests are also performed using beam specimens. Many researchers have tested beams containing supplies such as Ferguson and Breen (1965), Darwin et al. (1996a), and Zuo and Darwin (2000).

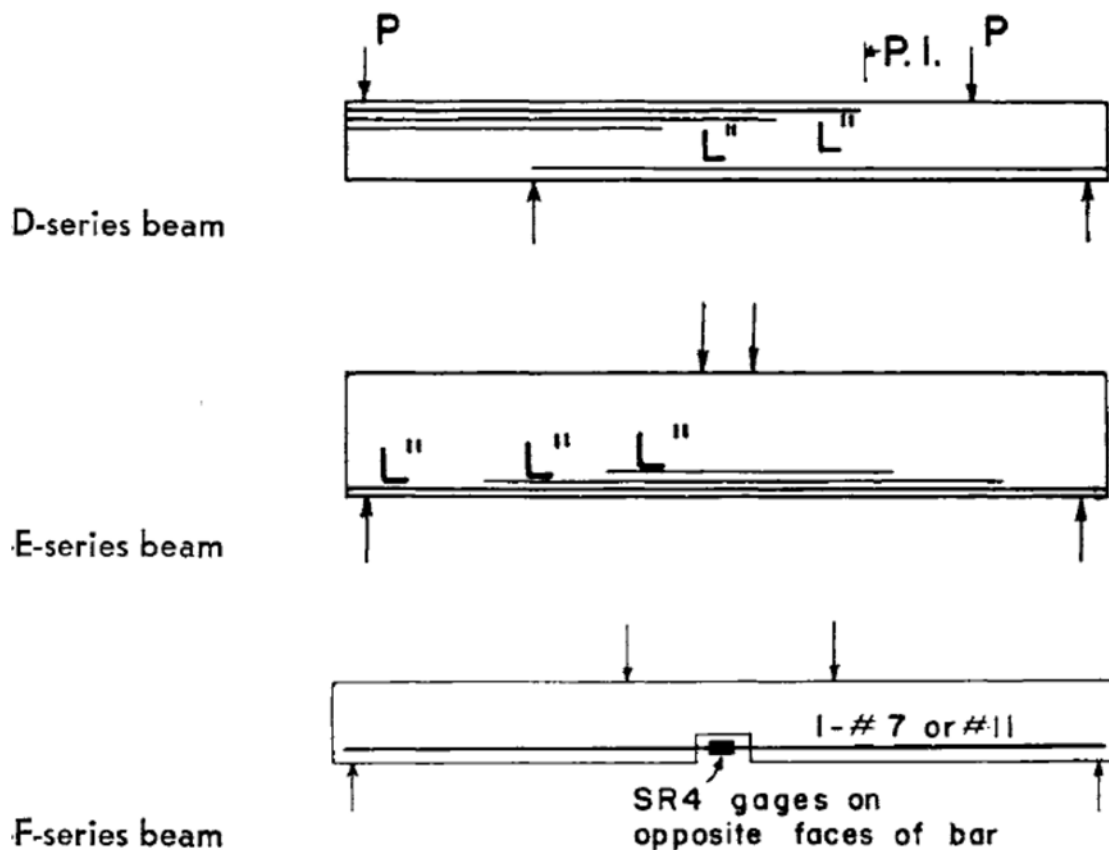

Figure 1.12 Beam test specimens (Ferguson and Thompson 1962)

5. Beam-column joint specimens: This category of specimen includes monolithic beam-column joints tested under cyclic loading, such as that shown in Figure 1.13. The behavior of the specimens is significantly affected by the bond between the bars and the concrete within the joint region. Examples of early studies using this type of specimens include those tested by Bertero and McClure (1964) and Hansen and Connor (1967). Liande and Jirsa (1982) provided a summary of previous studies and concluded that the loss of bond between concrete and beam bars in the joint may affect the stability of the whole structural system. Lee and Yu (2009) also tested exterior beam-column joints under cyclic loading with different anchorages methods in the joint region. Simulated beam-column joint specimens are not included in this category because that test specimen consists of a column with bars embedded in the column but no beam.

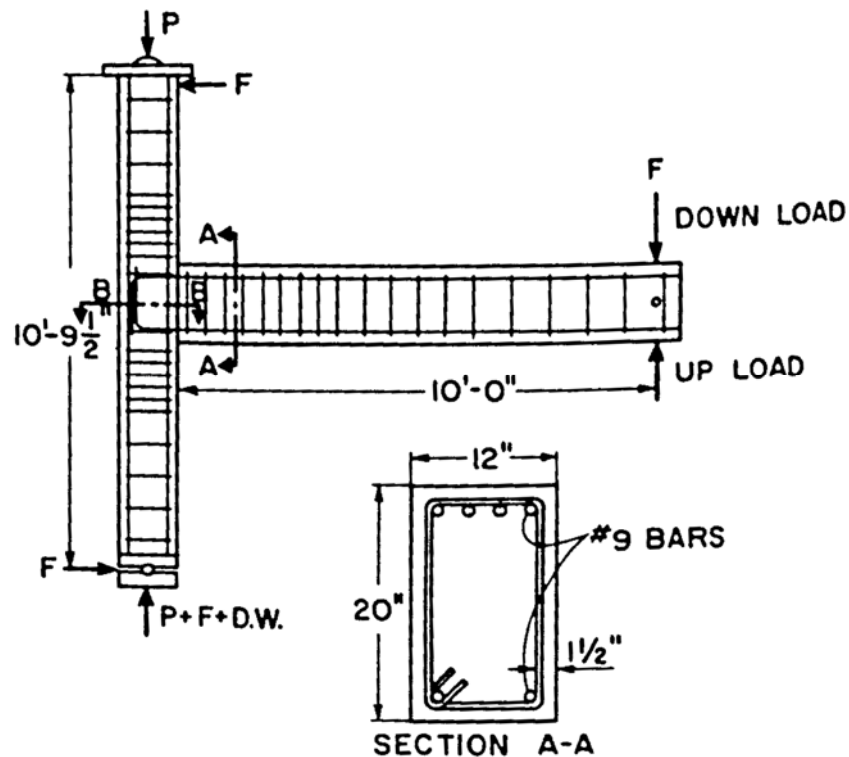

Figure 1.13 Beam-column specimen details (Hansen and Connor 1967)

1.3 PREVIOUS WORK

This section presents the results of previous studies, focusing on tests performed using specimens with deformed hooked bars subjected to monotonic loading. Studies with plain bars are excluded due to the differences in failure mechanism between deformed and plain bars, and the fact that plain bars are seldom used in modern construction. Cyclic or repeated loads are excluded as well due to the different nature of loading, which leads to different behavior for the member tested.

Menzel (1941, 1952) and Menzel and Wood (1952)

Menzel (1941) and Menzel (1952) used pullout specimens to study the effects of type of reinforcing bar (plain and deformed with different deformation configurations, square, and rounded bars), anchorage end (straight or hooked with a 180° hook), and the depth of concrete under the bar ($2\frac{1}{8}$, $5\frac{7}{8}$, $9\frac{1}{8}$, $15\frac{1}{8}$, or $33\frac{1}{8}$ in.). The latter study was to investigate the effect of the depth of fresh concrete under the bar. The greater the depth, the greater the potential for settlement cracking as the heavier constituents of concrete move (or settle) around fixed objects, such as reinforcing bars. The bar with typical cover (here, $2\frac{1}{8}$ in.), is described as a bottom bar, and the bars with the other depths are described as top bars. The hooks had a tail cover of 2 in. and an extension beyond the bent portion of $4d_b$. The concrete compressive strength was 3,600 psi. Menzel (1941, 1952) compared the load-slip behavior of the specimens with hooked bars with that of the specimens with straight bars and noted that top bars (regardless of whether the bars were straight or hooked) had significantly lower peak loads than the bottom bars. Menzel concluded that the shape of load-slip curves was influenced more significantly by the settlement of concrete

than by the nature of the anchorage end (straight or hooked), embedment length, or bar cross section (square or round).

Menzel and Woods (1952) primarily performed pullout tests and a few beam tests containing $\frac{3}{4}$ - and $\frac{7}{8}$ -in. diameter bars with different end anchorage configurations (straight or 180° hooked), various types of web reinforcement in the anchorage zone, and positions of the hook with respect to the center of the end support. Other factors not related to the scope of this study were investigated, including the effect of various amounts of entrained air in concrete on bond and the effect of prestressing plain bars anchored by heavy-end plates. Cracking patterns were reported for the beams and the effect of diagonal tension cracking on bond was investigated. In the study, diagonal tension cracks, in particular, were observed to reduce the effective embedded length and induce cracking in the concrete surrounding the bar, causing the bar to become less effective in limiting slip caused by beam action. They concluded that, although the use of hooks improved the strength of the beams with and without web reinforcement, a minimum amount of web reinforcement should be provided, and that hooked deformed bars developed higher anchorage capacity than hooked plain bars. Compared with straight bar anchorages, hooked bars helped to offset the anchorage loss effect resulting from concrete settlement. Menzel and Woods observed that there was less of a tendency to develop diagonal tension cracks in beams with hooked bars than in beams with straight bars. Regarding the location of a bottom hook with respect to the support, they observed that hooked bars that were located closest to the end of the beam had a higher anchorage capacity than hooked bars located 2 in. away from the center of the support, for configurations both with and without transverse reinforcement.

Mains (1951)

Mains (1951) tested 18 pullout and 40 beam specimens with $\frac{7}{8}$ -in. diameter bars to measure the distribution of bond stresses along the length of the bar, and to correlate the results of pullout tests with beam tests. Plain and deformed bars were used with straight and hooked ends. Prior to casting, the bars were sliced longitudinally into two unequal parts and strain gages were placed inside the bars at a spacing of 2 in. between them in a groove machined for that purpose. The two parts of the bars were welded back together, and the bars were ready to be used for the tests. Of the 58 specimens, three pullout specimens and three beam specimens contained hooked deformed bars. All specimens with deformed hooked bars failed due to fracture of the reinforcement. Mains observed that in pullout specimens containing deformed bars with hooks, the hook carried approximately one-quarter of the load at fracture, compared with approximately two-thirds of the load at fracture for hooks in plain bars, indicating that the effective bond along the deformed bar was greater than along the plain bar. His measurements showed that the straight portion of hooked deformed bars had greater bond strength than the straight portion of plain reinforcing bars. Based on bar strain measurements from beam specimens, Mains concluded that the value and distribution of both bond and steel stresses were governed by the location of cracks in the beam, and that plain hooked bars were anchored by the hook while deformed hooked bars developed considerable bond along the straight portion of the anchorage length. Mains concluded that the total shear and the local bond stress were not directly proportional. Although pullout and beam tests are different in nature, Mains stated that *“there is close correlation between the behavior of the portion of a beam bar between the free end and the nearest crack, and the portion of a pull-out bar between the free*

end and a point on the bar the same distance from the free end as the crack in the beam.” (Mains 1951).

Minor (1971), Minor and Jirsa (1975)

Minor (1971) and Minor and Jirsa (1975) tested 80 beam-end specimens to study the effects of geometric factors on the anchorage capacity of hooked bars. They used 37 different bar configurations, including three different bar sizes (No. 5, 7, and 9). The steel had yield strengths of 66,000 psi for No. 5 bars, 63,000 or 73,000 psi for No. 7 bars, and 44,000 or 65,000 psi for No. 9 bars. The bars had bend angles of 0°, 45°, 90°, 135°, and 180°, development length-to-bar diameter ratios (ℓ_{dh}/d_b) between 2.4 and 9.6, and inside radius-to-bar diameter (r/d_b) ratios between 1.6 and 4.6. The test specimens had a single reinforcing bar with no other reinforcement, except for a 10-gage wire single U-stirrup in one of the series placed to prevent damage to the testing apparatus. Bond breakers consisting of PVC tubes were placed from the lead end of the anchorage length to the surface of the specimen. Bonded lengths (measured from the start of the bend) of 1.5 to 6 in. were used for No. 5 bars, 4.3 to 8.5 in. for No. 7 bars, and 8.3 in. for No. 9 bars. Concrete compressive strengths ranged from 2,400 to 6,600 psi. Test results were reported in terms of measured load-slip curves.

Minor and Jirsa concluded that the anchorage strength of a hooked bar was similar to that of a straight bar of equal development length, with the exception of bars with very short anchorage lengths. The measured slip of hooked bars was larger than that of straight bars with equal anchorage length-to-bar diameter ratio, and both larger bend angles and smaller inside bend radii-to-bar diameter ratios resulted in greater bar slip for a given stress. Minor and Jirsa recommended using 90° hooks instead of 180° hooks, and making the inside radius of a hook as large as practical.

Marques (1972), Marques (1973), Marques and Jirsa (1975)

These studies used simulated beam-column joints containing two hooked bars per column. The effects of seven parameters on anchorage strength were studied: Hooked bar size (No. 7 and No. 11), hook geometry (90° and 180°), degree of confinement provided by the column longitudinal reinforcement, the presence of column ties through the joint region, the value of concrete side cover, lead embedment length (length from face of the column to the hook bend), and the column axial load. Marques (1972) tested 10 beam column joints with hook geometry conforming to the design provisions in the ACI 318-71 Building Code (ACI Committee 318 1971). Marques (1973) tested 18 beam column joints, with 12 specimens containing hooks conforming to the provisions in ACI 318-71 and 6 specimens with detailing that did not conform to the provisions in ACI 318-71. Marques and Jirsa (1975) analyzed the experimental results from the two previous studies, which had a combined total of 22 specimens conforming to the design provisions for hooked bar anchorages in ACI 318-71. Within that set, the axial load applied to the columns ranged from 140,000 to 550,000 lb, the concrete compressive strength of the specimens ranged from 3,600 to 5,100 psi, and the center-to-center spacing between hooked bars ranged from 4.84 to 8.13 in. To study the effect of the location of the beam bars (hooked bars) with respect to the column longitudinal bars on anchorage strength, the anchorage strength of hooked bars placed inside the column longitudinal bars was compared the strength of hooked bars placed outside the column bars, in both cases with 2⁷/₈ in. concrete cover on the hooked bar. To isolate the effect of confining transverse reinforcement, No. 3 ties were placed throughout the joint at a 5 in. or 2¹/₂ in. spacing, and the hooked bars were placed outside the column longitudinal bars. The concrete cover

on the hooked bars was $2\frac{7}{8}$ in. The effect of concrete cover was studied by placing the beam bars (hooked bars) outside the column bars and reducing the concrete cover to $1\frac{1}{2}$ in.

The axial compression force was applied to the column at the start of the test, and was held constant. After the axial load was applied, the hooked bars were loaded monotonically in tension until one of the hooks pulled out of the column. Marques reported that typical failures were sudden and brittle, and caused spalling of the entire side face of the column.

Marques and Jirsa concluded that variations in axial load had a negligible effect on the anchorage strength of hooked bars and that there were no significant differences in behavior between 90° and 180° hooked bars. Larger embedment lengths and the presence of closely spaced ties within the joint increased the anchorage capacity of hooked bars. Based on their results, Marques and Jirsa proposed the following design equation:

$$f_h = 700(1 - 0.3d_b)\psi\sqrt{f'_c} \quad (1.2)$$

where f_h is the tensile stress developed in a hooked bar in psi (but not greater than f_y), f'_c is the concrete compressive strength in psi, and d_b is the diameter of the hooked bar in in. The value of ψ proposed by Marques and Jirsa ranged from 1.0 to 1.8, depending on the amount of lateral reinforcement provided, side cover, and bar size. Marques and Jirsa proposed that if the anchorage stress developed by the hook is less than the yield stress of the bar, additional anchorage strength can be obtained from the straight lead embedment ℓ_l , between the bend in the hook and critical section. The additional strength can be calculated using Eq. (1.3).

$$\ell_l = \frac{0.04A_b(f_y - f_h)}{\sqrt{f'_c}} + \ell' \quad (1.3)$$

where ℓ' is the greater of $4d_b$ or 4 in.

The first term in Eq. (1.3) equals the length of straight bar needed to sustain a stress of $f_y - f_h$ in accordance with the design provisions for anchorage in ACI 318-71, where f_y is the yield strength of the hooked bar.

Pinc, Watkins, and Jirsa (1977)

Pinc et al. (1977) tested 16 simulated beam-column joint specimens similar to the specimens tested by Marques and Jirsa (1975) to investigate the effects of straight lead embedment and lightweight aggregate concrete on the strength of hooked bar anchorages. Eight specimens were cast using lightweight concrete and the other eight were cast using normalweight concrete. The specimens with normalweight concrete had two No. 9 or No. 11 hooked bars with a 90° bend angle and had no transverse reinforcement in the joint region. The lead embedment length ranged from 4³/₈ to 15 in., with a side cover of 2⁷/₈ in. for all specimens. Concrete compressive strengths ranged from 3,600 to 5,400 psi, and the average axial stress applied to the specimens ranged from 640 to 800 psi. Specimens with lightweight aggregate concrete had two No. 7 or No. 11 hooked bars. The hooks on seven of the specimens had a 90° bend angle and one had a 180° bend angle. Seven specimens had no transverse reinforcement in the joint region and one had No. 3 ties spaced at 5 in. in the joint region. Lead embedment lengths of 6 and 9¹/₂ in. were used for the No. 11 and No. 7 hooked bars, respectively. The side cover was 2⁷/₈ in. for all specimens. Concrete compressive strengths ranged from 4,200 to 5,600 psi, and the average axial stress applied to the specimens was 850 psi, with the exception of one specimen that was subjected to a 3,000 psi axial stress.

Pinc et al. (1977) concluded that the anchorage failure of the hooked bars was governed by the loss of the concrete side cover and that the main factors affecting the anchorage capacity were

the embedment length and the presence of transverse reinforcement. They also concluded that the use of lightweight concrete had a significant effect on the hooked bar anchorage strength. Based on their findings they proposed a basic equation to calculate embedment length that included modification factors for concrete cover and the effect of using lightweight aggregate concrete.

Jirsa, Lutz, and Gergely (1979)

Jirsa et al. (1979) developed new provisions for the design and detailing of hooked bar anchorages based on the test results of Marques and Jirsa (1975) and Pinc et al. (1977). Their recommendations introduced changes to the design provisions for standard hooks in ACI 318-77 (ACI Committee 318 1977). According to Jirsa et al. (1979), the development length provisions for hooked bars in ACI 318-77 resulted in development lengths that underestimated the length necessary to fully develop No. 3 to No. 8 bars, and overestimated the development length for bars greater than No. 8. Their proposal followed a simpler approach in which calculating the straight embedment length from the hook to the critical section was no longer needed, relying instead on the total development length. Jirsa et al. (1979) proposed that the embedment length be a linear function of the bar diameter, and they recommended that a ϕ -factor of 0.8 be directly introduced into the anchorage provisions.

Johnson and Jirsa (1981)

Johnson and Jirsa (1981) tested 36 wall specimens with 90° standard hooks to study the effects of spacing and short embedment on the anchorage strength of hooked bars in a thin wall. One-hook full-scale wall specimens contained either a No. 4, No. 7, No. 9, or No. 11 hooked bar, and three-hook wall specimens contained No. 7 or No. 11 hooked bars with a 11 or a 22 in. spacing between the hooks. The thickness of the walls ranged from 3.5 to 8.5 in. Minimum wall thickness

was established by adding 1.5 in. of concrete cover to the back of the standard hook. The distance between the bars and the region representing the compressive force was varied between 8 and 18 in. to investigate the effect of depth of the beam or slab framing into the wall on anchorage strength. Concrete compressive strength ranged from 2,400 to 5,450 psi. The amount of flexural reinforcement was proportioned to prevent flexural failure. Of the 36 wall specimens, 34 had no reinforcement in the hook region, while the other two had one No. 4 bar placed parallel to the horizontal reinforcement, in front of the hook at about mid height of the 90° bend.

Johnson and Jirsa observed that the controlling mode of failure for short embedded hooked bars was loss of cover in front of the hook instead of pullout or side splitting. The failure surface had a conical shape similar to that of headed studs or anchor bolts in tension tests. The anchorage capacity of short hooked bars in beam-wall specimens was found to be inversely proportional to beam or slab depth for the range of effective depths tested. Johnson and Jirsa observed that for a given embedment length, increasing the bar diameter resulted in a slight increase in the anchorage force the hook could carry. The anchorage strength of multiple-hook specimens was lower for specimens with closely spaced hooks, while specimens with large hook spacing had similar strength to that of specimens with a single hooked bar.

Soroushian, Obaseki, Nagi, and Rojas (1988)

Soroushian et al. (1988) tested seven simulated beam-column joint specimens with 90° standard hooks. One specimen had two No. 6 hooked bars, five specimens had two No. 8 hooked bars, and one specimen had two No. 10 hooked bars. Specimen dimensions were 14×12 in. with a side cover of 3½ in. and a tail cover of 2 in. Concrete compressive strength was 3,780 psi for six specimens and 6,050 psi for the other specimen. In six of the specimens, the amount of transverse

reinforcement in the joint was determined according to the requirements in the ACI 318-83 Building Code (ACI Committee 318 1983) for reinforced concrete frames in high seismic risk zones, while the remaining specimen had No. 3 ties at 4 in. within the joint region. Because the focus of the study was to measure the anchorage capacity of the hooks, a plastic tube was placed along the straight portion of the hooked bar to prevent bond between the straight portion of the bar and the concrete. Two supports were spaced at 11 in., and the specimens were positioned so that the hooked bars were positioned at the mid-span between the two supports.

Soroushian et al. (1988) concluded that the cracking pattern of all specimens was similar, and that as the ultimate load was approached, the specimens tended to expand normal to the plane of the hooks, resulting in concrete side cover spalling. The ultimate pullout force and the post-peak resistance increased as the spacing between the transverse hoops decreased and as the size of the transverse hoops increased. Soroushian et al. (1988) concluded that the hook pullout strength was larger if the joint was detailed according to the ACI 318-83 Building Code requirements for moment frames in high-risk seismic zones. For specimens with similar amounts of transverse reinforcement and concrete compressive strength, larger bar sizes had higher anchorage strength. Based on a single test, they concluded that hook anchorage strength is not improved by increasing the compressive strength of concrete, although they indicated that more test data were needed to adequately evaluate the effect of concrete compressive strength on hook anchorage strength.

Hamad, Jirsa, and D'Abreu de Paulo (1993)

Hamad et al. (1993) tested 24 simulated beam-column joints to investigate the effect of epoxy coating on the anchorage strength of hooked bars. Specimen configuration and test methodology were similar to those used by Marques and Jirsa (1975). Half of the specimens

contained epoxy-coated bars and the other half contained uncoated bars. The hooked bars were No. 7s and No. 11s, and had 90° or 180° bend angles. In two of the specimens, the hooks were placed outside the column longitudinal reinforcement (outside the column core) and the side cover was 1 $\frac{7}{8}$ in. In the remainder of the specimens the hooks were placed inside the column longitudinal reinforcement and the side cover was 2 $\frac{7}{8}$ in. All specimens had a tail cover of 2 in., and the concrete compressive strength ranged from 2,570 to 7,200 psi. Three different levels of transverse reinforcement were provided through the joint: no transverse reinforcement, No. 3 bars at 4 in., and No. 3 bars at 6 in. Two different column configurations were used. The first had a cross-section of 12×12 in. and contained four No. 8 longitudinal bars, while the second had a cross section of 12×15 in. and contained six No. 8 longitudinal bars. The depth of the simulated beams was 20 in. No axial load was applied to the columns.

Hamad et al. (1993) observed that epoxy-coated bars consistently developed lower anchorage strength than uncoated hooked bars. The specimen with No. 7 hooked bars placed outside the longitudinal bars with a side cover of 1 $\frac{7}{8}$ in. had a lower anchorage strength than the companion specimen with the hooked bars placed inside the longitudinal bars with a side cover of 2 $\frac{7}{8}$ in. Placing transverse reinforcement within the joint region increased the anchorage strength and the area under the load-slip curve. Hamad et al. recommended increasing the basic development length by 20% when using hooked epoxy-coated bars.

Joh, Goto and Shibata (1995), and Joh and Shibata (1996)

Joh et al. (1995) tested 19 simulated beam-column specimens containing four 19-mm ($\frac{3}{4}$ -in.) hooked bars and a 90° bend angle. One of the specimens had a two layers of hooked bars. Concrete compressive strengths ranged from 316 to 754 kgf/cm² (4,490 to 10,720 psi), and

concrete side cover ranged from 64.5 to 114 mm (2.5 to 4.5 in.). The confining transverse reinforcement used at the joint region consisted of two 6-mm (0.24-in.) ties spaced at 90 mm (3.54 in.), or four 6-mm (0.24-in.) ties spaced at 45 mm (1.77 in.). Two of the specimens were subjected to constant axial stresses of approximately one-third and one-sixth of concrete compressive strength (1,890 and 900 psi), respectively. Embedment lengths varied; one of the specimens had an embedment length of 80% of the column depth, another had an embedment length of 33% of the column depth, and the remaining specimens had an embedment length of half of the column depth. The hooks were loaded monotonically to failure, with the exception of one specimen which was subjected to a one-side load reversal.

Joh et al. (1995) classified modes of failure for 90° hooked bars embedded in beam-column joints into three types: (1) side split failure, where the side concrete cover spalls out, (2) local compression failure where a small region of concrete crushes inside the hook bend, and (3) rake-out failure where a concrete block is raked out towards the beam and all the bars fail at the same time. They concluded that for the range of concrete compressive strengths tested, anchorage strength was proportional to the square root of concrete compressive strength and to the reciprocal of the strut angle measured between the horizon and a straight line connecting the reaction point and the intersection of centerlines of the horizontal hooked bar and the hook tail. Additional strength was observed in specimens with transverse reinforcement that was proportional to the amount of transverse reinforcement at the joint region. Joh et al. (1995) proposed an equation to calculate the anchorage strength of hooked bars with rake-out failure.

Joh and Shibata (1996) tested 15 simulated beam-column joints specimens containing four 19 mm ($\frac{3}{4}$ in.) hooked bars and a 90° bend angle. Six were used to investigate the effect of side

cover, which ranged from 64.5 to 264.5 mm (2.54 to 10.4 in.). Concrete compressive strength for these specimens ranged from 238 to 355 kgf/cm² (3,380 to 5,040 psi). None of the specimens had an axial load applied to the column. The remaining eight specimens had a side cover of 64.5 mm (2.5 in.). The concrete compressive strengths for this set of specimens varied from 260 to 567 kgf/cm² (3,700 to 8,060 psi), and the axial stress ratio varied from 0 to 33% of concrete compressive strength. The columns had a depth of 400 mm (15.75 in.) and an embedment length equal to ½ of the column depth.

Joh and Shibata (1996) concluded that axial load had a significant effect on anchorage strength in columns with axial stresses up to 8% of the concrete compressive strength but had little effect once the axial stress exceeded 8% of the concrete compressive strength. They also found that effect of transverse reinforcement on anchorage strength decreased as the side cover increased, and that in specimens with large cover, front breakout failure cracks intersected the face of the column instead of the side of the column.

Joh, Goto, and Kitano (2001)

Joh et al. (2001) tested 7 simulated wall-beam joint specimens containing 90° hooked 19-mm (³/₄-in.) bars. Two threaded deformed hooked bars were used in each specimen. The specimens had a height of 2700 mm (106 in.), a width of 900 mm (35.4 in.), and a depth of and 250 mm (9.8 in.). Six specimens had an embedment length of 155 mm (6.1 in.) and one specimen had an embedment length of 83 mm (3.3 in.). In this study, embedment length was defined as the distance from critical section of the beam (face of the wall) to the *center* of the hook tail. Six of the specimens had a straight extension form the end of the bend to distance from the tip of the tail of 295 mm (11.6 in.), which complies with the provisions in ACI 318-14 (ACI Committee 318 2014)

for hook tail dimensions, and one specimen had an extension of 539 mm (21.2 in.). The center-to-center distance between the two hooked bars was 130 mm (5.1 in.). Concrete compressive strength ranged from 34.5 to 38.9 MPa (5,000 to 5,640 psi). Vertical wall reinforcement was placed in two layers with the bars spaced laterally at either 100 or 200 mm (3.9 or 7.9 in.). Tie bars parallel to the hooked bar were used in three specimens while the remaining four specimens did not contain any tie bars.

Joh et al. (2001) observed increases in anchorage capacity with increasing vertical wall reinforcement and horizontal wall reinforcement (in the form of ties). Horizontal wall ties were more effective than vertical wall reinforcement in increasing the hooked bar anchorage capacity, especially when they were spaced at 100 mm (3.94 in.). Joh et al. (2001) concluded that the addition of ties widened the stress transmission zone and, as a result, increased anchorage strength.

Ramirez and Russell (2008)

Ramirez and Russell (2008) tested 21 simulated beam-column joints containing 90° No. 6 and No. 11 hooked bars. Some bars were epoxy-coated and others were uncoated. The test apparatus was similar to that used by Marques and Jirsa (1975), except that the column did not have an axial load or top support, which allowed some of the columns to tilt during the test. Concrete compressive strengths ranged from 8,900 to 16,500 psi. Thirteen specimens contained no transverse reinforcement and the rest had ties spaced at 3 bar diameters. Concrete tail cover was $\frac{3}{4}$, $1\frac{3}{8}$, or $2\frac{1}{2}$ in., while all specimens had a clear side cover of $3\frac{1}{2}$ in. to the hooked bar.

Based on their test results and reviewing over 40 specimen tests in the literature, Ramirez and Russell (2008) recommended extending the design provisions for the anchorage of hooked bars in the ACI 318-05 Building Code (ACI Committee 318 2005) to include up to 15,000 psi

concrete without a limit on compressive strength compared to the upper limit of 10,000 psi that can be used in the ACI hooked bar development length equation. However, they recommended that transverse reinforcement spaced at three bar diameters should be provided for No. 11 bars anchored in concrete with compressive strengths above 10,000 psi to improve bond. Specimens with epoxy-coated bars had a lower anchorage strength than specimens with uncoated bars. They observed that providing a 2½-in. minimum cover at the end of the hook prevented kickout of the tail end of a hooked bar, but proposed that concrete tail cover could be reduced to the hooked bar diameter if transverse reinforcement was placed in the joint region with a spacing of three bar diameters or less. They recommended increasing the ACI 318-05 modification factor for side cover from 0.7 to 0.8, where the 0.7 factor is used to decrease the development length when a 2½-in. side cover and a 2-in. tail cover are provided for the hooked bar.

1.4 HIGH-STRENGTH CONCRETE (HSC)

In general, the term “high-strength concrete” (HSC) refers to concrete with compressive strength ranging from 8,000 to 20,000 psi or higher (Darwin et al. 2016). HSC can be achieved by decreasing the water-to-cementitious materials ratio, using high-range water-reducing admixtures, and using other additives, such fly ash and silica fume. Figure 1.14 illustrates stress-strain relationships for concretes with different compressive strengths. For normal strength concrete (NSC), the relationship between stress and strain is nearly linear up to 40 to 50% of the uniaxial compressive strength, while in HSC the relationship is close to linear up to 70 to 80% of the uniaxial concrete compressive strength. Figure 1.14 shows that the higher the strength, the higher the strain at maximum stress and the steeper post-peak slope and is, thus, more brittle than NSC (ACI Committee 363 1992, Mindess et al. 2003).

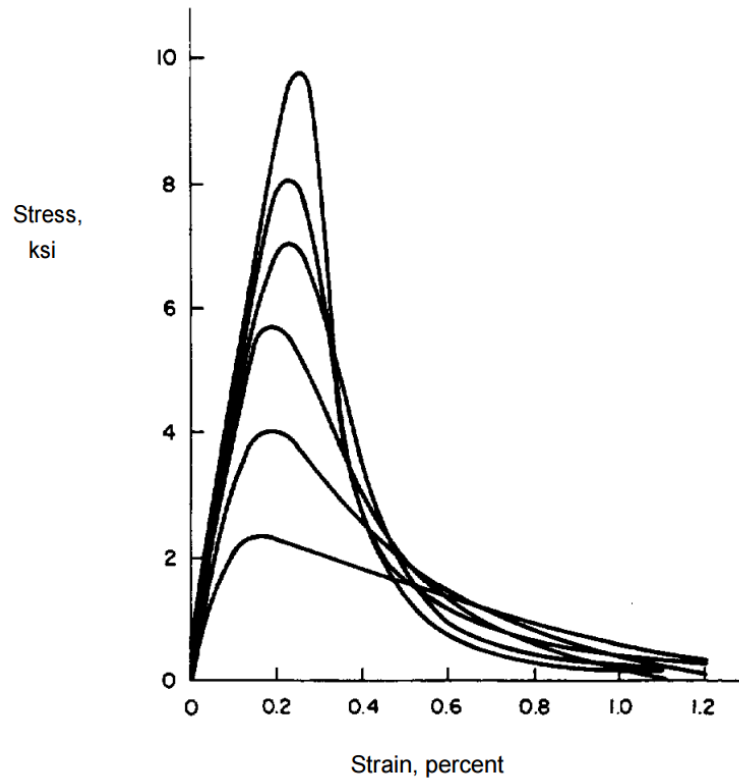

Figure 1.14 Complete stress-strain curves for concrete (ACI Committee 363 1992)

Using HSC in columns subjected to high axial loads will decrease the section dimensions required, reducing the dead load and allowing for more open space, particularly in the first floors of high-rise buildings. Because of this, the use of HSC is very important in reinforced concrete high-rise construction. Data on hooked bar anchorage capacity in high-strength concrete are limited, and therefore, this issue is addressed in more detail in this study.

1.5 HIGH-STRENGTH REINFORCING STEEL

The use of high-strength reinforcement can provide significant economic advantages in reinforced concrete members that require large amounts of reinforcing steel. Higher yield strength implies a reduction in reinforcing bar area, reducing congestion by increasing the spacing between bars. Reducing congestion has an important effect on labor costs, which can significantly outweigh

the material costs, because there are a smaller number of bars to be placed and field fabrication of less congested steel cages is faster and easier. There are other minor advantages such as easier concrete placement and the ability to use a wider range of mixture proportions. For most applications, the ACI 318-14 Building Code allows the use of reinforcing steel with a strength as high as 80,000 psi. This upper limit exists in part due to lack of information on the behavior of reinforced concrete members with high-strength steel reinforcement. Figure 1.15 presents typical stress-strain curves for reinforcing bars with different grades (Darwin et al. 2016). The figure shows that for some high-strength steels (with grades greater than grade 60), there is no defined yield plateau. This is in direct contrast with current design methods, a lot of which were based on assumption of elastic-perfectly plastic behavior and the strain in the steel not exceeding 0.0035 at the minimum specified yield strength.

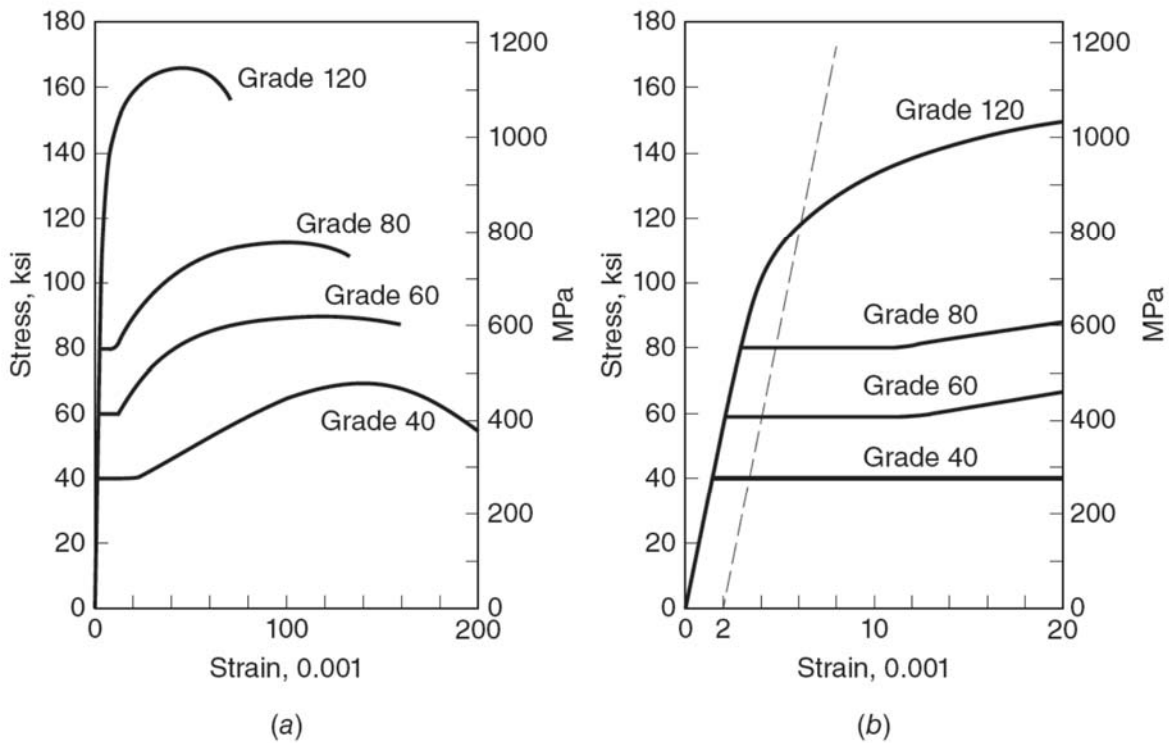

Figure 1.15 Typical stress-strain curves for reinforcing steel (Darwin et al. 2016)

1.6 OBJECTIVE AND SCOPE

Although some of the most important factors affecting the anchorage strength of hooked bars are recognized in previous studies (Jirsa et al. 1979, Marques and Jirsa 1975, Minor and Jirsa 1975, Pinc et al. 1977), the behavior of hooked bar anchorages is complex and is not similar to that of straight bar anchorages. Hooked bar anchorage strength is affected by embedment length, concrete compressive strength, concrete side cover, amount of transverse reinforcement in the beam-column joint region, hooked bar diameter (Marques and Jirsa 1975), type of concrete (normalweight or lightweight concrete) (Pinc et al. 1977), and the surface condition of the hooked bar (Hamad et al. 1993).

Embedment length has a significant effect on the anchorage strength of hooked bars, and increasing the embedment length causes the anchorage strength of the bar to increase up to yield. Keeping other factors the same, increasing concrete compressive strength will increase the anchorage capacity, but the current ACI 318-14 provision for hooked bars does not allow designers to take advantage of concrete strengths above 10,000 psi. Using transverse reinforcement increases the anchorage capacity of a hooked bar but the current provisions in ACI 318-14 recognize transverse reinforcement only if it consists of bars spaced at $3d_b$ or less through the joint region. In addition, confining transverse reinforcement oriented either vertically or horizontally is allowed to contribute to the capacity of 90° hooked bars, but only vertical confining reinforcement may be used to reduce the development length of 180° hooked bars. The current provisions for hooked bars allow a decrease of 30% in development length if a 2 in. tail cover and a $2\frac{1}{2}$ in. side cover are provided, a requirement that has not been extensively studied. Increasing number of hooked bars

per column may result in decreasing the anchorage capacity per hook, but this point has not been evaluated to any depth.

The number of specimens used to develop the development length provisions for hooked bars in ACI 318-14 includes just 38 specimens, 22 simulated beam-column joints tested by Marques and Jirsa (1975) and 16 simulated beam-column joints tested by (Pinc et al. (1977)) all with just two hooked bars per specimen. Concrete compressive strengths in these tests ranged from just 3,600 to 5,600 psi and the reinforcement was limited to Grade 60.

This study focuses on extending the design provisions for hooked bar development length so that they are applicable to a wider range of design parameters affecting anchorage strength. Results from past experiments on the performance of hooked bars at the University of Kansas were used by Sperry et al. (2015b) to determine the effects of embedment length (from 3.75 to 26 in.), bar size (No. 5, No. 8, and No. 11), concrete compressive strength (from 4,300 to 16,500 psi), concrete side cover (from 1.5 to 4 in.), amount and orientation of confining transverse reinforcement within the hook region (parallel or perpendicular to the hooked bar), and hook bend angle (90° and 180°). This study uses the results of 369 simulated beam-column joint tests to determine the effects on anchorage strength of the number of hooks per beam-column joint (two to four), center-to-center spacing between hooks (from $3d_b$ to $12d_b$), and hook placement (inside or outside the column core and extending the hooked bar halfway through the column depth or to the back of the column). The bar stresses at anchorage failure range from 22,800 to 141,600 psi. In addition to the beam-column joint specimens, the study uses results from 30 slab-to-wall specimens to check the effect of embedding hooked bars in members other than beam-column joints.

Test specimens consist of simulated beam-column joints, similar to those used by Marques and Jirsa (1975). Constant axial stress is applied to the specimens to simulate the condition of a column under compression. The study will include an analysis of the data to describe the effects of the key parameters on the behavior and anchorage strength of hooked bars, and to develop an equation that characterizes anchorage strength and propose development length design provisions for inclusion in ACI 318 and other design codes.

1.7 REFERENCES

Abrams, D. A., 1913, "Tests of Bond Between Concrete and Steel," Bulletin No. 71, Vol. XI, The University of Illinois, Urbana, 238 pp.

ACI Committee 318, 1971, "Building Code Requirements for Structural Concrete (ACI 318-71)" American Concrete Institute, Detroit, MI, 78 pp.

ACI Committee 318, 1977, "Building Code Requirements for Structural Concrete (ACI 318-77)" American Concrete Institute, Detroit, MI, 103 pp.

ACI Committee 318, 1983, "Building Code Requirements for Structural Concrete (ACI 318-83)," American Concrete Institute, Detroit, MI, 111 pp.

ACI Committee 318, 2005, "Building Code Requirements for Structural Concrete (ACI 318-05)," American Concrete Institute, Farmington Hills, MI, 430 pp.

ACI Committee 318, 2011, "Building Code Requirements for Structural Concrete (ACI 318-11) and Commentary (ACI 318R-11)," American Concrete Institute, Farmington Hills, MI, 505 pp.

ACI Committee 318, 2014, "Building Code Requirements for Structural Concrete (ACI 318-14)," American Concrete Institute, Farmington Hills, MI, 518 pp.

ACI Committee 363, 1992, "State-of-the-Art Report on High-Strength Concrete (ACI 363R-92)," American Concrete Institute, Farmington Hills, MI, 55 pp.

ACI Committee 408, 2003, "Bond and Development of Straight Reinforcing Bars in Tension (ACI 408-R-03)," American Concrete Institute, Farmington Hills, MI, 518 pp.

- Bertero, V. V. and McClure, G., 1964, "Behavior of Reinforced Concrete Frames Subjected to Repeated Reversible Loads," *ACI Journal, Proceedings*, Vol. 61, Oct., pp. 1305-1331.
- Darwin, D., Dolan, W. C., and Nilson, H. A., 2016, *Design of Concrete Structures*, 15th ed., New York: McGraw-Hill, 776 pp.
- Darwin, D., Tholen, M. L., Idun, E. K., and Zuo, J., 1996a, "Splice Strength of High Relative Rib Area Reinforcing Bars," *ACI Structural Journal*, Vol. 93, No. 1, Jan.-Feb., pp. 95-107.
- Ferguson, P. M. and Breen, J. E., 1965, "Lapped Splices for High-Strength Reinforcing Bars," *ACI Journal, Proceedings*, Vol. 62, No. 9, Sep., pp. 1063-1078.
- Ferguson, P. M. and Thompson, J. N., 1962, "Development Length of High Strength Reinforcing Bars in Bond," *ACI Journal, Proceedings*, Vol. 59, Jul., pp. 887-923.
- Fishburn, C. D., 1947, "Strength and Slip Under Load of Bent-Bar Anchorages and Straight Embedments in Haydite Concrete," *ACI Journal, Proceedings*, Vol. 44, Dec., pp. 289-305.
- Hamad, B. S., Jirsa, J. O., and d'Abreu d Paolo, N. I., 1993, "Anchorage Strength of Epoxy-Coated Hooked Bars," *ACI Structural Journal*, Vol. 90, No. 2, Mar.-Apr., pp. 210-217.
- Hansen, N. W. and Connor, H. W., 1967, "Seismic Resistance of Reinforced Concrete Beam-Column Joints," *Journal of the Structural Division, ASCE*, Vol. 93, No. ST 5, Oct., pp. 533-560.
- Hribar, J. A. and Vasko, R. C., 1969, "End Anchorage of High Strength Steel Reinforcing Bars," *ACI Journal, Proceedings*, Vol. 66, Nov., pp. 875-883.
- Jirsa, J. O., Lutz, L. A., and Gergely, P., 1979, "Rationale for Suggested Development, Splice, and Standard Hook Provisions for Deformed Bars in Tension," *Concrete International*, Vol. 1, No. 7, pp. 47-61.
- Jirsa, J. O. and Marques, J. L. G., 1972, "A Study of Hooked Bar Anchorages in Beam-Column Joints," University of Texas, Austin, TX, 92 pp.
- Joh, O., Goto, Y., and Kitano, A., 2001, *Anchorage Behavior of 90-degree Hooked Beam Bars in Reinforced Concrete Wall-Beam Intersections*. Paper presented at the International Symposium on Connections between Steel and Concrete, 10 pp.
- Joh, O., Goto, Y., and shibata, T., 1995, "Anchorage of Beam Bars with 90-deg Bend in Reinforced Concrete Beam-Column Joints," *Publication SP / ACI*, Vol. 157, pp. 97-116.
- Joh, O. and Shibata, T., 1996, *Anchorage Behavior of 90-Degree Hooked Beam Bars in Reinforced Concrete Beam-Column Joints*. Paper presented at the Eleventh World Conference on Earthquake Engineering WCEE, Paper No. 1196, 8 pp.

- Johnson, L. A. and Jirsa, J. O., 1981, "The Influence of Short Embedment and Close Spacing on the Strength of Hooked Bar Anchorages," No. 81-2, University of Texas, Structures Research Laboratory, Austin, TX, 93 pp.
- Lee, H.-J. and Yu, S.-Y., 2009, "Cyclic Response of Exterior Beam-Column Joints with Different Anchorage Methods," *ACI Structural Journal*, Vol. 106, No. 3, May-Jun., pp. 329-339.
- Liande, Z. and Jirsa, J. O., 1982, "A Study of Shear Behavior of Reinforced Concrete Beam-Column Joints," Phil M. Ferguson Structural Engineering Laboratory, University of Texas, Austin, TX, 118 pp.
- Mains, R. M., 1951, "Measurement of the Distribution of Tensile and Bond Stresses Along Reinforcing Bars," *ACI Journal, Proceedings*, Vol. 48, Nov., pp. 225-253.
- Marques, J. L. G., 1972, *A Study of Anchorage Capacities of Confined Bent-Bar Reinforcements*, Master Thesis, Rice University, Houston, TX, 57 pp.
- Marques, J. L. G., 1973, *A Study of Anchorage Capacities of Confined Bent-Bar Reinforcement*, Ph.D. Dissertation, Rice University, Houston, TX, 215 pp.
- Marques, J. L. G. and Jirsa, J. O., 1975, "A Study of Hooked Bar Anchorages in Beam-Column Joints," *ACI Journal, Proceedings*, Vol. 72, No. 5, May, pp. 198-209.
- Menzel, C. A. 1941. "A Proposed Standard Deformed Bar for Reinforcing Concrete," *A Compilation of Five Papers on Studies of Bond Between Concrete and Steel and Related Factors*, Chicago: Research and Development Laboratories of the Portland Cement Association.
- Menzel, C. A. 1952. "Effect of Settlement of Concrete on Results of Pull-Out Bond Tests," *A Compilation of Five Papers on Studies of Bond Between Concrete and Steel and Related Factors*, Chicago: Research and Development Laboratories of the Portland Cement Association.
- Menzel, C. A. and Woods, W. M. 1952. "An Investigation of Bond, Anchorage and Related Factors in Reinforced Concrete Beams," *A Compilation of Five Papers on Studies of Bond Between Concrete and Steel and Related Factors*, Chicago: Research and Development Laboratories of the Portland Cement Association.
- Mindess, S., Young, J. F., and Darwin, D., 2003, *Concrete*, Second Edition ed.: Pearson Education, Inc., 644 pp.
- Minor, J., 1971, *A Study of Bent Bar Anchorages in Concrete*, Ph.D. Dissertation, Rice University, Houston, TX, 135 pp.
- Minor, J. and Jirsa, J. O., 1975, "Behavior of Bent Bar Anchorages," *ACI Journal*, Vol. 72, No. 4, Apr., pp. 141-149.

Mylrea, T. D., 1928, "The Carrying Capacity of Semicircular Hooks," *ACI Journal, Proceedings*, Vol. 24, No. 2, pp. 240-263.

Pinc, R. L., Watkins, M. D., and Jirsa, J. O., 1977, "Strength of Hooked Bar Anchorages in Beam-Column Joints," 77-3, University of Texas, Austin, TX, 67 pp.

Podhorsky, N. L., 2011, *Evaluation of the orientation of 90° and 180° reinforcing bar hooks*, Master Thesis, Missouri University of Science and Technology, 174 pp.

Ramirez, J. A. and Russell, B. W., 2008, "Transfer, Development, and Splice Length for Strand/reinforcement in High-strength Concrete," Transportation Research Board, National Research Council, Washington, D.C., 99-120 pp.

Soroushian, P., Obaseki, K., Nagi, M., and Rojas, M., 1988, "Pullout Behavior of Hooked Bars in Exterior Beam-Column Connections," *ACI Structural Journal*, Vol. 85, No. 3, May-Jun., pp. 269-276.

Taub, J. and Neville, A. M., 1960, "Resistance to Shear of Reinforced Concrete Beams, Part-5- Anchorage and Bond," *ACI Journal, Proceedings*, Vol. 57, Dec., pp. 715-730.

Thompson, M. K., Jirsa, J. O., Breen, J. E., and Klinger, R. E., 2002, "Anchorage Behavior of Headed Reinforcement: Literature Review," University of Texas, Center for Transportation Research, Austin, TX, 116 pp.

Zuo, J. and Darwin, D., 2000, "Splice Strength of Conventional and High Relative Rib Area Bars in Normal and High-Strength Concrete," *ACI Structural Journal*, Vol. 97, No. 4, Jul.-Aug., pp. 630-641.

CHAPTER 2: EFFECT OF HOOKED BAR SPACING ON ANCHORAGE STRENGTH

2.1 INTRODUCTION

Hooked bars are often used to anchor reinforcing steel in exterior beam-column joints. The design provisions for hooked bars in the ACI Building Code (ACI 318-14) are based on the results of 38 tests of simulated beam-column joints by Marques and Jirsa (1975) and Pinc et al. (1977). Twenty-four additional tests by Hamad et al. (1993) were used to account for the effect of using epoxy-coated hooked bars. The test specimens in these studies contained two hooked bars. This contrasts with practice, where it is likely that members contain more than two bars – bars that may be separated by as little as one bar diameter.

The tests discussed in this chapter are part of a larger study that includes work reported by Searle et al. (2014) and Sperry et al (2015a, 2015b, 2017a, 2017b). Sperry et al. (2015b, 2017a, 2017b) evaluated tests of 245 simulated beam-column joint specimens with two hooked bars, 146 with confining reinforcement and 99 without, fabricated using normalweight concrete with compressive strengths ranging from 2,570 to 16,500 psi (17.7 to 114 MPa). Bar stresses at failure ranged from 30,800 to 143,900 psi (212 to 992 MPa). Sperry et al. (2015b, 2017a, 2017b) observed that for specimens containing two widely-spaced hooked bars, anchorage strengths calculated based on the provisions of ACI 318-14 overestimate anchorage strengths for larger hooked bars and overestimate the effects of concrete compressive strength and confining reinforcement. Rather than the square root of compressive strength, Sperry et al. observed that the effect of concrete compressive strength on the anchorage strength of hooked bars is proportional to the compressive strength raised to the 0.29 power. They also observed that the contribution to hooked bar anchorage strength of confining reinforcement oriented parallel to and located within 8 or 10 bar diameters (depending on bar size) of the straight portion of the bar for hooked bars with bend angles of 90

and 180° was proportional to the area of confining reinforcement and that the behavior and contribution to hooked bar anchorage strength of confining reinforcement oriented perpendicular to the straight portion of the hooked bar differed from that of reinforcement oriented parallel to the bar, with more legs of the confining reinforcement contributing but with each leg making a smaller contribution.

This chapter addresses the effects of the number and spacing of hooked bars in simulated beam-column joints on anchorage strength based on test specimens containing three or four closely-spaced hooked bars. The anchorage strengths from the current study are compared with anchorage strengths based on the best-fit equation by Sperry et al. (2015b, 2017b) describing the anchorage strength of simulated beam-column joints containing two hooked bars.

2.2 RESEARCH SIGNIFICANCE

The ACI 318-14 design provisions for the development of hooked bars are based on a limited number of tests using specimens containing only two hooked bars. The effects of additional hooked bars or close spacing between the hooked bars are not reflected in the current provisions. This study presents the first evaluation of the effect of bar spacing on the anchorage strength of hooked bars in beam-column joints. The study aims to expand the range of data and better understand the anchorage behavior of members containing more than two hooked bars and how the anchorage strength in these members is related to anchorage strength in members with two widely-spaced hooked bars with and without confining reinforcement.

2.3 EXPERIMENTAL PROGRAM

Sperry et al. (2015a, 2015b, 2017a, 2017b) described the behavior of simulated beam-column joints containing two hooked bars with center-to-center spacings ranging from 10 to 12

bar diameters (d_b). These specimens were used to develop a descriptive equation for hooked bar anchorage strength. This chapter includes the test results of 40 simulated beam-column joint specimens that contain 3 or 4 No. 5 (No. 16) or 3 No. 8 (No. 25) hooked bars with center-to-center spacing between the bars of $3d_b$, $4d_b$, $5d_b$, $5.5d_b$, or $6d_b$. Out of the 40 specimens, 15 had no confining reinforcement and 25 had either two No. 3 (No. 10) or five No. 3 (No. 10) hoops as confining reinforcement parallel to the straight portion of the hooked bar, the latter with a spacing of $3d_b$ – thus qualifying for the use of the 0.8 development length modification factor permitted in Section 25.4.3.2 of ACI 318-14. The concrete compressive strengths ranged from 4,490 to 11,460 psi (31 to 79 MPa), and hooked bar embedment lengths ranged from 5.2 to 16.1 in. (132 to 409 mm). Hooked bar stresses at failure ranged from 36,100 to 117,100 psi (249 to 808 MPa). The nominal side cover was $2\frac{1}{2}$ in. (65 mm), except for one specimen with a $3\frac{1}{2}$ in. (90 mm) side cover. This specimen is used in the comparison based on observations by Sperry et al. (2015b) showing no effect of cover on the anchorage strength of hooked bars with covers within the range $2\frac{1}{2}$ to $3\frac{1}{2}$ in. (65 to 90 mm). The effects of hooked bar size, number of hooked bars, center-to-center spacing, amount of confining reinforcement within the joint region, concrete compressive strength, and embedment length are investigated.

2.3.1 Test Specimens

The test specimens (Figure 2.1) were designed to simulate exterior beam-column joints. Column widths ranged from $10\frac{5}{8}$ to 17 in. (270 to 430 mm). The nominal tail cover was 2 in. (50 mm) for all specimens. Longitudinal and transverse reinforcement outside the joint region was selected to ensure adequate flexural and shear strength based on the assumption that all hooked bars would reach peak load simultaneously. The height of the column, $52\frac{3}{4}$ in. (1,340 mm), was

selected so that the support reactions would not interfere with the forces within the joint (Peckover and Darwin 2013).

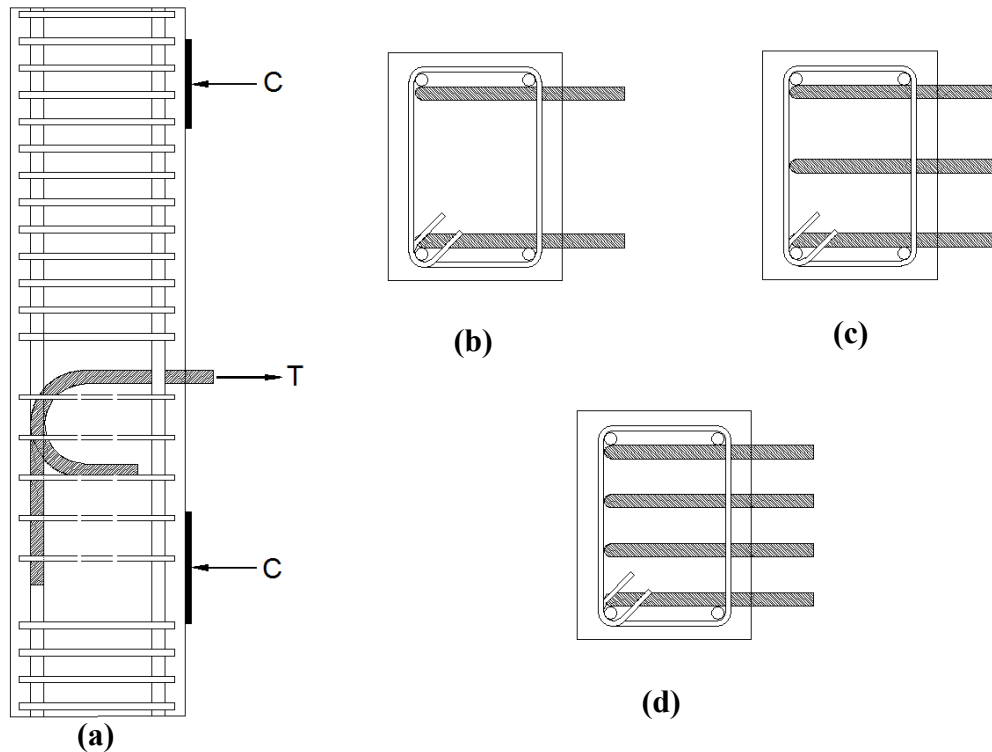
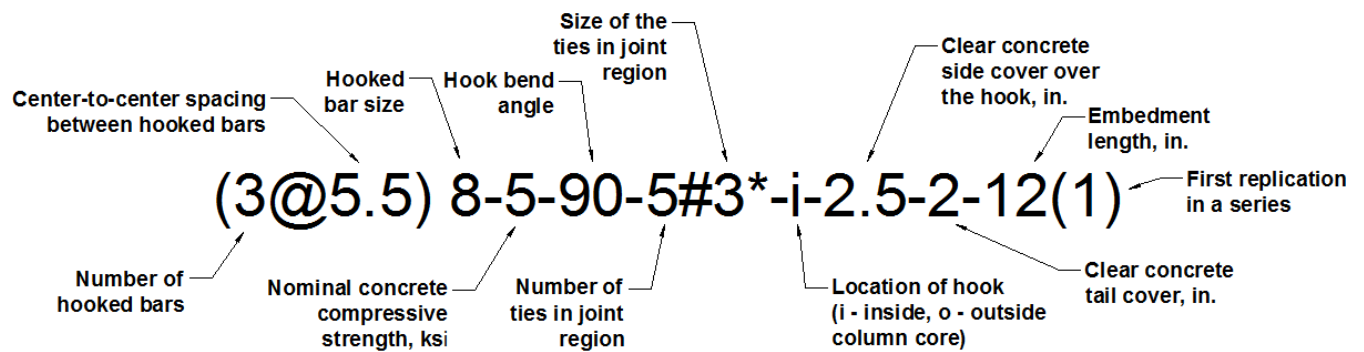

Figure 2.1 Schematic of test specimens (a) side view of specimen (b) cross-section of specimen with two hooks with confining reinforcement (c) cross-section of specimen with three hooks with confining reinforcement (d) cross-section of specimen with four hooks with confining reinforcement

Each specimen had a unique designation describing the key parameters. Figure 2.2 shows the convention used to identify specimens.



* For the vertical confining reinforcement, size of the ties in hook region is followed by 'vr', and its absence indicates that the horizontal confining reinforcement is provided.

Figure 2.2 Specimen designation

In this study, *embedment length* ℓ_{eh} refers to the distance measured from the column face to the back of the tail of the hook, in contrast to the *development length* ℓ_{dh} , which refers to the minimum embedment length required in Section 25.4.3 of ACI 318-14 to ensure that a bar can develop its yield strength. Embedment lengths ℓ_{eh} were chosen to ensure anchorage failure prior to bar yielding. In early tests, embedment lengths were equal to 80% of the development lengths defined in ACI 318-14, and later on, were calculated by extrapolating trends from test results.

Tables 2.1 and 2.2 show the specimen details, including hook bend angle; individual and average embedment lengths; measured concrete compressive strength; specimen width, clear side cover, clear tail cover, clear spacing between the hooked bars; number of hooked bars; center-to-center spacing between the hooked bars as function of bar diameter; average load at failure; and failure type (described under Test Results). A comprehensive description of all specimens used in this chapter is provided in Appendix A.

Table 2.1 includes 15 specimens without confining reinforcement: six specimens with three or four No. 5 (No. 16) hooked bars and nine specimens with three No. 8 (No. 25) hooked bars, where $\ell_{eh,avg}$ = average embedment length for the hooked bars (in.), f_{cm} = measured concrete compressive strength using 6×12 in. (150×300 mm) standard cylinders at the time of test (psi), b = width of the column (in.), c_{so} = clear concrete cover measured from the side of the column to the side of the hooked bar (in.), c_{th} = clear concrete cover measured from the column back to the hook tail (in.), c_h = clear spacing between hooked bars (in.), N_h = number of hooked bars loaded simultaneously, and T = average load on hooked bar at failure (lb).

Table 2.1 Test parameters for specimens with three or four closely-spaced hooked bars without confining reinforcement*

Specimen	Hook	l_{eh} in.	$l_{eh,avg}$ in.	f_{cm} psi	b^{**} in.	c_{so} in.	c_{th} in.	c_h in.	N_h	Center-to-center spacing/ d_b	T lb	Failure Mode
(4@4) 5-5-90-0-i-2.5-2-6 ¹	A	5.4	5.2	6430	13	2.4	2.8	1.9	4	3.87	14542	F
	B	5.3				4.9	2.9	1.9				F
	C	4.8				5.1	3.4	1.8				F
	D	5.3				2.8	2.9	-				F
(4@4) 5-5-90-0-i-2.5-2-10 ¹	A	9.0	9	6470	13	2.6	3.3	1.8	4	3.73	28402	F
	B	8.0				5	4.3	1.9				F
	C	9.3				5	3	1.6				F
	D	9.9				2.8	2.4	-				F
(4@4) 5-8-90-0-i-2.5-2-6 ¹	A	6.3	5.9	6950	13 $\frac{1}{8}$	2.5	1.8	1.9	4	4.00	15479	F/S
	B	5.8				5	2.3	1.6				F
	C	5.8				5	2.3	1.9				F
	D	6.0				2.5	2	-				F/S
(4@6) 5-8-90-0-i-2.5-2-6 ¹	A	6.0	5.9	6693	16 $\frac{7}{8}$	2.7	2	3.1	4	5.79	19303	F
	B	6.0				6.5	2	3.1				F
	C	5.8				6.5	2.3	3.1				F
	D	6.0				2.7	2	-				F/S
(3@4) 5-8-90-0-i-2.5-2-6 ¹	A	6.0	5.88	6950	10 $\frac{5}{8}$	2.6	2	1.8	3	3.80	16805	F
	B	5.6				5.6	2.4	1.9				F
	C	6.0				2.7	2	-				F
(3@6) 5-8-90-0-i-2.5-2-6 ¹	A	6.38	6	6950	13 $\frac{1}{8}$	2.6	1.6	3	3	5.80	24886	F
	B	5.88				6.2	2.1	3.1				F
	C	5.75				2.7	2.3	-				F/S
(3@5.5) 8-5-90-0-i-2.5-2-16 ²	A	16.5	16.1	6255	17	2.6	1.6	4.4	3	5.31	62798	F
	B	15.8				8	2.4	4.5				F
	C	16.0				2.8	2.1	-				F/S/TK
(3@5.5) 8-5-90-0-i-2.5-2-10 ²	A	9.0	9.4	6461	17	2.6	3.2	4.4	3	5.44	36054	F
	B	9.4				7.9	2.8	4.4				F
	C	9.8				2.5	2.4	-				F
(3@3) 8-5-90-0-i-2.5-2-10 ³	A	10.0	10.1	4490	12	2.6	2	2.4	3	2.94	28480	F
	B	10.3				5.5	1.8	2.3				F
	C	10.0				2.5	2	-				F
(3@5) 8-5-90-0-i-2.5-2-10 ³	A	10.3	10.1	4490	16	2.3	1.8	4	3	5.13	32300	F
	B	10.1				7.3	1.9	4.3				F
	C	10.0				2.5	2	-				F
(3@5.5) 8-8-90-0-i-2.5-2-8 ²	A	7.8	7.9	8700	17	3	2.4	4.3	3	5.12	37670	F
	B	8.8				8.2	1.4	3.4				F
	C	7.3				2.8	2.9	-				F
(3@3) 8-12-90-0-i-2.5-2-12 ^{3,4}	A	12.1	12.1	11040	12	2.5	1.8	2.1	3	3.03	48039	S
	B	12.1				5.4	1.9	2				F
	C	12.2				2.4	1.8	-				F
(3@4) 8-12-90-0-i-2.5-2-12 ^{3,4}	A	12.9	12.6	11440	14	2.5	1.3	2.9	3	4.00	55822	F/S
	B	12.5				6.4	1.6	3				F
	C	12.5				2.5	1.6	-				F/S
(3@5) 8-12-90-0-i-2.5-2-12 ^{3,4}	A	12.3	12.2	11460	16	2.4	1.8	4	3	5.06	52352	F
	B	12				7.4	2	4				F
	C	12.3				2.5	1.8	-				F
(3@5) 8-5-180-0-i-2.5-2-10 ^{3,3}	A	10	10	5260	16	2.5	2	4.3	3	5.25	45930	F
	B	10				7.8	2	4.3				F
	C	10				2.5	2	-				F

* All hooked bars had 90° hook bend angle except in specimen (3@5) 8-5-180-0-i-2.5-2-10, which had 180° bend angle

** Nominal depth of specimen is found by adding the nominal tail cover to the nominal embedment length.

‡ Specimen contained A1035 Grade 120 for column longitudinal steel

Hooked bar type: ¹ A1035, ² A1035^a, ³ A615, and ⁴ A1035^b as described in Table 2.4

Table 2.2 includes 25 specimens with confining reinforcement: 10 specimens with three or four No. 5 (No. 16) hooked bars and 15 specimens with three No. 8 (No. 25) hooked bars.

Table 2.2 Test parameters for specimens with three or four closely-spaced hooked bars with confining reinforcement*

Specimen	Hook	ℓ_{eh} in.	$\ell_{eh,avg}$ in.	f_{cm} psi	b^{**} in.	c_{so} in.	c_{th} in.	c_h in.	N_h	Center-to-center spacing/ d_b	T lb	Failure Mode
(4@4) 5-5-90-2#3-i-2.5-2-6 ¹	A	6.3	6.3	6430	13	2.5	1.9	1.9	4	3.93	21405	F
	B	6.1				5.0	2.0	1.9				F
	C	6.3				4.8	1.9	1.6				F
	D	6.4				2.5	1.8	-				F
(4@4) 5-5-90-2#3-i-2.5-2-8 ¹	A	8.4	8	6430	13	2.5	1.8	1.9	4	3.93	26017	F
	B	7.8				5.0	2.4	1.9				F
	C	8.0				4.9	2.1	1.8				F
	D	7.8				2.5	2.4	-				F
(3@6) 5-8-90-5#3-i-2.5-2-6.25 ¹	A	5.0	5.5	10110	13	2.5	3.8	2.9	3	5.9	25830	F
	B	6.3				5.4	2.6	3.0				F
	C	5.3				2.5	3.6	-				F
(3@4) 5-8-90-5#3-i-2.5-2-6 ^{‡1}	A	6.0	6.1	6703	10%	2.5	2.0	2.1	3	4.00	34889	F
	B	6.3				5.0	1.8	1.9				F
	C	6.0				2.5	2.0	-				F
(3@6) 5-8-90-5#3-i-2.5-2-6 ^{‡1}	A	6.0	6	6703	13½	2.5	2.0	3.4	3	6.00	36448	F
	B	6.0				5.0	2.0	3.1				F
	C	6.0				2.5	2.0	-				F
(4@4) 5-5-90-5#3-i-2.5-2-7 ¹	A	6.6	7.1	6430	13	2.5	2.5	1.5	4	4.00	27114	F
	B	7.9				4.6	1.3	2.0				F
	C	7.5				4.6	1.6	1.6				F
	D	6.5				2.4	2.6	-				F
(4@4) 5-5-90-5#3-i-2.5-2-6 ¹	A	6.0	6.3	6430	13	2.5	2.5	2.0	4	3.87	25898	F
	B	6.5				5.1	2.0	1.8				F
	C	6.6				5.0	1.9	1.8				F
	D	6.3				2.6	2.3	-				F
(4@6) 5-8-90-5#3-i-2.5-2-6 ^{‡1}	A	6.0	6	6693	16%	2.7	2.0	3.4	4	5.79	28321	F
	B	6.0				6.5	2.0	3.4				F
	C	6.0				6.5	2.0	3.1				F
	D	6.0				2.7	2.0	-				F
(4@4) 5-8-90-5#3-i-2.5-2-6 ^{‡1}	A	5.8	6	6703	13½	2.5	2.3	1.9	4	4.00	27493	F
	B	5.5				5.0	2.5	1.9				F
	C	6.3				5.0	1.8	1.9				F
	D	6.5				2.5	1.5	-				F
(3@6) 5-8-90-5#3-i-3.5-2-6.25 ¹	A	6.3	6.3	10110	15	3.5	2.1	2.6	3	5.69	35268	F
	B	6.3				6.6	2.1	3.3				F
	C	6.3				3.8	2.1	-				F
(3@5.5) 8-5-90-2#3-i-2.5-2-14 ²	A	14.6	14.4	6460	17	2.8	1.5	4.4	3	5.73	57261	F
	B	13.9				8.0	2.2	4.5				F
	C	14.8				2.5	1.3	-				F
(3@5.5) 8-5-90-2#3-i-2.5-2-8.5 ²	A	9.8	9.1	6460	17	2.5	0.9	4.3	3	5.50	40885	F
	B	8.8				7.8	1.9	4.3				F
	C	8.9				2.5	1.8	-				F
(3@5.5) 8-5-90-2#3-i-2.5-2-14(1) ⁴	A	14.7	14.9	5450	17	2.8	1.7	4.2	3	5.31	65336	F/TK
	B	15.2				7.9	1.2	4.3				F/TK
	C	14.8				2.6	1.6	-				F/TK

* All hooked bars had 90° hook bend angle

** Nominal depth of specimen is found by adding the nominal tail cover to the nominal embedment length.

‡ Specimen contained A1035 Grade 120 for column longitudinal steel

Hooked bar type: ¹ A1035, ² A1035^a, ³ A615, and ⁴ A1035^b as described in Table 2.4

Table 2.2 Cont. Test parameters for specimens with three or four closely-spaced hooked bars with confining reinforcement*

Specimen	Hook	ℓ_{eh} in.	$\ell_{eh,avg}$ in.	f_{cm} psi	b^{**} in.	c_{so} in.	c_{th} in.	c_h in.	N_h	Center-to-center spacing/ d_b	T lb	Failure Mode
(3@5.5) 8-5-90-2#3-i-2.5-2-8.5(1) ⁴	A	7.3	8.2	5450	17	2.3	3.5	4.5	3	5.53	32368	F
	B	8.9				7.9	1.8	4.3				F
	C	8.4				2.6	2.3	-				F
(3@3) 8-5-90-2#3-i-2.5-2-10 ³	A	9.9	10	4760	12	2.6	2.1	2.0	3	2.94	40721	F
	B	10.1				5.6	1.9	2.0				F
	C	10.0				2.5	2.0	-				F
(3@5) 8-5-90-2#3-i-2.5-2-10 ³	A	10.5	10.5	4760	16	2.5	1.5	4.5	3	4.88	44668	F
	B	10.6				8.0	1.4	3.9				F
	C	10.4				2.8	1.6	-				F
(3@5.5) 8-5-90-5#3-i-2.5-2-8 ²	A	8.0	8	6620	17	2.5	2.2	4.1	3	5.50	37126	F
	B	8.1				7.6	2.1	4.5				F
	C	7.8				2.5	2.4	-				F
(3@5.5) 8-5-90-5#3-i-2.5-2-12 ²	A	12.4	12.2	6620	17	2.5	1.8	4.3	3	5.50	66094	F
	B	12.1				7.8	2.1	4.5				F
	C	12.1				2.5	2.1	-				F
(3@5.5) 8-5-90-5#3-i-2.5-2-8(1) ⁴	A	7.3	7.6	5660	17	2.9	2.9	3.8	3	5.12	31369	F
	B	8.4				7.6	1.8	4.1				F
	C	7.3				2.9	2.9	-				F
(3@5.5) 8-5-90-5#3-i-2.5-2-12(1) ⁴	A	11.4	12	5660	17	2.5	2.8	4.3	3	5.44	47851	F
	B	12.5				7.8	1.7	4.5				F
	C	12.0				2.6	2.2	-				F
(3@3) 8-5-90-5#3-i-2.5-2-10 ^{†3}	A	10.0	9.9	4810	12	2.8	2.0	2.1	3	2.88	47276	F
	B	9.8				5.9	2.3	2.1				F
	C	9.9				2.3	2.1	-				F
(3@5) 8-5-90-5#3-i-2.5-2-10 ^{†3}	A	10.0	9.9	4850	16	2.5	2.0	4.0	3	4.88	61305	F
	B	10.0				7.5	2.0	4.0				F
	C	9.8				2.8	2.3	-				F
(3@3) 8-12-90-5#3-i-2.5-2-12 ^{‡4}	A	11.9	11.8	11040	12	2.5	2.3	2.0	3	3.00	62206	F
	B	11.9				5.5	2.3	2.0				F
	C	11.6				2.5	2.5	-				F
(3@4) 8-12-90-5#3-i-2.5-2-12 ^{‡4}	A	12.5	12.3	11440	14	2.5	1.8	2.8	3	4.00	64940	F
	B	12.0				6.3	2.3	3.0				F
	C	12.5				2.5	1.8	-				F
(3@5) 8-12-90-5#3-i-2.5-2-12 ^{‡4}	A	11.9	12.2	11460	16	2.5	2.2	4.0	3	5.00	64761	F
	B	12.4				7.5	1.7	4.0				F
	C	12.3				2.5	1.8	-				F

* All hooked bars had 90° hook bend angle

** Nominal depth of specimen is found by adding the nominal tail cover to the nominal embedment length.

‡ Specimen contained A1035 Grade 120 for column longitudinal steel

Hooked bar type: ¹ A1035, ² A1035^a, ³ A615, and ⁴ A1035^b as described in Table 2.4

2.3.2 Material Properties

Normalweight concrete with nominal compressive strengths of 5,000, 8,000, and 12,000 psi (34, 55, and 83 MPa) was used for the specimens. Actual compressive strengths ranged from 4,490 to 11,460 psi (31 to 79 MPa). The concrete contained Type I/II portland cement, crushed limestone

coarse aggregate with a maximum size of $\frac{3}{4}$ in. (19 mm), and Kansas River sand. Pea gravel was used in the 12,000-psi (83-MPa) concrete to improve workability. Two kinds of polycarboxylate based high-range water-reducing admixture were used: ADVA 140 was used in the 5,000 and 8,000 psi (34 and 55 MPa) concrete, and ADVA 575 was used in the 12,000 psi (83 MPa) concrete. Compared to ADVA 140, ADVA 575 has a lower addition rate and helps to achieve higher early concrete compressive strength. Both admixtures meet the requirements of ASTM C494 as type A and F, and ASTM C1017 type I plasticizing. Mixture proportions are listed in Table 2.3.

Table 2.3 Concrete mixture proportions

Material	Quantity (SSD)		
	5,000 psi	8,000 psi	12,000 psi
Type I/II Cement, lb/yd ³	600	700	750
Water, lb/yd ³	263	225	217
Kansas River Sand ¹ , lb/yd ³	1,396	1,375	1,050
Pea Gravel ² , lb/yd ³	-	-	316
Crushed Limestone ³ , lb/yd ³	1,734	1,683	1,796
Estimated Air Content, %	1	1	1
High-Range Water-Reducer, oz (US)	30 ⁴	171 ⁴	104 ⁵
<i>w/cm</i> ratio	0.44	0.32	0.29

Bulk specific gravity (saturated surface dry) =¹2.63, ²2.59, and ³2.60

⁴ ADVA 140. ⁵ADVA 575

Note: 1 ksi = 6.89 MPa, 1 oz = 29.57 ml, and 1 lb/yd³ = 0.593 kg/m³

No. 5 and 8 (No. 16 and 25) hooked bars were used in the study. Most hooked bars were fabricated from ASTM A1035 Grade 120 (830 MPa) reinforcement, with the exception that some No. 8 (No. 25) hooked bars were fabricated from ASTM A615 Grade 80 (550 MPa) reinforcement. ASTM A615 Grade 60 (420 MPa) reinforcing bars were used as confining steel in all specimens and as longitudinal reinforcement in most specimens. For some specimens where the flexural demand on the column was high, ASTM A1035 Grade 120 (830 MPa) bars were used to keep the column longitudinal reinforcement ratio to a reasonable value. Specimens with Grade 80 (550

MPa) hooked bars or Grade 120 (830 MPa) column longitudinal bars are indicated in Tables 2.1 and 2.2. Yield strength, tensile strength, nominal diameter, deformation dimensions and spacing, and relative rib area for the deformed steel bars used as hooked bars are presented in Table 2.4.

Table 2.4 Hooked bar properties

Bar Size	ASTM Designation	Yield Strength (ksi) ¹	Tensile Strength (ksi) ¹	Nominal Diameter (in.)	Average Rib Spacing (in.)	Average Rib Height		Gap Width		Relative Rib Area ³
						A ² (in.)	B ³ (in.)	Side 1 (in.)	Side 2 (in.)	
5	A1035	128	160	0.625	0.391	0.038	0.034	0.200	0.175	0.073
8	A615	76	95	1	0.666	0.059	0.056	0.146	0.155	0.073
8	A1035 ^a	135	168	1	0.574	0.057	0.052	0.16	0.157	0.078
8	A1035 ^b	129	168	1	0.666	0.056	0.059	0.146	0.155	0.073

¹ From mill test report ² Per ASTM A615, A706. ³ Per ACI 408R-3

^a Heat 2, ^b Heat 3, 1 in. = 25.4 mm, 1 ksi = 6.89 MPa

2.3.3 Loading System and Test Procedure

Figure 2.3 shows the test frame used in this study. The test frame is a modified version of the frame used by Marques and Jirsa (1975) and applies tensile forces to the hooked bars and a compression reaction from the bearing member simulating the action of a reinforced concrete beam on the joint. The upper compression member prevents the column from overturning and is placed so as to not interfere with the hook region. The flange widths for the upper compression member and the bearing member were 6⁵/₈ in. (168 mm) and 8³/₈ in. (213 mm), respectively. The locations of the reaction forces for the different size hooked bars, measured from the center of the hooked bar, are shown in Table 2.5.

Axial compressive loads were applied to more accurately simulate column loading conditions. In this study, a constant axial force of 30,000 lb (133,447 N) was applied to the specimens producing axial stresses of 95 to 360 psi (0.66 to 2.48 MPa). Marques and Jirsa (1975) found that differences in axial stress up to 3,000 psi (21 MPa) did not affect the anchorage strength

of the hooked bars; thus, the effect of different values of axial stress was not examined in this study.

The test frame was designed to accommodate two, three, or four hooked bars. Steel channel sections were used as a spreader beam between the load cells and the hydraulic jacks to engage the hooked bars (Figure 2.3). A detailed description of the test apparatus is provided by Peckover and Darwin (2013).

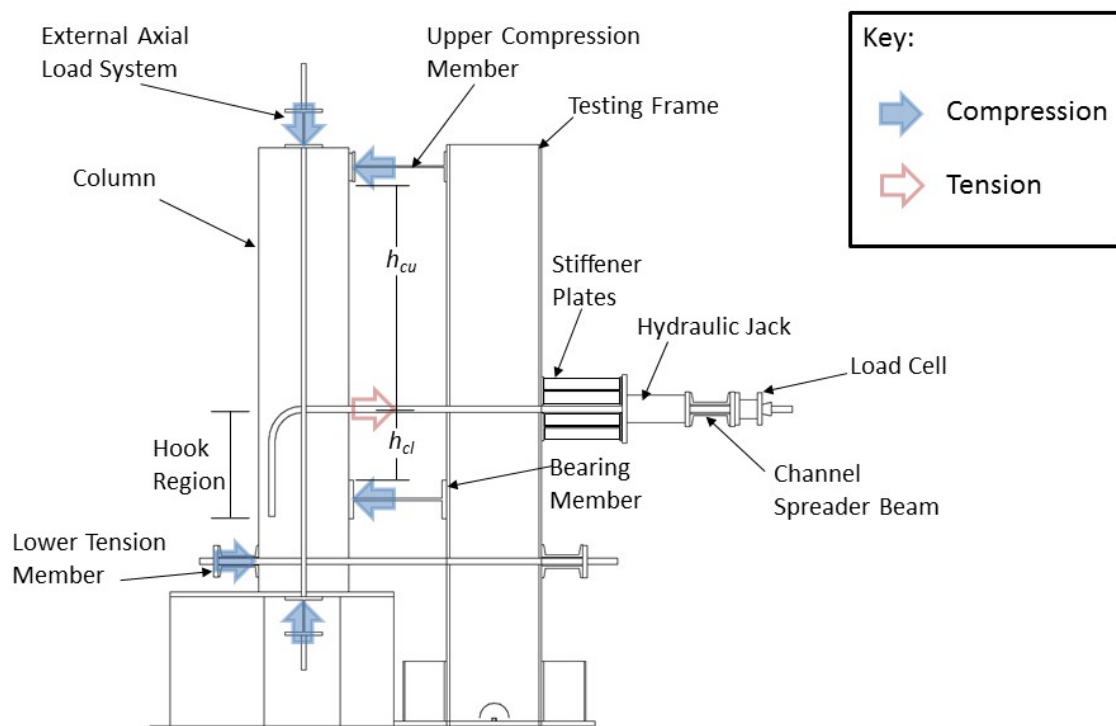

Figure 2.3 Test frame

Table 2.5 Location of reaction forces

	Size of Hooked Bar	
	No. 5 Hook	No. 8 Hook
Specimen Height, (in.)	52 ³ / ₄	52 ³ / ₄
Distance from Center of Hook to Top of Bearing Member Flange, h_{ct} (in.)¹	5 ¹ / ₄	10
Distance from Center of Hook to Bottom of Upper Compression Member Flange, h_{cu} (in.)¹	18 ¹ / ₂	18 ¹ / ₂

¹See Figure 2.3
1 in. = 25.4 mm

Hydraulic jacks were used to apply a tensile force to the hooked bars, simulating tensile forces in beam negative reinforcement. The tensile load was applied monotonically in steps of 5,000 or 10,000 lb (22,240 to 44,480 N) depending on the specimen size. Loading was paused after each step to allow cracks to be marked. The force on each hooked bar was measured using load cells, with the exception of early tests of specimens with more than two hooked bars where two load cells were used on the jacks and the force was distributed using a spreader steel beam. In all cases, the anchorage strength of the hooked bars was taken as the average force per hooked bar corresponding to the maximum total force during the test. The maximum force for each hooked bar was also recorded, although this did not, in general, coincide with the maximum total force on the system.

2.4 TEST RESULTS AND DISCUSSION

2.4.1 Failure Modes

Anchorage strengths and failure modes are presented in Tables 2.1 and 2.2. Three failure modes were observed for beam-column joint specimens in this portion of the study: front failure (F), in which a mass of concrete is pulled with the hooked bars from the front of the face of the column; side failure (S), in which the side face of the column splits off after vertical cracks form in the plane of a hook; and tail kickout (TK), where the tail of a 90° hook pushes the concrete cover off of the back of the column. Tail kickout was observed to occur following front or side failures and did not appear to affect anchorage strength, as will be shown in Chapter 3. The failure modes are shown in Figure 2.4.

Sperry et al. (2015a, 2015b, 2017a) found that the majority of the specimens containing two hooked bars experienced a combination of more than one failure mode with front failure

predominating. For specimens in the current study containing three or four hooks, however, all but three specimens exhibited only front failure: Two out of the 40 specimens exhibited combined F/S—one specimen contained four No. 5 (No. 16) hooked bars and the other contained three No. 8 (No. 25) hooked bars. Both specimens had 2½-in. (65-mm) side cover and no confining reinforcement within the joint region. One specimen with three No. 8 (No. 25) hooked bars, two No. 3 (No. 10) hoops as confining reinforcement at the joint region, and an average tail cover of 1½ in. (38 mm) exhibited a combined F/TK failure.

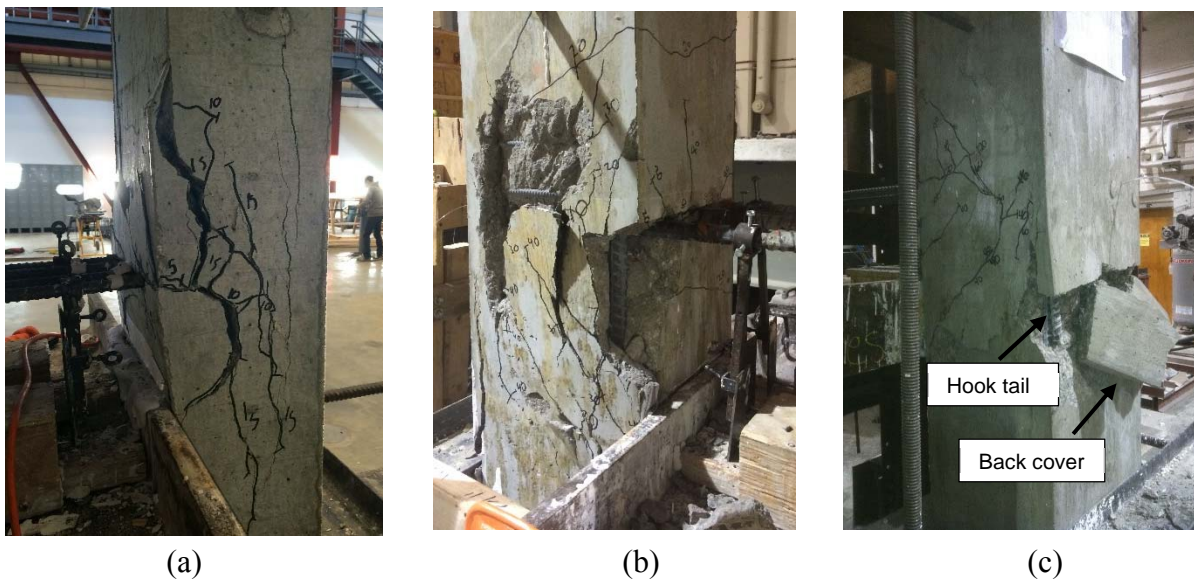

Figure 2.4 Failure modes (a) Front (F) (b) front (F) with side (S), and (c) Tail Kickout (TK)

2.4.2 Effect of Hooked Bar Spacing

The 40 specimens analyzed in this chapter were tested in different series, with different concrete compressive strengths at the time of testing. To allow comparisons be made between these specimens, the bar force at failure T is normalized to T_N with respect to a reference concrete compressive strength of 5,000 psi (34 MPa). This normalization is accomplished by multiplying T by $(5000/f_{cm})^{0.29}$ to obtain T_N , based on the observations by Sperry et al. (2015b, 2017b). The

joint shear at failure for the 40 specimens ranged from 4 to $10\sqrt{f_{cm}}$, with majority of the values below $6\sqrt{f_{cm}}$. Figures 2.5a and b show the normalized hooked bar force T_N for 12 specimens without confining reinforcement containing three or four closely-spaced hooked bars as a function of, respectively, the center-to-center bar spacing, expressed in multiples of the bar diameter d_b , and column width. Specimens in three groups are compared: (1) three specimens containing three No. 8 (No. 25) hooked bars with a nominal embedment length of 12 in. (300 mm) and column widths ranging from 12 to 16 in. (300 to 400 mm); (2) four specimens containing three No. 8 (No. 25) hooked bars with a nominal embedment length of 10 in. (254 mm) and column widths ranging from 12 to 17 in. (300 to 425 mm); and (3) five specimens containing three or four No. 5 (No. 16) hooked bars with a nominal embedment length of 6 in. (150 mm) and column widths ranging from $10\frac{5}{8}$ to $16\frac{7}{8}$ in. (266 to 422 mm). The specimens in each group above contained hooked bars with the same nominal embedment length but had different column widths. The two figures show that the forces in the hooked bars increased as the center-to-center spacing between the hooked bars and the specimen width increased. For the No. 5 (No. 16) bars, the only case in which specimens with a single bar size include results for both three and four hooked bars, Figures 2.5a and b indicate that using the center-to-center spacing provides a better correlation with anchorage strength than column width.

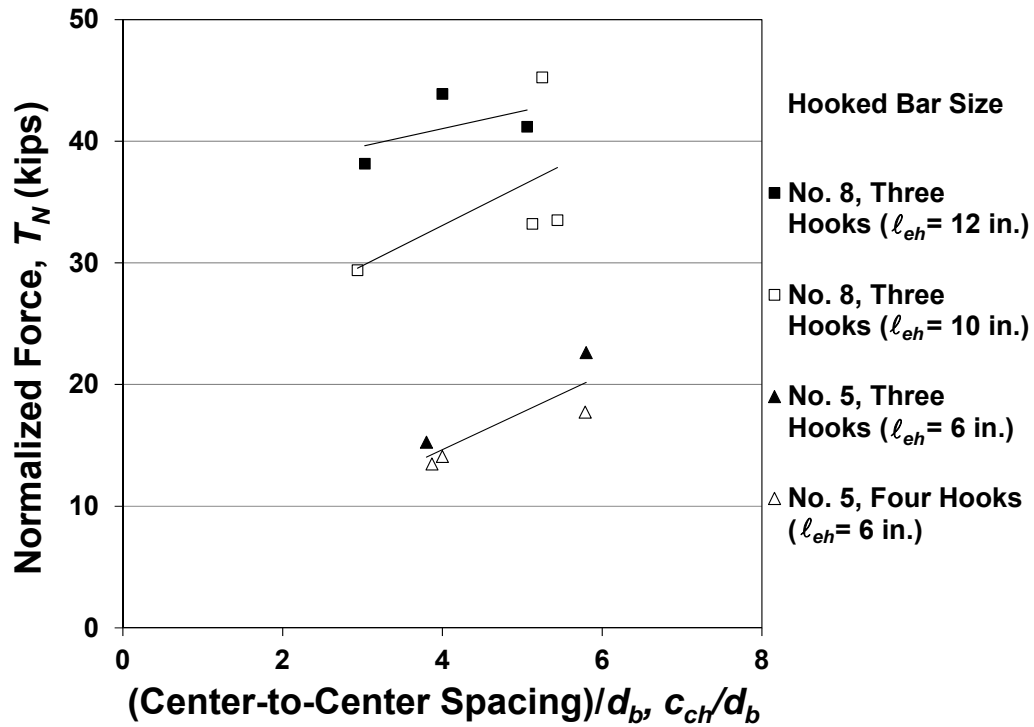

Figure 2.5a Normalized anchorage force per bar at failure T_N versus center-to-center spacing of hooked bars without confining reinforcement

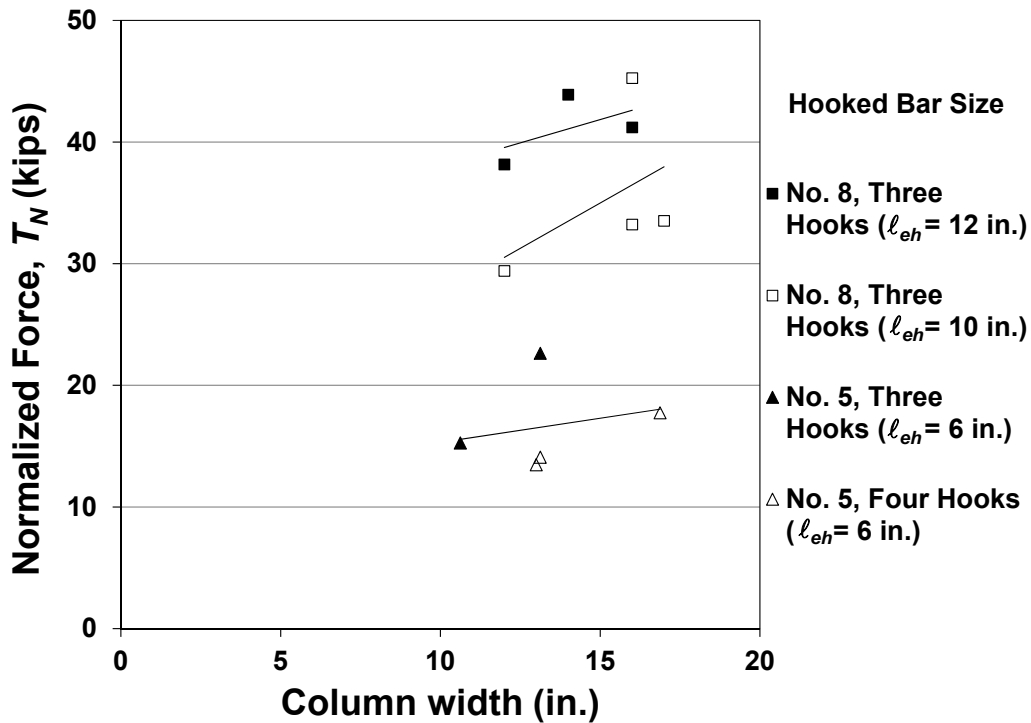

Figure 2.5b Normalized anchorage force per bar at failure T_N versus column width of hooked bars without confining reinforcement

Figure 2.6 compares the normalized anchorage force per bar at failure T_N to the center-to-center hooked bar spacing for specimens with five No. 3 (No. 10) hoops as confining reinforcement in the joint region. Two groups are compared, one with five specimens containing three No. 8 (No. 25) hooked bars with a nominal embedment length of 12 in. (300 mm) and nominal column widths ranging from 12 to 17 in. (300 to 425 mm); and one with five specimens containing three or four No. 5 (No. 16) hooked bars with a nominal embedment length of 6 in. (150 mm) and nominal column widths ranging from 10⁵/₈ to 16⁷/₈ in. (266 to 422 mm). Each group had specimens with the same embedment length but with different center-to-center spacing between hooked bars. The hooked bars in both groups exhibited an increase in the anchorage strength per hooked bar as the center-to-center spacing increased. The best-fit lines for the two groups are parallel. The slope of the lines is lower than those of the specimens without confining reinforcement (Figure 2.5a) suggesting that the detrimental effect of close spacing is reduced in the presence of confining reinforcement.

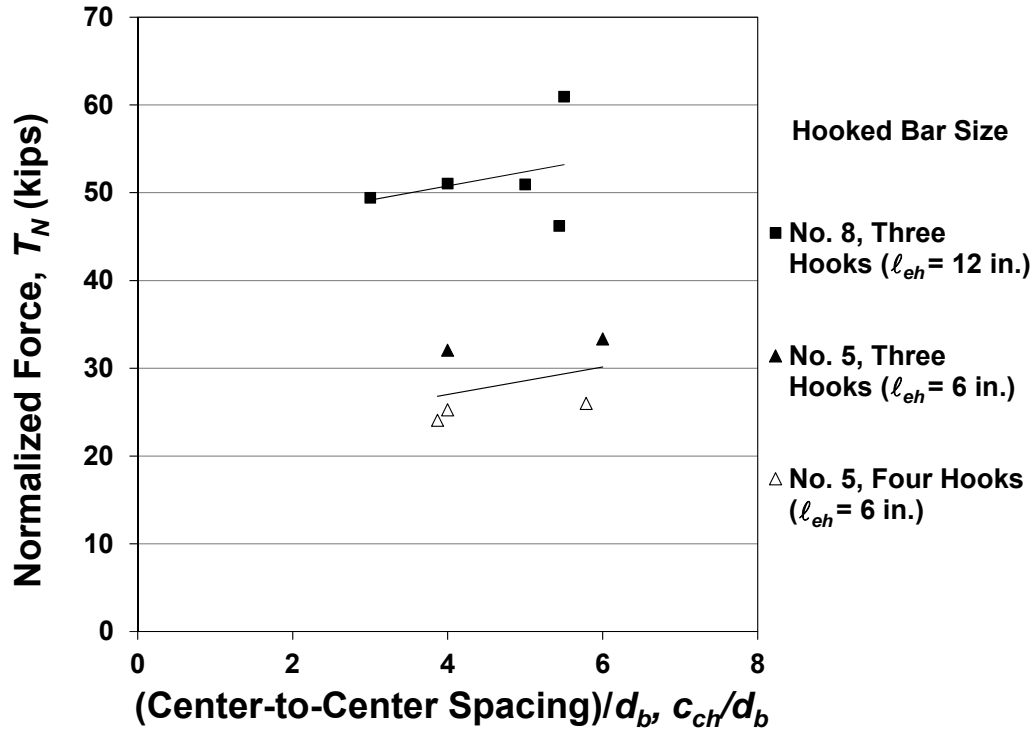

Figure 2.6 Normalized anchorage force per bar at failure T_N versus center-to-center spacing for hooked bars with five No. 3 (No. 10) hoops as confining reinforcement

2.4.3 Comparison with Descriptive Equations Proposed by Sperry et al. (2015b, 2017b)

Sperry et al. (2015b, 2017b) proposed a descriptive equation for the anchorage strength of two hooked bars, most widely spaced, based on 245 beam-column joint tests from studies by Marques and Jirsa (1975), Pinc et al. (1977), Hamad et al. (1993), Ramirez and Russell (2008), Lee and Park (2010), and Sperry et al. (2015a). The equation, shown as Eq. (2.1), has a mean test-to-calculated strength ratio of 1.0, and a coefficient of variation and standard deviation are 0.113.

The test-to-calculated strength ratios range between 0.68 and 1.28:

$$T_h = 332 f_{cm}^{0.29} \ell_{eh}^{1.06} d_b^{0.54} + 54,250 \left(\frac{NA_{tr}}{n} \right)^{1.06} d_b^{0.59} \quad (2.1)$$

where T_h is the anchorage strength of widely-spaced hooked bars (lb), f_{cm} is the measured concrete compressive (psi), ℓ_{eh} is the embedment length of the hooked bar measured from the face of the column to the end of the hook (in.), d_b is the hooked bar diameter (in.), A_{tr} is area of one leg of

confining reinforcement (in.^2), N is the number of legs of confining reinforcement within $8d_b$ from the top of the hooked bar for No. 8 (No. 25) bars and smaller or within $10d_b$ for No. 9 (No. 28) bars or larger, and n is the number of hooked bars in the joint confined by N legs.

Figure 2.7 shows the ratio of average bar force at failure T to the calculated bar force T_h for specimens without confining reinforcement based on Eq. (2.1) versus center-to-center spacing between hooked bar normalized to bar diameter c_{ch}/d_b . The data include the specimens used to develop Eq. (2.1) and the specimens containing three or four closely-spaced hooked bars in this study. The figure shows that there is a reduction in strength for hooked bars in specimens with three or four hooked bars with a center-to-center spacing of $7d_b$ or less.

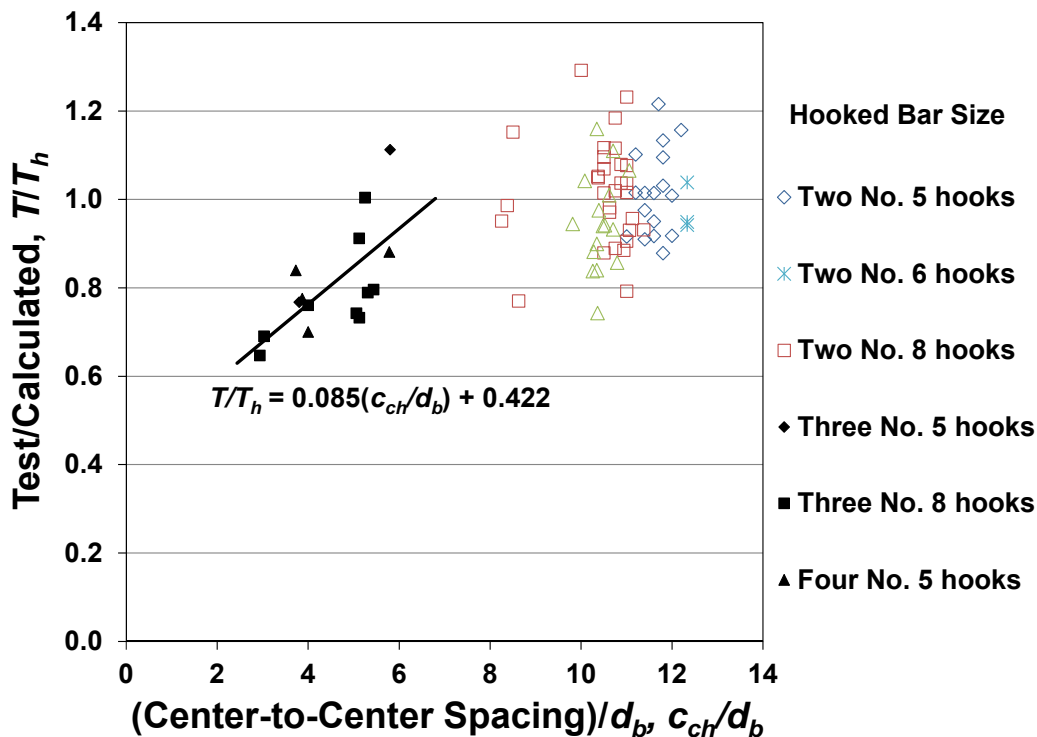

Figure 2.7 Ratio of test-to-calculated force T/T_h versus center-to-center spacing normalized to bar diameter c_{ch}/d_b for specimens with widely and closely-spaced hooked bars without confining reinforcement, with calculated values based on Eq. (2.1)

Based on the best-fit line shown in Figure 2.7 for the specimens containing three or four closely-spaced hooked bars without confining reinforcement (Table 2.1), the ratio of the anchorage strength of closely-spaced hooked bars to the anchorage strength of widely-spaced hooked bars is

$$0.085 \frac{c_{ch}}{d_b} + 0.422 \leq 1.0 \quad (2.2)$$

where c_{ch} is the center-to-center spacing between hooked bars (in.) and d_b is the hooked bar diameter (in.). The ratio is equal to 1.0 when the center-to-center spacing c_{ch} is greater than $7d_b$. This suggests that for a spacing greater than $7d_b$, hooked bars are far enough apart so that they do not interact, and therefore, can be treated as widely-spaced. Multiplying the first term of Eq. (2.1) by the ratio in Eq. (2.2) gives the anchorage strength of hooked bars without confining reinforcement.

$$T_h = 332 f_{cm}^{0.29} \ell_{eh}^{1.06} d_b^{0.54} \left(0.085 \frac{c_{ch}}{d_b} + 0.422 \right) \quad (2.3)$$

Figure 2.8 shows the test-to-calculated strength ratio T/T_h based on Eq. (2.3) for the specimens containing closely and widely-spaced hooked bars without confining reinforcement versus the center-to-center spacing normalized to bar diameter c_{ch}/d_b . The best-fit line represents all specimens in the figure. The ratio of the anchorage strength of closely-spaced to widely-spaced hooked bars in Eq. (2.3) is applied to specimens with center-to-center spacing less than and equal to $7d_b$. The average test-to-calculated strength ratio is 1.0 with a standard deviation of 0.12. The range of the test-to-calculated ratio for specimens with center-to-center spacing less than or equal to $7d_b$ is 0.86 to 1.22; the range for all specimens shown in Figure 2.8 is 0.73 to 1.29. Figure 2.8 shows that Eq. (2.3) accurately accounts for the effect of closely spaced hooked bars without confining reinforcement.

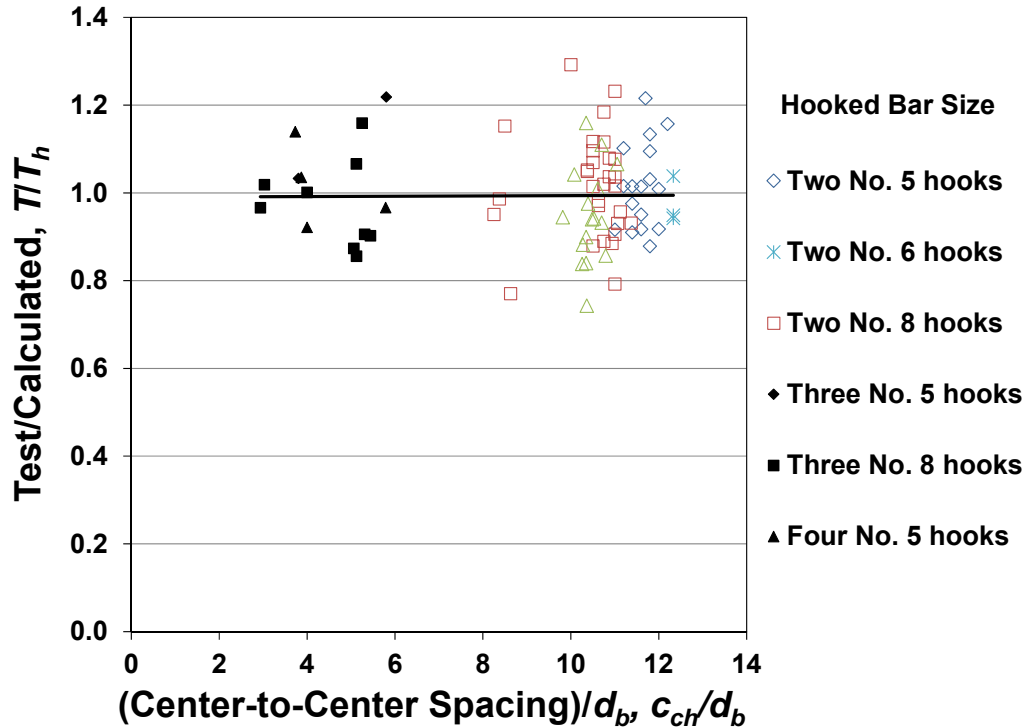

Figure 2.8 Ratio of test-to-calculated force T/T_h versus center-to-center spacing normalized to bar diameter c_{ch}/d_b for specimens with widely and closely-spaced hooked bars without confining reinforcement, calculated values based on Eq. (2.3)

Figure 2.9 shows the test-to-calculated anchorage strength ratio T/T_h versus center-to-center spacing between hooked bars normalized to bar diameter c_{ch}/d_b for specimens with five No. 3 (No. 10) hoops as confining reinforcement (Table 2.2). Based on Eq. (2.1), only hoops located within 8 or $10d_b$, from the top of the hooked bar, depending on the bar size, are contributing to anchorage strength. Three hoops out of five are considered here, representing a value of NA_{tr}/n of 0.22 . Comparing Figures 2.7 and 2.9, it can be seen that Eq. (2.1) is also unconservative for specimens with three or four hooked bars with confining reinforcement, but that the reduction in strength due to close spacing between hooked bars is not as great as for specimens without confining reinforcement. Based on the best-fit line for the specimens with three or four closely-spaced hooked bars with confining reinforcement shown in Figure 2.9, the ratio of the anchorage

strength for closely-spaced hooked bars to the anchorage strength of widely-spaced hooked bars is represented by

$$0.024 \frac{c_{ch}}{d_b} + 0.788 \leq 1.0 \quad (2.4)$$

The ratio is equal to 1.0 when the center-to-center spacing is greater than approximately $9d_b$.

Since Eq. (2.3) and (2.4) are associated with NA_{tr}/n of 0 and 0.22, respectively, a smooth transition for values of NA_{tr}/n between 0 and 0.22 is needed. To aid in developing a transition, Eq. (2.4) is modified so that it will provide a value of 1.0 at the same spacing, $7d_b$, as Eq. (2.3). Doing so gives

$$0.035 \frac{c_{ch}}{d_b} + 0.740 \leq 1.0 \quad (2.5)$$

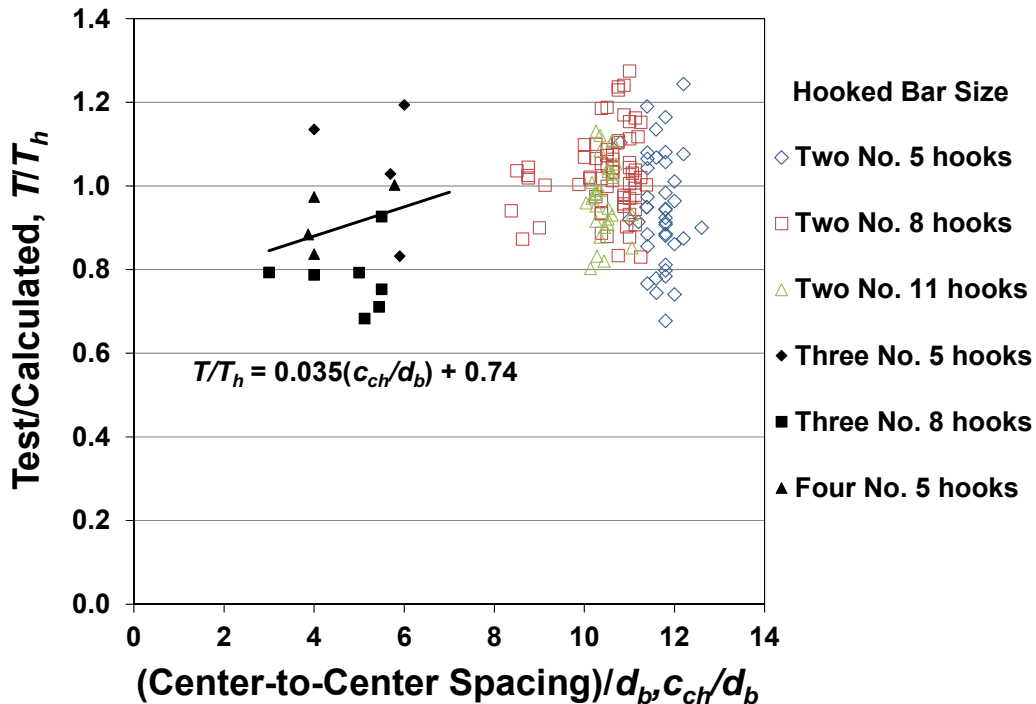

Figure 2.9 Ratio of test-to-calculated force T/T_h versus center-to-center spacing normalized to bar diameter c_{ch}/d_b for specimens with widely and closely-spaced hooked bars with confining reinforcement, calculated values based on Eq. (2.3)

To account for the effect of closely-spaced hooked bars for specimens with confining reinforcement, where NA_{tr}/n equals 0.22, the hooked bar anchorage strength calculated using Eq. (2.1) is multiplied by the ratio in Eq. (2.5) to get:

$$T_h = \left[332 f_{cm}^{0.29} \ell_{eh}^{1.06} d_b^{0.54} + 54,250 \left(\frac{NA_{tr}}{n} \right)^{1.06} d_b^{0.59} \right] \left(0.035 \frac{c_{ch}}{d_b} + 0.74 \right) \quad (2.6)$$

More generally for values of NA_{tr}/n between 0 and 0.22, hooked bar anchorage strength can be expressed as

$$T_h = \left[332 f_{cm}^{0.29} \ell_{eh}^{1.06} d_b^{0.54} + 54,250 \left(\frac{NA_{tr}}{n} \right)^{1.06} d_b^{0.59} \right] \omega_s \quad (2.7)$$

Where

$$\omega_s = \frac{NA_{tr}/n}{0.22} \left[\left(0.035 \frac{c_{ch}}{d_b} + 0.74 \right) - \left(0.085 \frac{c_{ch}}{d_b} + 0.42 \right) \right] + \left(0.085 \frac{c_{ch}}{d_b} + 0.42 \right) \quad (2.8)$$

where $\frac{NA_{tr}}{n} + (0.59) \leq \omega_s \leq 1.0$.

Figure 2.10 shows the test-to-calculated strength ratio based on Eq. (2.7) for the specimens containing closely-spaced hooked bars with confining reinforcement, including specimens with NA_{tr}/n below 0.22, versus center-to-center spacing normalized to bar diameter c_{ch}/d_b , along with specimens with widely-spaced hooked bars with confining reinforcement. The best-fit line represents all the specimens with closely and widely-spaced hooked bars. The average test-to-calculated strength ratio is 1.00 with a standard deviation of 0.147. The range of the test-to-calculated ratio for specimens containing three or four hooked bars is 0.74 to 1.29; the range for all specimens shown in Figure 2.12 is 0.68 to 1.29. Figure 2.10 shows that Eq. (2.7) is able to account for the effect of closely spaced hooked bars with confining reinforcement.

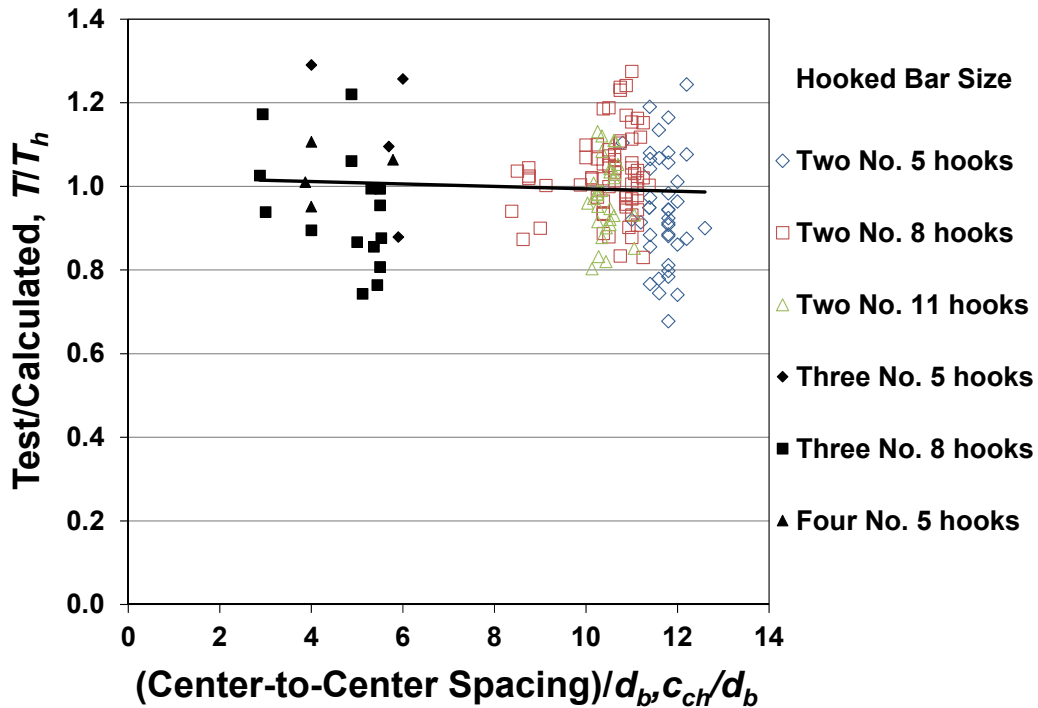

Figure 2.10 Ratio of test-to-calculated force T/T_h versus center-to-center spacing normalized to bar diameter c_{ch}/d_b for specimens with widely and closely-spaced hooked bars with confining reinforcement, calculated values based on Eq. (2.7)

Equation (2.7) capture the effect of having closely-spaced hooked bars in a beam-column joint. For the specimens with three or four closely-spaced hooked bars, the mean and standard deviation (STD) for the test-to-calculated strength ratio T/T_h are, respectively, 1.00 and 0.108 for specimens without confining reinforcement, and 1.00 and 0.147 for specimens with confining reinforcement. Table 2.6 shows the maximum, minimum, mean, standard deviation, and the coefficient of variation (COV) of the test-to-calculated anchorage strength ratio individually for specimens with three or four closely-spaced hooked bars and specimens with two hooked bars based on Eq. (2.7) for specimens without and with confining reinforcement.

Table 2.6 Ratio of test-to-calculated force T/T_h for specimens closely and widely-spaced hooked bars with calculated values T_h based on Eq. (2.7)

(No. of specimens)	Closely-spaced hooked bars (40 specimens)		Widely-spaced hooked bars (245 specimens)	
	Specimens without confining reinforcement (15)	Specimens with confining reinforcement (25)	Specimens without confining reinforcement (99)	Specimens with confining reinforcement (146)
Max.	1.22	1.29	1.29	1.28
Min	0.86	0.74	0.73	0.68
Mean	1.00	1.00	1.00	1.00
STD/COV	0.108	0.147	0.12	0.11

2.4.4 Measured total force versus calculated total force

This section includes an analysis of the effect of number of hooked bars on the measured total force for the 40 specimens in Tables 2.1 and 2.2. To evaluate the effect on total force as the number of hooked bars in a beam-column joint is increased, the measured total force in the specimens is compared to $2T_h$, where T_h is calculated using Eq. (2.1), the anchorage force for a single hooked bar in a specimen containing two hooked bars. Thus, the ratio of the total force to $2T_h$ provides a measure of the effect of additional hooked bars on anchorage strength. Table 2.7 shows the measured total anchorage force T_{total} , the measured average anchorage force per bar T , the calculated anchorage force per bar using Eq. (2.1) T_h , the ratios T/T_h and $T_{total}/2T_h$. The results are summarized in Table 2.8.

As demonstrated in Section 2.4.2, the value of T/T_h is less than 1.0 for most (33 out of 40) of the specimens. The mean value of $T_{total}/2T_h$ is 1.39 for all 40 specimens in Tables 2.1 and 2.2, 1.32 for the 15 specimens without confining reinforcement, and 1.43 for the 25 specimens with confining reinforcement. For specimens with three hooked bars, the mean value of $T_{total}/2T_h$ is 1.28 for all 30 specimens, 1.22 for the 11 specimens without confining reinforcement, and 1.32 for the

19 specimens with confining reinforcement. For specimens with four hooked bars, the mean value of $T_{\text{total}}/2T_h$ is 1.72 for all 10 specimens, 1.60 for the four specimens without confining reinforcement, and 1.80 for the six specimens with confining reinforcement. The results show that although in over 80 percent of the cases T/T_h is less than 1.0, the mean value of $T_{\text{total}}/2T_h$ for specimens with four hooked bars is higher than that for specimens with three hooked. This indicates that while the force per bar decreased as the number of bars within a given width increased, the total force in these beam-column joints increased. Also, compared to specimens with three or four hooked bars without confining reinforcement, $T_{\text{total}}/2T_h$ is higher for specimens with confining reinforcement, coinciding with the previous findings for the effect of confining reinforcement in reducing the spacing effect on anchorage strength.

Table 2.7 Measure versus calculated forces calculated forces using Eq. 2.1 for specimens in Table 2.1 and 2.2

	Specimen	T_{total} lb	T lb	T_h lb	T/T_h	$T_{total}/2T_h$
1	(4@4) 5-5-90-0-i-2.5-2-6	58167	14542	18697	0.78	1.56
2	(4@4) 5-5-90-0-i-2.5-2-10	113608	28402	33820	0.84	1.68
3	(4@4) 5-8-90-0-i-2.5-2-6	61916	15479	22136	0.70	1.40
4	(4@6) 5-8-90-0-i-2.5-2-6	77211	19303	21896	0.88	1.76
5	(3@4) 5-8-90-0-i-2.5-2-6	50416	16805	21890	0.77	1.15
6	(3@6) 5-8-90-0-i-2.5-2-6	74657	24886	22384	1.11	1.67
7	(4@4) 5-5-90-2#3-i-2.5-2-6	85621	21405	24752	0.86	1.73
8	(4@4) 5-5-90-2#3-i-2.5-2-8	104069	26017	31464	0.83	1.65
9	(3@6) 5-8-90-5#3-i-2.5-2-6.25	77489	25830	31014	0.83	1.25
10	(3@4) 5-8-90-5#3-i-2.5-2-6 [‡]	104667	34889	30735	1.14	1.70
11	(3@6) 5-8-90-5#3-i-2.5-2-6 [‡]	109345	36448	30409	1.20	1.80
12	(4@4) 5-5-90-5#3-i-2.5-2-7	108458	27114	32345	0.84	1.68
13	(4@4) 5-5-90-5#3-i-2.5-2-6	103591	25898	29304	0.88	1.77
14	(4@6) 5-8-90-5#3-i-2.5-2-6 [‡]	113284	28321	28229	1.00	2.01
15	(4@4) 5-8-90-5#3-i-2.5-2-6 [‡]	109970	27493	28238	0.97	1.95
16	(3@6) 5-8-90-5#3-i-3.5-2-6.25	105803	35268	34316	1.03	1.54
17	(3@5.5) 8-5-90-0-i-2.5-2-16	188393	62798	79580	0.79	1.18
18	(3@5.5) 8-5-90-0-i-2.5-2-10	108161	36054	45333	0.80	1.19
19	(3@3) 8-5-90-0-i-2.5-2-10 [‡]	85439	28480	44067	0.65	0.97
20	(3@5) 8-5-90-0-i-2.5-2-10 [‡]	96899	32300	44159	0.73	1.10
21	(3@5.5) 8-8-90-0-i-2.5-2-8	113010	37670	41310	0.91	1.37
22	(3@3) 8-12-90-0-i-2.5-2-12 [‡]	144116	48039	69551	0.69	1.04
23	(3@4) 8-12-90-0-i-2.5-2-12 [‡]	167466	55822	73348	0.76	1.14
24	(3@5) 8-12-90-0-i-2.5-2-12 [‡]	157056	52352	70564	0.74	1.11
25	(3@5) 8-5-180-0-i-2.5-2-10 [‡]	137789	45930	45732	1.00	1.51
26	(3@5.5) 8-5-90-2#3-i-2.5-2-14	171782	57261	74933	0.76	1.15
27	(3@5.5) 8-5-90-2#3-i-2.5-2-8.5	122656	40885	47452	0.86	1.29
28	(3@5.5) 8-5-90-2#3-i-2.5-2-14(1)	196009	65336	73789	0.89	1.33
29	(3@5.5) 8-5-90-2#3-i-2.5-2-8.5(1)	97104	32368	40881	0.79	1.19
30	(3@3) 8-5-90-2#3-i-2.5-2-10 [‡]	122162	40721	47726	0.85	1.28
31	(3@5) 8-5-90-2#3-i-2.5-2-10 [‡]	134004	44668	50186	0.89	1.34
32	(3@5.5) 8-5-90-5#3-i-2.5-2-8	111379	37126	49274	0.75	1.13
33	(3@5.5) 8-5-90-5#3-i-2.5-2-12	198283	66094	71299	0.93	1.39
34	(3@5.5) 8-5-90-5#3-i-2.5-2-8(1)	94108	31369	45944	0.68	1.02
35	(3@5.5) 8-5-90-5#3-i-2.5-2-12(1)	143554	47851	67364	0.71	1.07
36	(3@3) 8-5-90-5#3-i-2.5-2-10 [‡]	141829	47276	54870	0.86	1.29
37	(3@5) 8-5-90-5#3-i-2.5-2-10 [‡]	183916	61305	55173	1.11	1.67
38	(3@3) 8-12-90-5#3-i-2.5-2-12 [‡]	186619	62206	78424	0.79	1.19
39	(3@4) 8-12-90-5#3-i-2.5-2-12 [‡]	194819	64940	82451	0.79	1.18
40	(3@5) 8-12-90-5#3-i-2.5-2-12 [‡]	194282	64761	81719	0.79	1.19

Table 2.8 Summary of results in Table 2.7 showing mean, maximum, and minimum of $T_{total}/2T_h$ and T/T_h

		Max	Min	Mean	No. of specimens
$T_{total}/2T_h$	All specimens (with and without confining)				
	All specimens (3 and 4 hooked bars)	2.01	0.97	1.39	40
	3 hooks	1.80	0.97	1.28	30
	4 hooks	2.01	1.40	1.72	10
	Specimens without confining reinforcement				
	All specimens (3 and 4 hooked bars)	1.76	0.97	1.32	15
	3 hooks	1.67	0.97	1.22	11
	4 hooks	1.76	1.40	1.60	4
	Specimens with confining reinforcement				
	All specimens (3 and 4 hooked bars)	2.01	1.02	1.43	25
	3 hooks	1.80	1.02	1.32	19
	4 hooks	2.01	1.65	1.80	6
	T/T_h	All specimens (with and without confining)			
All specimens (3 and 4 hooked bars)		1.20	0.65	0.86	40
3 hooks		1.20	0.65	0.85	30
4 hooks		1.00	0.70	0.86	10
Specimens without confining reinforcement					
All specimens (3 and 4 hooked bars)		1.11	0.65	0.81	15
3 hooks		1.11	0.65	0.81	11
4 hooks		0.88	0.70	0.80	4
Specimens with confining reinforcement					
All specimens (3 and 4 hooked bars)		1.20	0.68	0.88	25
3 hooks		1.20	0.68	0.88	19
4 hooks		1.00	0.83	0.90	6

2.5 SUMMARY AND CONCLUSIONS

In this study, 40 simulated beam-column joint specimens were tested to investigate the effect of bar spacing on anchorage strength. The specimens contained three or four No. 5 or No. 8 (No. 16 or No. 25) hooked bars with center-to-center spacing between the bars ranging from 3 to

$6d_b$. The results for these specimens were compared with those for 245 specimens containing two hooked bars with center-to-center spacing between hooked bars between $3d_b$ and $12d_b$. The specimens were cast using normalweight concrete and contained three or four closely-spaced hooked bars. Sixteen specimens contained No. 5 (No. 16) hooked bars, of which six had no confining reinforcement and 10 had two or five No. 3 (No. 10) hoops parallel to the straight portion of the hooked bar as confining reinforcement in the joint region. The remaining 24 specimens contained No. 8 (No. 25) hooked bars, of which 9 had no confining reinforcement and 15 had two or five No. 3 (No. 10) hoops as confining reinforcement in the joint region. The concrete compressive strength ranged from 4,490 to 11,460 psi (31 to 79 MPa), and embedment length ranged from 5.2 to 16.1 in. (132 to 409 mm). The center-to-center spacing between hooked bars ranged from 3 to $6d_b$, and the stresses in the hooked bars at anchorage failure ranged from 36,100 to 117,100 psi (249 to 808 MPa). The descriptive equation by Sperry et al. (2015b, 2017b) to calculate the anchorage strength of two widely-spaced hooked bars is modified to account for the effect of closely-spaced hooked bars for specimens with more than two hooked bars without and with confining reinforcement.

The following conclusions are based on the results and analysis described in this chapter:

1. Front Failure was the dominant failure mode for specimens containing more than two hooked bars.
2. The anchorage strength of hooked bars in joints with three or four bars decreased with center-to-center spacing of $7d_b$ or less. The addition of confining reinforcement mitigated but did not eliminate this effect.

3. The modification to the descriptive equation by Sperry et al. (2015b, 2017b) to calculate the anchorage strength of two widely-spaced hooked bars to account for the effect of low hooked bar spacing provides a reasonable representation of the anchorage strength of closely-spaced hooked bars.
4. While the force per bar decreased as the number of bars within a given width increased, the total anchorage force for the hooked bars in the simulated beam-column joints remained constant or increased as the number of hooked bars increased.

2.6 REFERENCES

ACI Committee 318, 2014, *Building Code Requirements for Structural Concrete* (ACI 318-14), American Concrete Institute, Farmington Hills, MI, 518 pp.

ASTM A615/A615M, 2015, *Standard Specification for Deformed and Plain Carbon-Steel Bars for Concrete Reinforcement* (ASTM A615/A615-15), ASTM International, West Conshohocken, PA., 8 pp.

ASTM A1035/A1035, 2014, *Standard Specification for Deformed and Plain Low-Carbon, Chromium, Steel Bars for Concrete Reinforcement* (ASTM A1035/A1035-14), ASTM International, West Conshohocken, PA., 7 pp.

ASTM C31/C31M-15ae1, *Standard Practice for Making and Curing Concrete Test Specimens in the Field* (ASTM C31/C31M-15), ASTM International, West Conshohocken, PA, 2015

ASTM C494/C494M-13, *Standard Specification for Chemical Admixtures for Concrete* (ASTM C494/C494M-13), ASTM International, West Conshohocken, PA, 2013, 10 pp.

ASTM C1017/C1017M-13, *Standard Specification for Chemical Admixtures for Use in Producing Flowing Concrete* (ASTM C1017/C1017M-13), ASTM International, West Conshohocken, PA, 2013, 9 pp.

Hamad, B. S., Jirsa, J. O., and d'Abreu d Paolo, N. I., 1993, "Anchorage Strength of Epoxy-Coated Hooked Bars," *ACI Structural Journal*, Vol. 90, No. 2, Mar.-Apr., pp. 210-217.

Lee, J. and Park, H., 2010, "Bending - Applicability Study of Ultra-Bar (SD 600) and Ultra-Bar for Rebar Stirrups and Ties (SD 500 and 600) for Compression Rebar," [*Translated from Korean*] *Korea Concrete Institute*, Aug. , pp. 504.

Marques, J. L. G. and Jirsa, J. O., 1975, "A Study of Hooked Bar Anchorages in Beam-Column Joints," *ACI Journal, Proceedings* Vol. 72, No. 5, May, pp. 198-209.

Peckover, J. and Darwin, D., 2013, "Anchorage of High-Strength Reinforcing Bars with Standard Hooks: Initial Tests," *SL Report* No. 13-1, University of Kansas Center for Research, Lawrence, KS, 47 pp.

Pinc, R. L., Watkins, M. D., and Jirsa, J. O., 1977, "Strength of Hooked Bar Anchorages in Beam-Column Joints," *Report 77-3*, University of Texas, Austin, TX, 67 pp.

Ramirez, J. A. and Russell, B. W., 2008, "Transfer, Development, and Splice Length for Strand/reinforcement in High-strength Concrete," Transportation Research Board, National Research Council, Washington, D.C., 99-120 pp.

Searle, N., DeRubeis, M., Darwin, D., Matamoros, A., O'Reilly, M., and Feldman, L., 2014, "Anchorage of High-Strength Reinforcing Bars With Standard Hooks - Initial Tests," *SM Report* No. 108, University of Kansas Center for Research, Lawrence, KS, 120 pp.

Sperry, J., Al-Yasso, S., Searle, N., DeRubeis, M., Darwin, D., O'Reilly, M., Matamoros, A., Feldman, L., Lepage, A., Lequesne, R., and Ajaam, A., 2015a, "Anchorage of High-Strength Reinforcing Bars With Standard Hooks," *SM Report* No. 111, University of Kansas Center for Research, Lawrence, KS, 260 pp.

Sperry, J., Darwin, D., O'Reilly, M., and Lequesne, R., 2015b, "Anchorage Strength of Conventional and High-Strength Hooked Bars in Concrete," *SM Report* No. 115, University of Kansas Center for Research, Lawrence, KS, 281 pp.

Sperry, J., Yasso, S., Searle, N., DeRubeis, M., Darwin, D., O'Reilly, M., Matamoros, A., Feldman, L., Lepage, A., Lequesne, R., and Ajaam, A., 2017a, "Conventional and High-Strength Hooked Bars—Part 1: Anchorage Tests," Vol. 114, No. 1, Jan.-Feb., pp. 255-266.

Sperry, J., Darwin, D., O'Reilly, M., Lequesne, R., Yasso, S., Matamoros, A., Feldman, L., and Lepage, A., 2017b, "Conventional and High-Strength Hooked Bars—Part 2: Data Analysis," *ACI Structural Journal*, Vol. 114, No. 1, Jan.-Feb., pp. 267-276.

CHAPTER 3: EFFECT OF HOOKED BAR LOCATION AND TAIL COVER ON ANCHORAGE STRENGTH

3.1 INTRODUCTION

Hooks are used to anchor steel reinforcing bars where insufficient space is available to develop straight bars, such as in exterior beam-to-column, slab-to-beam, or slab-to-wall connections. Anchorage strength is affected by confinement around the hooked bar, which can be provided by column ties, concrete cover, or column longitudinal reinforcement. Although placing the hooked bars within a column but outside the column core is not a common practice, placement of hooked bars in unconfined concrete does occur in cantilever beams and slabs where no longitudinal reinforcement perpendicular to the hooked bar is provided. Marques and Jirsa (1975) compared the anchorage performance of hooked bars placed outside the column core with those placed inside the column core. The load-slip curves had a similar shape in all cases, but for most specimens, hooked bars placed outside the column core had slightly lower bar stress at a given value of slip; Marques and Jirsa concluded that anchorage strength was not affected due to bar placement with respect to column longitudinal reinforcement. The study did, however, find that anchorage strength increases as side and tail cover to the hooked bar increase and if confining reinforcement is provided at the joint region. More recently, Sperry et al. (2015a, 2017a) observed that failure adjacent to the tail of 90° hooks (described as tail kickout) appeared to be a secondary failure, not affecting the anchorage strength of hooked bars.

The placement of hooked bars with respect to the depth of the column is not addressed in the development length provisions for hooked bars in ACI 318-14. In practice, hooked bars are usually extended to the far side of the column, even if the calculated embedment length allows a shallower embedment. However, this is not required for non-seismic structures. Joh et al. (1995)

tested 34 simulated beam-column joints. The majority of which had hooked bars embedded halfway through the column depth. One direct comparison was performed using three specimens with hooked bars embedded $\frac{1}{3}$, $\frac{1}{2}$, and $\frac{4}{5}$ of the column depth. The specimens with shallower embedments exhibited lower anchorage strength than would be predicted based on the reduction in embedment length alone, implying that the position of hooked bars with respect to the column depth and the lack of compressive stress in the concrete around the hook may reduce anchorage strength.

This study considers the effects of hooked bar placement and tail cover. Failure modes are identified and anchorage strengths are compared with values based on a descriptive equation developed for simulated beam-column joints that contained two widely-spaced hooked bars proposed by Sperry et al. (2015b, 2017b).

3.2 RESEARCH SIGNIFICANCE

The design provisions for hooked bars in ACI 318-14 and the AASHTO LRFD Bridge Design Specifications (2012) are based on a limited number of tests and do not account for the effect of hooked bar placement on anchorage strength. To better understand of the effect of hooked bar placement, this study investigated the effects of hooked bar location (inside or outside the column core), embedding the hooked bar halfway through the depth of the column, and not complying with the ACI 318-14 minimum tail cover requirements.

3.3 EXPERIMENTAL PROGRAM

This chapter describes a study that is part of a larger experimental program to investigate the behavior and anchorage strength of hooked bars (Sperry et al. 2015a). The overall program included 338 beam-column joint specimens. The effect of concrete compressive strength, side

cover, hook bend angle, number of hooked bars, and center-to-center spacing were addressed by Sperry et al. (2015a, 2015b, 2017a, 2017b) and in Chapter 2. This chapter deals with a subset of these specimens. The effect of hooked bar location with respect to the column core was studied by testing 37 simulated beam-column joints containing No. 5, No. 8, and No 11 (No. 16, No. 25, and No. 36) hooked bars placed outside the column core and comparing the results with those for 144 specimens containing hooked bars placed inside the column core. Average embedment lengths ranged from 4.75 to 25.2 in. (121 to 640 mm), average side cover ranged from 1.5 to 4.2 in. (38 to 106 mm), concrete compressive strengths ranged from 4,420 to 11,800 psi (30.5 to 81 MPa), and stresses at failure for hooked bars ranged from 41,800 to 141,600 psi (288 to 976 MPa). The average embedment length and side cover are based on the hooked bars in an individual specimen. Out of the 37 specimens, 18 contained no confining reinforcement and 19 contained two, five, or six No. 3 (No. 10) hoop ties as confining reinforcement. Five No. 3 (No. 10) bar hoops were used to confine No. 5 and No. 8 (No. 16 and No. 25) hooked bars and six were used to confine No. 11 (No. 36) hooked bars, both of which qualify for the 0.8 development length modification factor permitted by Section 25.4.3.2 of ACI 318-14. A subset of ten specimens from the 37 specimens with hooked bars placed outside the column core had 11 companion specimens with the hooked bars placed inside the column core cast from the same concrete batches, allowing for direct comparison based on hooks bar placement.

The effect of hooked bar embedment within the column depth was examined by testing 24 specimens with hooked bars extended just halfway through the column depth. Ten of the specimens contained two No. 8 or No. 11 (No. 25 or No. 36) hooked bars with average tail covers ranging from 8.1 to 16.6 in. (205 to 422 mm), concrete compressive strengths ranging from 5,280

to 7,710 psi (36 to 53 MPa), and stresses in the hooked bars at failure ranging from 38,600 to 80,100 psi (266 to 552 MPa). Four specimens contained no confining reinforcement and six contained two, five, or six No. 3 (No. 10) hoops within the joint region. The remaining fourteen specimens contained three or four No. 5, 8, or 11 (No. 16, 25, or 36) hooked bars with average tail covers ranging from 5.6 to 17.4 in. (143 to 441 mm), concrete compressive strengths ranging from 5,280 to 7,510 psi (36 to 52 MPa), and failure stresses in the hooked bars ranging from 27,100 to 100,500 psi (187 to 693 MPa). Six of these specimens contained no confining reinforcement, and eight specimens contained confining reinforcement consisting of two, five, or six No. 3 (No. 10) hoops within the joint region.

The effect of low tail cover on anchorage strength and mode of failure was examined using 208 specimens with two hooked bars. Of the total of 399 hooked bars, where some specimens had usable data for only one of the two hooked bars and nine are not included in the analysis because the hooked bar yielded or the load reached the maximum capacity of the test apparatus. Tail cover ranged from 0.75 to 3.63 in. (29 to 92 mm). The 2-in. (50-mm) tail cover required by Section 25.4.3.2 of ACI 318-14 was used as the threshold for comparing the hooked bar performance. Concrete compressive strengths ranged from 4,420 to 16,510 psi (30 to 114 MPa), and failure stresses in the hooked bars ranged from 33,000 to 141,000 psi (228 to 972 MPa). The details of the test specimens used in this analysis are presented in Appendix B.

3.3.1 Test Specimens

The test specimens in this study (Figures 3.1 and 3.2) were designed to simulate an exterior beam-column joint. The specimens shown in Figure 3.1 represent joints containing two hooked bars inside and outside the column core with 2 in. (50 mm) concrete cover to the tail of the hook.

Side cover for the specimens ranged from 1.5 to 4.5 in. (38 to 114 mm) with 2.5 or 3.5-in. (64 or 89-mm) side cover used for the majority of the specimens.

The specimens in Figure 3.2 represent a beam-column joint containing two, three and four hooked bars that extend halfway through the column depth.

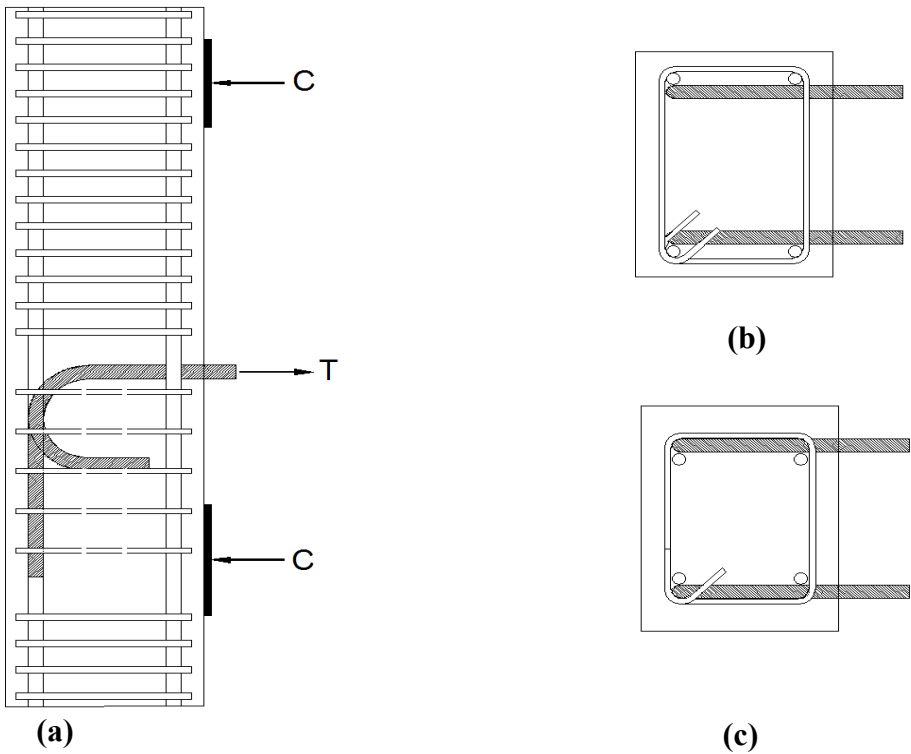

Figure 3.1 Schematic of typical specimen (a) side view of specimen (b) cross-section of specimen with two hooks inside the column core with confining reinforcement (c) cross-section of specimen with three hooks outside the column core with confining reinforcement

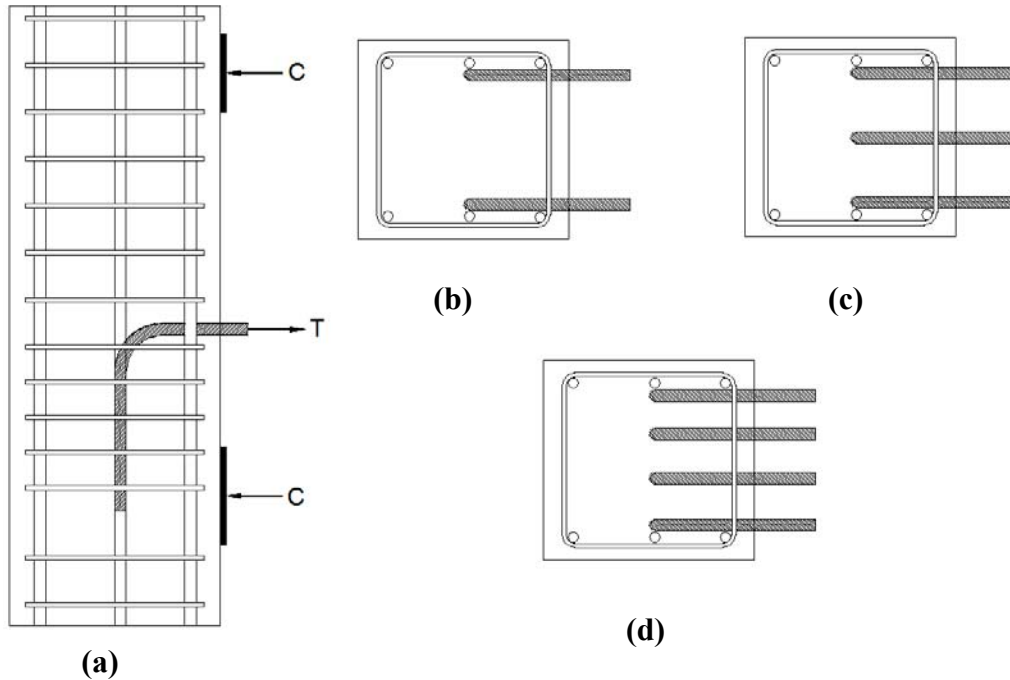
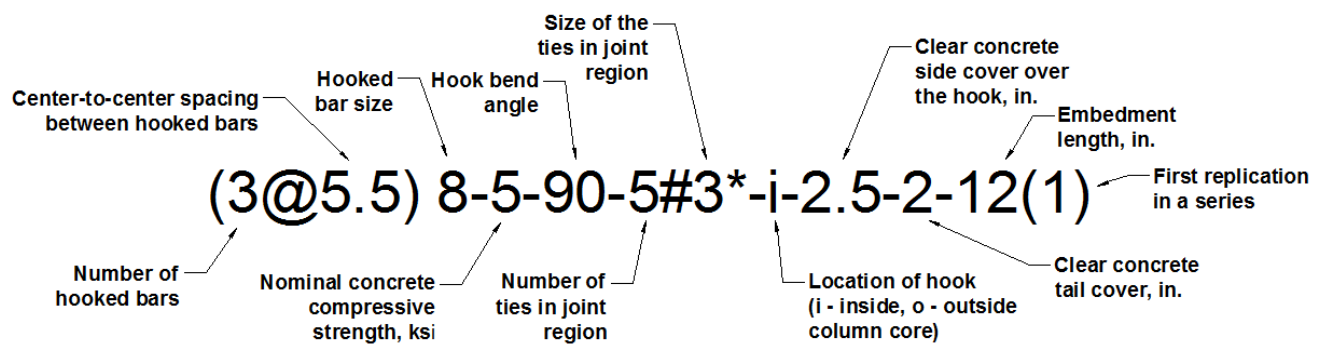

Figure 3.2 Schematic of specimen with hooked bar extended halfway through the column depth (a) side view of specimen (b) cross-section of specimen with two hooks inside the column core with confining reinforcement (c) cross-section of specimen with three hooks inside the column core with confining reinforcement (d) cross-section of specimen with four hooks inside the column core with confining reinforcement

Each specimen had a unique designation that includes its key parameters, as illustrated in Figure 3.3.



* For the vertical confining reinforcement, size of the ties in hook region is followed by 'vr', and its absence indicates that the horizontal confining reinforcement is provided.

Figure 3.3 Example specimen designation

In this study, *embedment length* ℓ_{eh} refers to the distance measured from the column face to the back of the tail of the hook, while *development length* ℓ_{dh} refers to the minimum length required in Section 25.4.3 of ACI 318-14 to ensure a bar can develop its specified yield strength. Embedment lengths ℓ_{eh} were chosen to ensure anchorage failure prior to bar yielding. In early tests, embedment length was equal to 80% of the development length defined in ACI 318-14; for later tests, ℓ_{eh} was calculated by extrapolating trends from test results.

The desired concrete cover to the hook tail was added to the embedment length to determine the depth of the specimen. The desired side cover was added to the center-to-center spacing plus hooked bar diameter to determine the width of the specimen.

Column reinforcement was designed to provide adequate flexural and shear strength assuming all hooked bars in a specimen reached their anticipated peak load simultaneously. Different levels of confining reinforcement were provided within the joint region to determine the effect on anchorage strength. The height of the column was selected so that the top reaction would not interfere with the failure region. A column height of $52\frac{3}{4}$ in. (1,340 mm) was used for specimens containing No. 5 or No. 8 (No. 16 or No. 25) hooked bars and 96 in. (2,440 mm) for the specimens with No. 11 (No. 36) hooked bars.

3.3.2 Material Properties

Normalweight concrete with nominal compressive strengths of 5,000, 8,000, 12,000 and 15,000 psi (34, 55, 83 and 103 MPa) was used in the study. Actual compressive strengths ranged from 4,300 to 16,510 psi (30 to 114 MPa). Type I/II portland cement, crushed limestone with maximum aggregate size of $\frac{3}{4}$ in. (19 mm), and Kansas River sand were used in the concrete mixtures. Pea gravel was used for 12,000 psi (83 MPa) concrete to improve workability. To

achieve the required workability and strength, two types of polycarboxylate-based high-range water-reducing admixture were used: ADVA 140 was used in the 5,000 and 8,000-psi (34 and 55-MPa) concrete, and ADVA 575 was used in the 12,000 and 15,000 psi (83 and 103 MPa) concrete. Compared to ADVA 140, ADVA 575 has a lower addition rate and helps to achieve higher early concrete compressive strength. Both admixtures meet the requirements of ASTM C494, as a Type A and a Type F admixture, and ASTM C1017 as a Type I plasticizing admixture. Mixture proportions are listed in Table 3.1.

Table 3.1 Concrete mixture proportions

Material	Quantity (SSD)			
	5,000	8,000	12,000	15,000
Design Compressive Strength (psi)				
Type I/II Cement, lb/yd ³	600	700	750	760
Type C Fly Ash, lb/yd ³	-	-	-	160
Silica Fume, lb/yd ³	-	-	-	100
Water, lb/yd ³	263	225	217	233
Crushed Limestone ¹ , lb/yd ³	1,734	1,683	1,796	-
Granite ² , lb/yd ³	-	-	-	1,693
Pea Gravel ³ , lb/yd ³	-	-	316	-
Kansas River Sand ⁴ , lb/yd ³	1,396	1,375	1,050	1,138
Estimated Air Content, %	1	1	1	1
High-Range Water-Reducer, oz (US)	30 ⁵	171 ⁵	104 ⁶	205 ⁶
<i>w/cm</i> ratio	0.44	0.32	0.29	0.24

Bulk specific gravity (saturated surface dry) =¹2.60, ²2.61, ³2.59, and ⁴2.63

⁵ ADVA 140, ⁶ADVA 575

Note: 1 ksi = 6.89 MPa, 1 oz = 29.57 ml, and 1 lb/yd³ = 0.593 kg/m³

Table 3.2 shows the properties for the reinforcing steel used in the tests. The table includes yield and tensile strength, nominal diameter, deformation dimensions and spacing, and relative rib area for the deformed steel bars used as hooked bars. The hooked bars were fabricated from ASTM A1035 Grade 120 (830 MPa) steel, with the exception of some early tests that contained hooked bars fabricated from ASTM A615 Grades 60 and 80 (420 and 550 MPa) steel.

Table 3.2 Hooked bar properties

Bar Size	ASTM Designation	Yield Strength (ksi) ¹	Tensile Strength (ksi)	Nominal Diameter (in.)	Average Rib Spacing (in.)	Average Rib Height		Gap Width		Relative Rib Area ³
						A ² (in.)	B ³ (in.)	Side 1 (in.)	Side 2 (in.)	
5	A615	69	108	0.625	0.417	0.031	0.029	0.179	0.169	0.060
5	A1035	128	160	0.625	0.391	0.038	0.034	0.200	0.175	0.073
8	A615	76	95	1.0	0.666	0.059	0.056	0.146	0.155	0.073
8	A1035 ^a	131	167	1.0	0.686	0.068	0.065	0.186	0.181	0.084
8	A1035 ^b	135	168	1.0	0.574	0.057	0.052	0.16	0.157	0.078
8	A1035 ^c	129	168	1.0	0.666	0.056	0.059	0.146	0.155	0.073
11	A615	84	113	1.41	0.894	0.080	0.074	0.204	0.196	0.069
11	A1035	123 ⁴	164 ⁴	1.41	0.830	0.098	0.088	0.248	0.220	0.085

¹ From mill test report ² Per ASTM A615, A706. ³ Per ACI 408R-3 ⁴ from tensile test

^a Heat 1, ^b Heat 2, ^c Heat 3, 1 in. = 25.4 mm, 1 ksi = 6.89 MPa

Due to the high flexural demand for some columns, ASTM A1035 Grade 120 (830 MPa) reinforcing bars were occasionally used as longitudinal reinforcement, but most specimens contained ASTM A615 Grade 60 (420 MPa) bars. The details on the type of reinforcement used for individual specimens is given in Appendix B.

3.3.3 Loading System and Test Procedure

Figures 3.4a and b show the loading system used in this study, which is a modified version of the test frame used by Marques and Jirsa (1975). The system simulates the forces applied at an exterior beam-column joint by applying tensile loads to the hooked bars. The beam compression reaction is provided by the bearing member. The upper compression member prevents the column from overturning and is placed so as to not interfere with the failure region.

The test frame was designed to accommodate two (Figure 3.4a), three, or four (Figure 3.4b) hooked bars. The only difference between the two test frames was the steel channel sections added for specimens with three or four hooked bars to act as a spreader beam to distribute the load. A detailed description of the test apparatus is provided by Peckover and Darwin (2013).

The flange widths for the upper compression member and bearing member were $6\frac{5}{8}$ -in. (168 mm) and $8\frac{3}{8}$ -in. (213 mm), respectively. The locations of reaction forces for the different size hooked bars, measured from the center of the hooked bar, are shown in Table 3.3.

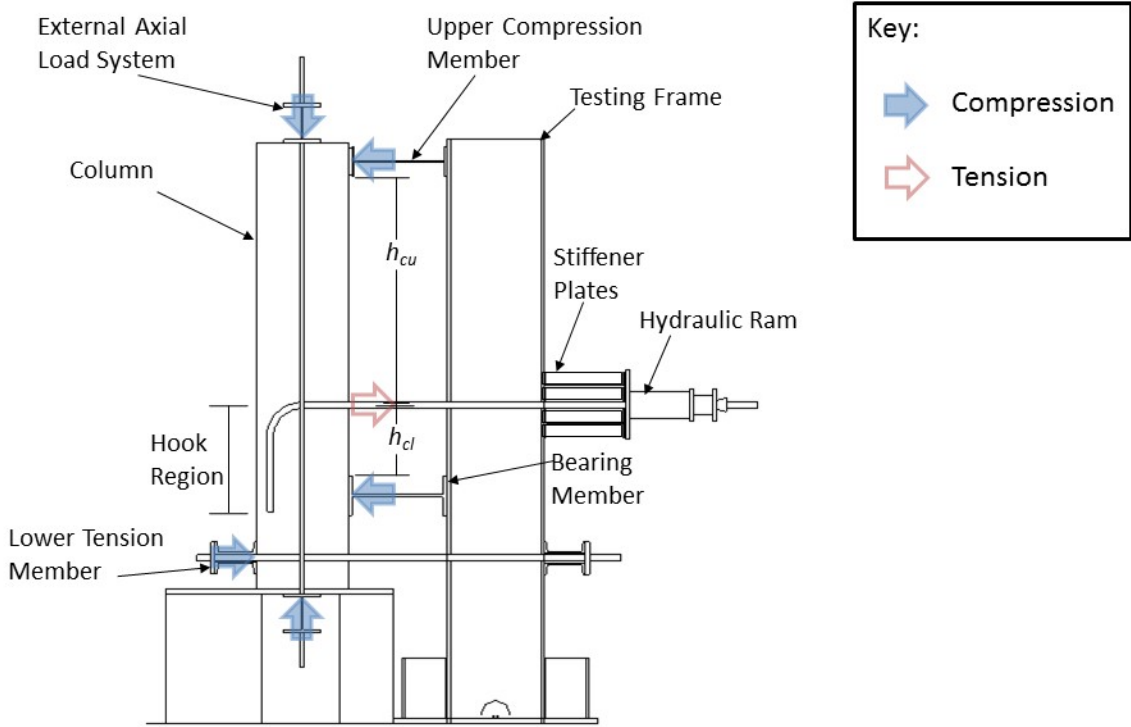

Figure 3.4a Test frame for two hooked bar specimens

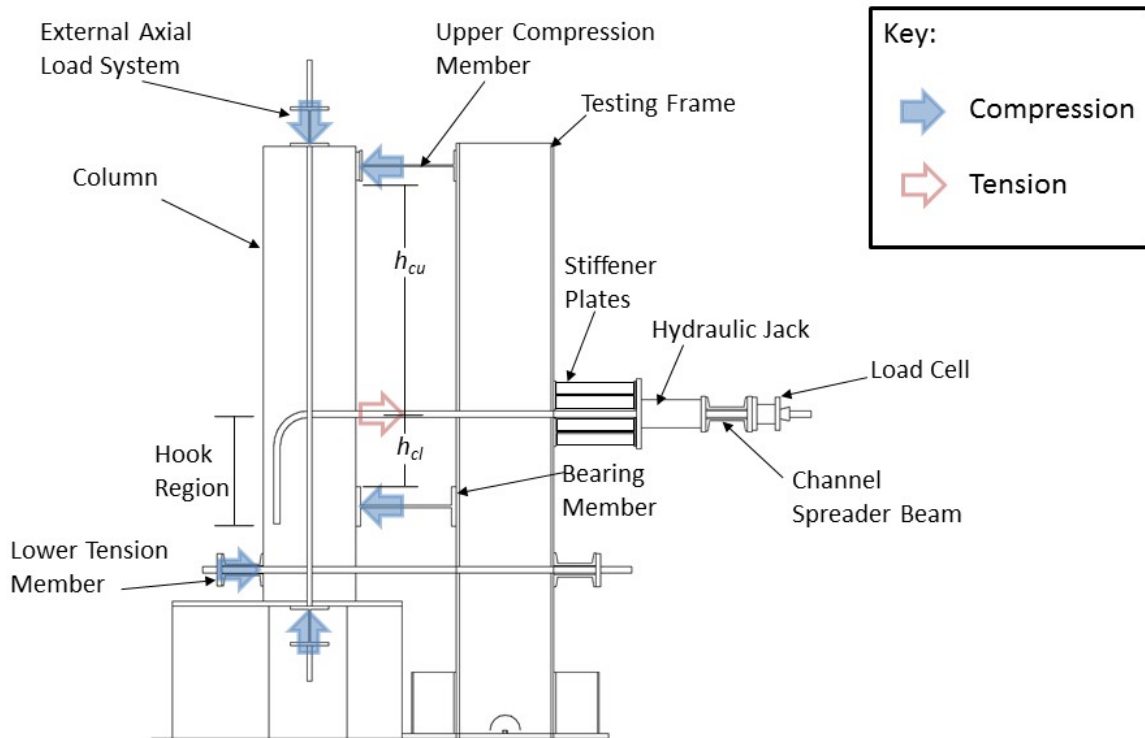

Figure 3.4b Test frame for specimens containing three or four hooked bars

Table 3.3 Location of reaction forces

	Size of Hooked Bar		
	No. 5	No. 8	No. 11
Height of Specimen, (in.) ¹	52¾	52¾	96
Distance from Center of Hook to Top of Bearing Member Flange, h_{cl} (in.) ¹	5¼	10	19½
Distance from Center of Hook to Bottom of Upper Compression Member Flange, h_{cu} (in.) ¹	18½	18½	48½

¹See Figure 3.4a and b, 1 in. = 25.4 mm

Axial compressive loads were placed on the column to more accurately simulate column loading conditions. In this study, a constant axial force of 30,000 lb (133,447 N) was applied to the specimens producing axial stresses of 90 to 460 psi (0.62 to 3.17 MPa) for No. 5 and No. 8 (No. 16 and No. 25) hooked bars and 280 psi (1.93 MPa) for specimens with No. 11 (No. 36)

hooked bars. Some of early tests had a constant force of 80,000 lb (356,000 N), which resulted in axial stress on specimens ranging from 505 to 1,930 psi (3.48 to 13.31 MPa). As described in Chapter 2, Marques and Jirsa (1975) found that differences in axial stress up to 3,000 psi (21 MPa) did not affect the anchorage strength of the hooked bars; thus, the effect of different values of axial stress was not examined in this study.

Hydraulic jacks were used to apply a tensile force to the hooked bars, simulating tensile forces in beam negative reinforcement. The tensile load was applied monotonically in steps of 5,000 or 10,000 lb (22,200 or 44,500 N) depending on the specimen size. Loading was paused after each step to allow cracks to be marked. The force on each hooked bar was measured using a load cell. Anchorage strength was taken as the average force per hooked bar corresponding to the maximum total force at failure. The maximum force for each hooked bar was also recorded and used when the individual hooked bar strength was evaluated, although this did not, in general, coincide with the maximum total force on the system.

3.4 TEST RESULTS AND DISCUSSION

This section describes the modes of failure observed during the tests. Anchorage strengths are compared for specimens from same batches that had hooked bars placed inside or outside the column core. For specimens in different batches, test-to-calculated strength ratios, calculated using a descriptive equation for two widely-spaced hooked bars developed by Sperry et al. (2015b, 2017b), are used to compare the differences in strength for hooked bars placed inside or outside the column core. This section also deals with the effects of placement of hooked bars within the column depth, ratio of effective depth to embedment length, tail kickout at failure, and concrete cover to the hook tail on anchorage strength.

3.4.1 Failure Modes

Three failure modes were observed for beam-column joint specimens in this portion of the study: front failure (F), in which a mass of concrete is pulled out with the hooked bars from the front of the face of the column; side failure (S), in which the side face of the column splits off after vertical cracks form in the plane of a hook; and tail kickout (TK), where the tail of a 90° hook pushes the concrete cover off of the back of the column. Tail kickout (TK) was only observed in conjunction with other failure types. The majority of the specimens containing two hooked bars experienced a combination of more than one failure mode, with front failure predominating; however, for specimens with three or four hooked bars (shown in Chapter 2), front failure was the only mode of failure for the majority of the specimens. Examples of the failure modes are shown in Figure 3.5.



(a)



(b)



(c)

Figure 3.5 Failure modes (a) Front Failure (F) (b) Side Failure (S) (c) Tail kickout (TK)

3.4.2 Effect of hooked bar location inside or outside the column core

Two types of comparisons are made to determine the effect of hooked bar location, inside or outside the column core, on anchorage strength. In the first, anchorage strengths are compared for specimens with the same geometry, with the exception of hooked bar location, cast from the same concrete batch. These specimens allow a direct comparison based on bar location alone. In the second, anchorage strengths are compared for specimens from different batches of concrete.

3.4.2.1 Comparison of hooked bars placed inside and outside column core cast from same concrete batch

For specimens cast from the same concrete batch, Table 3.4 summarizes the number of specimens in each batch, size and location of the hooked bars, and the amount of confining reinforcement.

Table 3.4 Groups* with hooked bars inside and outside the column core

Group	Number of specimens	Hooked bar size	Hook location	Confining reinforcement
1	3	No. 8 (No. 25)	Inside Core	None
	3		Outside Core	
2	3	No. 8 (No. 25)	Inside Core	No. 3 @ $3d_b$ (5 No. 3 hoops)
	3		Outside Core	
3	2	No. 11 (No. 36)	Inside Core	None
	2		Outside Core	
4	3	No. 11 (No. 36)	Inside Core	No. 3 @ $3d_b$ (6 No. 3 hoops)
	2		Outside Core	

*Individual specimens identified in Table 3.5

Table 3.5 shows the details for the specimens identified in Table 3.4. Average embedment lengths ranged from 7.8 to 17.1 in. (198 to 434 mm), concrete compressive strength ranged from 5,270 to 12,370 psi (36 to 85 MPa), and the average stress at failure ranged from 41,800 to 104,800 psi (288 to 723 MPa). The hook bend angle was 90° for the majority of the specimens; two specimens in Group 3 and three specimens in Group 4 that had hooks with a 180° bend angle.

Figure 3.6 shows the ratio of the strength of hooked bars placed outside the column core to the strength of hooked bars placed inside the column core for the companion specimens in Table 3.5, normalized to the compressive strength and embedment length $(T_{\text{outside}}/T_{\text{inside}})_N$. The anchorage strength is normalized to eliminate effects due to differences in concrete compressive strengths and embedment lengths for the companion specimens and is achieved by multiplying the anchorage strength by $(f_{cm,N}/f_{cm})^{0.29} \times (\ell_{eh,N}/\ell_{eh})^{1.06}$, where $f_{cm,N}$ and $\ell_{eh,N}$ are specified values for concrete compressive strength and embedment length, respectively. The ratio of the two strengths is

$$\frac{T_{\text{outside}} \left(\frac{f_{cm,N}}{f_{cm,\text{outside}}} \right)^{0.29} \left(\frac{\ell_{eh,N}}{\ell_{eh,\text{outside}}} \right)^{1.06}}{T_{\text{inside}} \left(\frac{f_{cm,N}}{f_{cm,\text{inside}}} \right)^{0.29} \left(\frac{\ell_{eh,N}}{\ell_{eh,\text{inside}}} \right)^{1.06}} = \frac{T_{\text{outside}} (f_{cm,\text{inside}})^{0.29} (\ell_{eh,\text{inside}})^{1.06}}{T_{\text{inside}} (f_{cm,\text{outside}})^{0.29} (\ell_{eh,\text{outside}})^{1.06}} \quad (3.1)$$

As demonstrated in Eq. (3.1), the specified values of compressive strength $f_{cm,N}$ and embedment length $\ell_{eh,N}$ used in normalizing the anchorage strength have no effect on the ratio $(T_{\text{outside}}/T_{\text{inside}})_N$ because the values cancel out when taking the ratio between the two anchorage strengths. The powers 0.29 and 1.06 for concrete compressive strength and embedment length used in normalizing the anchorage strengths are obtained from the analysis by Sperry et al. (2015b, 2017b) on the effect of different these factors on hooked bars and are shown in Eq. (3.2), shown in Section. 3.4.2.2. Figure 3.6 shows that hooked bars placed outside the column core, in general, exhibit lower strengths than hooked bars placed inside the column core. The ratios range from 0.66 to 0.96, with an average of 0.84.

Table 3.5 Test results for Groups 1 to 4 with hooked bars inside and outside the column core

Specimen	Hook	ℓ_{eh} in.	$\ell_{eh,avg}$ in.	f_{cm} Psi	b^a in.	c_{so} in.	c_{th} in.	c_h in.	T lb	T_h lb	T/T_h	$f_{su,avg}$ psi	Failure Mode
Group 1 – No. 8 bars without confining reinforcement													
8-8-90-0-o-2.5-2-8	A	8.6	8.5	8740	17	2.8	1.8	9.0	33000	44255	0.75	41800	S/TK
	B	8.3				2.5	2.1						S/TK
8-8-90-0-o-3.5-2-8	A	7.6	7.8	8810	19	3.5	2.4	9.8	35900	40883	0.88	45400	F/S
	B	8.0				3.6	2.0						S/F
8-8-90-0-o-4-2-8	A	8.1	8.2	8630	20	4.5	2.5	9.8	37500	42709	0.88	47500	S/F
	B	8.3				3.8	2.4						S
8-8-90-0-i-2.5-2-8	A	8.0	8.0	8780	17	2.8	2.8	9.5	36800	41882	0.88	46600	F/S
	B	8.0				2.8	2.8						F/S
8-8-90-0-i-3.5-2-8	A	8.5	8.3	8780	19	3.6	2.1	10.0	42000	43271	0.97	53200	F
	B	8.0				3.8	2.6						F
8-8-90-0-i-4-2-8	A	7.6	7.8	8740	20	4.5	2.9	9.5	37400	40788	0.92	47400	F/S
	B	8.0				3.9	2.5						F
Group 2– No. 8 bars with 5 No. 3 hoops as confining reinforcement													
8-5-90-5#3-o-2.5-2-10a	A	10.3	10.4	5270	17	2.6	1.8	9.9	54300	64329	0.84	68700	S
	B	10.5				2.6	2.0						S
8-5-90-5#3-o-2.5-2-10b	A	10.5	10.5	5440	17	2.5	2.0	9.9	65600	65382	1.00	83000	F/S
	B	10.5				2.6	2.0						S/F
8-5-90-5#3-o-2.5-2-10c	A	11.3	10.9	5650	17	2.6	1.3	9.9	57700	67783	0.85	73000	S/F
	B	10.5				2.5	2.0						S/F
8-5-90-5#3-i-2.5-2-10a	B	10.5	10.5	5270	17	2.5	1.8	9.8	82800	64937	1.28	104800	F/S
8-5-90-5#3-i-2.5-2-10b	A	10.3	10.4	5440	17	2.8	2.0	9.9	69700	64769	1.08	88200	F/S
	B	10.5				2.6	1.8						F
8-5-90-5#3-i-2.5-2-10c	A	10.5	10.5	5650	17	2.5	2.0	10.0	68800	65920	1.04	87100	F/S
	B	10.5				2.5	2.0						F/S
Group 3– No. 11 bars without confining reinforcement													
11-12-180-0-o-2.5-2-17*	A	16.9	17.1	11800	21.5	2.5	2.3	13.4	83500	122610	0.68	53500	S/F
	B	17.3				2.6	1.9						S
11-12-90-0-o-2.5-2-17	A	17.1	16.9	11800	21.5	2.5	2.2	13.8	105400	121183	0.87	67600	F/TK
	B	16.6				2.5	2.7						F/TK
11-12-180-0-i-2.5-2-17*	A	16.6	16.6	11880	21.5	3.0	2.5	13.3	107500	119514	0.90	68900	S/F
	B	16.6				2.5	2.5						S
11-12-90-0-i-2.5-2-17	A	16.1	16.5	11880	21.5	2.5	3.1	13.3	119700	118562	1.01	76700	S
	B	16.9				2.6	2.4						S/F
Group 4– No. 11 bars with 6 No. 3 hoops as confining reinforcement													
11-12-180-6#3-o-2.5-2-17*	A	16.6	16.5	11800	21.5	2.5	2.9	13.5	113100	138845	0.81	72500	S
	B	16.4				2.8	3.1						F/S
11-12-90-6#3-o-2.5-2-17	A	15.6	16.5	11800	21.5	2.5	3.6	13.8	115900	138370	0.84	74300	F/S
	B	17.3				2.4	2.0						S/F
11-12-180-6#3-i-2.5-2-17a*	A	16.9	16.7	12370	21.5	2.6	2.9	13.5	116400	141920	0.82	74600	F
	B	16.5				2.8	3.3						F/S
11-12-180-6#3-i-2.5-2-17b*	A	16.8	16.8	12370	21.5	2.5	2.7	13.4	148700	142643	1.04	95300	F/S
	B	16.8				2.8	2.6						S/F
11-12-90-6#3-i-2.5-2-17	A	17.1	16.8	12370	21.5	2.6	1.9	13.0	161600	142884	1.13	103600	F/S
	B	16.5				3.0	2.6						S/S

^a Nominal depth of specimen is found by adding the nominal tail cover to the nominal embedment length.

* Hook bend angle is 180°

Note: 1 in. = 25.4 mm, 1 ksi = 6.89 MPa, 1 lb = 4.45 N

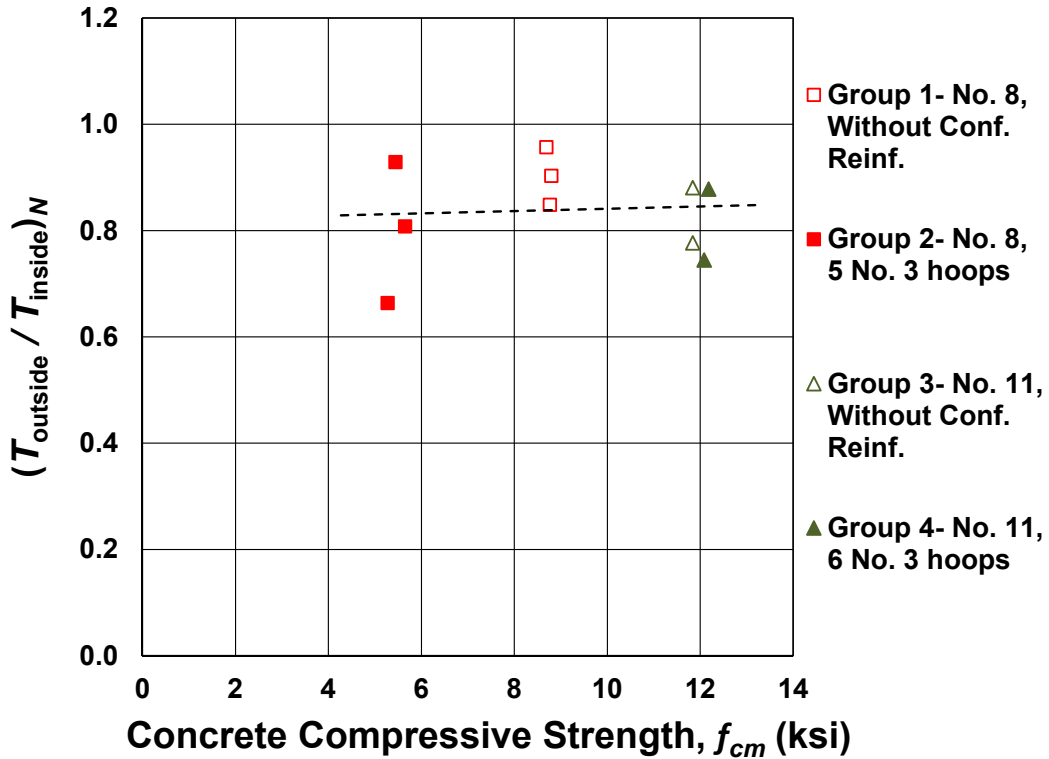

Figure 3.6 Ratio $(T_{outside}/T_{inside})_N$ for specimens with hooked bars inside and outside the column core (specimens listed in Table 3.5)

Figure 3.7 shows the average stresses at failure for the hooked bars in the four groups shown in Table 3.5. Like the results in Figure 3.6, the results are normalized using the same logic to eliminate the effect of differences in concrete compressive strength and embedment length for the companion specimens. Strength normalization is achieved by multiplying the anchorage strength with $(5000/f_{cm})^{0.29} \times (10/\ell_{eh})^{1.06}$, converting the results to an equivalent anchorage strength for $f_{cm} = 5000$ psi and $\ell_{eh} = 10$ in. All groups showed consistently lower strength for the specimens with hooked bars placed outside the column core compared to the companion specimens with hooked bars placed inside the column core.

For the specimens in Group 1 (No. 8 [No. 25] hooked bars without confining reinforcement), the average normalized stress at failure for hooked bars inside the column core

was 52,600 psi (363 MPa) compared to 47,600 psi (328 MPa) for the hooked bars placed outside the column core. For the specimens in Group 2 (No. 8 [No. 25] hooked bars confined by 5 No. 3 [No. 10] hoops spaced at $3d_b$), the average stress at failure for hooked bars inside the column core was 86,900 psi (599 MPa) compared to 68,800 psi (474 MPa) for the hooked bars placed outside the column core. For the specimens in Group 3 (No. 11 [No. 36] hooked bars without confining reinforcement), the average stress at failure was 33,200 psi (229 MPa) for the hooked bars placed inside the column core, compared to 27,000 psi (186 MPa) for the hooked bars placed outside the column core. For the specimens in Group 4 (No. 11 [No. 36] hooked bars confined with 6 No. 3 [No. 10] hoops spaced at $3d_b$), the average stress at failure was 40,500 psi (279 MPa) for the hooked bars placed inside the column core, compared to 33,700 psi (232 MPa) for the hooked bars placed outside the column core. The specimens with hooked bars placed outside the column core had consistently lower stresses at failure when compared to companion specimens with hooked bars placed inside the column core, with average decreases of 11, 26, 23, and 20 % for specimens in Groups 1, 2, 3 and 4, respectively.

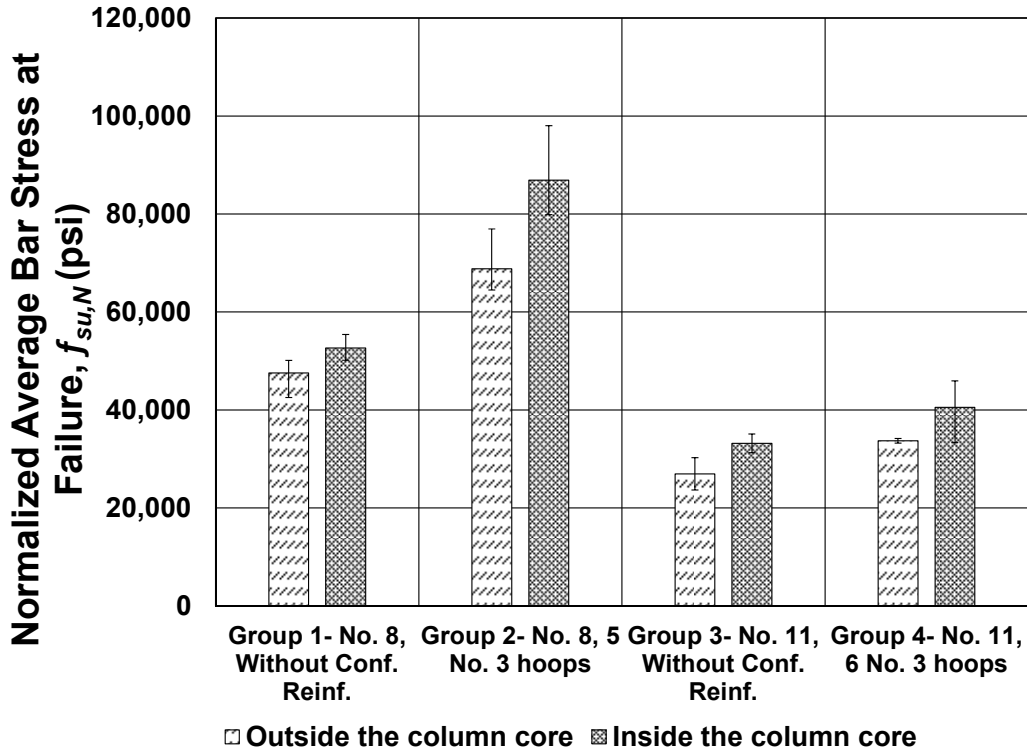

Figure 3.7 Inside versus outside the column core comparison for specimens in Groups 1 to 4 in Table 3.5

Figure 3.8 shows the percentage of hooked bars exhibiting front and side failure as a function of hook location for the specimens in Table 3.5. As observed by Sperry et al. (2017a) and described in Chapter 2, front failure was dominant (71 percent versus 29 percent for side failure) for hooked bars placed inside the column core. As shown in Figure, 3.8, however, side failure was clearly dominant (70 percent versus 30 percent for front failure) for hooked bars placed outside the column core.

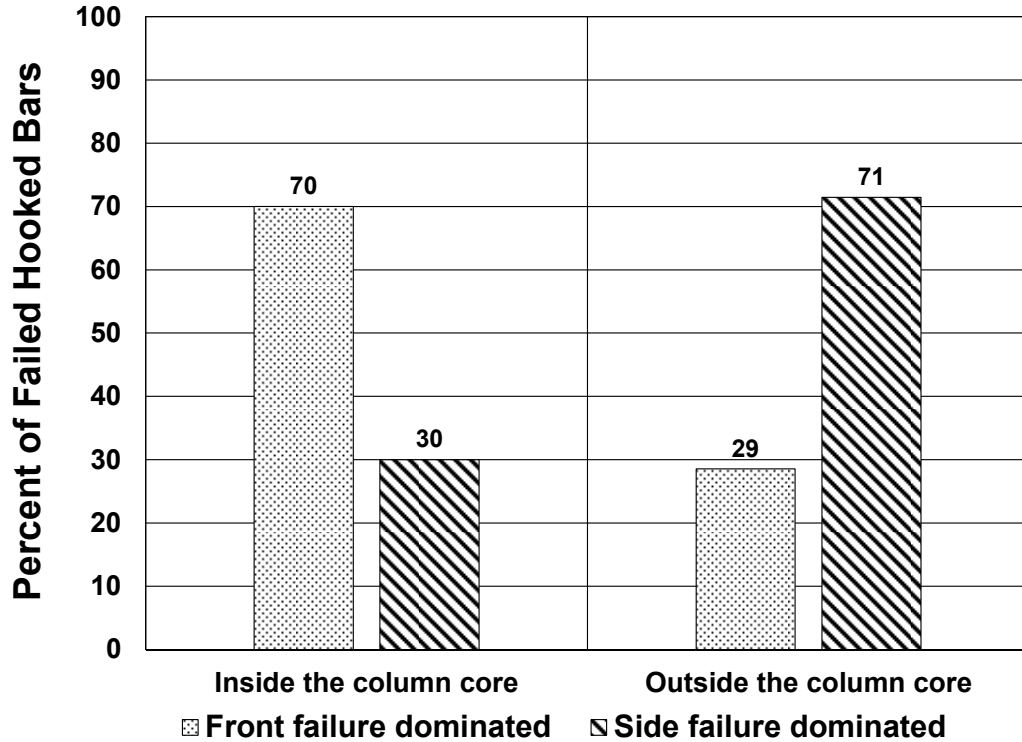

Figure 3.8 Dominant mode of failure for specimens with hooked bars placed inside vs outside the column core in Table 3.5

3.4.2.2 Comparison of hooked bars placed inside and outside column core for all concrete batches

Measured average anchorage strengths for specimens with hooked bars cast inside and outside the column core are compared with anchorage strengths calculated using Eq. (3.2). The equation was developed by Sperry et al. (2015b) using results from specimens with two widely-spaced hooked bars placed inside the column core:

$$T_h = 332 f_{cm}^{0.29} \ell_{eh}^{1.06} d_b^{0.54} + 54,250 \left(\frac{NA_{tr}}{n} \right)^{1.06} d_b^{0.59} \quad (3.2)$$

where T_h is the force in hooked bar at failure (lb), f_{cm} is the measured concrete compressive strength using 6×12 in. (150×300 mm) standard cylinders at the time of test (psi), ℓ_{eh} is the hooked bar embedment length (in.), d_b is the bar diameter (in.), N is the total number of legs confining the hooked bars in the joint, A_{tr} is the area of single leg of confining reinforcement (in^2), and n is the

number of hooked bars in the joint confined by N legs of confining reinforcement. Equation (3.1) has mean test-to-calculated strength ratio T/T_h of 1.0 for both specimens without and with confining reinforcement. For specimens without and with confining reinforcement, the coefficients of variation are 0.119 and 0.112, the minimum test-to-calculated strength ratios are 0.73 and 0.68, and the maximum test-to-calculated strength ratios are 1.29 and 1.28, respectively.

The specimens are categorized based on hooked bar size and then subdivided into specimens without confining reinforcement, with two No. 3 (No. 10) hoops, and with No. 3 (No. 10) hoops spaced at $3d_b$ at the joint region. The test-to-calculated strength ratios T/T_h are obtained and compared for specimens with two hooked bars.

Table 3.6 summarizes the specimens used in the analysis and shows the mean, standard deviation STD, and the coefficient of variation COV of test-to-calculated strength ratio for the specimens in each group. Specimen details are presented in Appendix B. The results for the three bar sizes are evaluated individually.

Table 3.6 Statistical parameters of T/T_h for hooked bars inside and outside the column core with T_h based on Eq. (3.2)

Confining Reinforcement		None		2 No. 3 (No. 10)		No. 3 (No. 10) @ $3d_b$	
		Outside core	Inside core	Outside core	Inside core	Outside core	Inside core
No. 5 (No. 16)	Mean	0.92	1.02	0.93	1.02	0.69	0.97
	STD	0.13	0.09	0.23	0.18	0.07	0.06
	COV	0.14	0.09	0.25	0.17	0.10	0.06
	No. of Specimens	8	19	4	16	5	6
No. 8 (No. 25)	Mean	0.88	1.01	---	---	0.90	0.99
	STD	0.14	0.14	---	---	0.14	0.09
	COV	0.16	0.14	---	---	0.15	0.09
	No. of Specimens	6	36	0	0	6	31
No. 11 (No. 36)	Mean	0.88	0.96	---	---	0.93	1.00
	STD	0.14	0.12	---	---	0.12	0.10
	COV	0.16	0.12	---	---	0.13	0.10
	No. of Specimens	4	17	0	0	4	18

The first comparison includes 58 No. 5 (No. 16) hooked bar specimens, 17 with hooked bars outside the column core and 41 with hooked bars inside the column core. Average stresses at anchorage failure ranged from 45,400 to 141,600 psi (313 to 977 MPa), and concrete compressive strengths ranged from 4,420 to 15,800 psi (30 to 109 MPa). For specimens without confining reinforcement, two No. 3 (No. 10), and five No. 3 (No. 10) hoops spaced at $3d_b$ respectively, the average values of T/T_h with T_h based on Eq. (3.2) are 0.92, 0.93, and 0.69 for specimens with hooked bars placed outside the column core compared to 1.02, 1.10, and 0.97 for specimens with hooked bars placed inside the column core. The results show that placing the hooked bars outside the column core resulted in lower anchorage strength than placing the hooked bars inside the column core and that the specimens with hooked bars placed outside the column core confined by No. 3 (No. 10) hoops spaced at $3d_b$ had a very low test-to-calculate strength ratio when compared to hooked bars placed inside the column core.

The second comparison includes 79 No. 8 (No. 25) hooked bar specimens, 12 with hooked bars outside the column core and 67 with hooked bars inside the column core. Average stresses at failure in the hooked bars ranged from 41,800 to 120,700 psi (288 MPa to 832 MPa), and concrete compressive strengths ranged from 4,490 psi to 16,150 psi (31 MPa to 111 MPa). For specimens with hooked bars placed outside the column core, the average values of T/T_h are 0.88 and 0.90 for specimens without confining reinforcement and with No. 3 (No. 10) hoops spaced at $3d_b$ within the joint region, respectively. While for specimens with hooked bars placed inside the column core, the average values of T/T_h are 1.01 and 0.99 for specimens without confining reinforcement and with No. 3 (No. 10) hoops spaced at $3d_b$ within the joint region, respectively. In this case, the

negative effects of placing the hooked bars outside the column core were about the same without and with confining reinforcement.

The third comparison includes 43 specimens containing No. 11 (No. 36) hooked bars, 8 with hooked bars outside the column core and 35 with hooked bars inside the column core. Average stresses at failure in the hooked bars ranged from 33,000 to 136,700 psi (228 MPa to 943 MPa), and concrete compressive strengths ranged from 4,910 psi to 16,180 psi (34 MPa to 112 MPa). For specimens with hooked bars placed outside the column core, the average values of T/T_h are 0.88, and 0.93 for specimens without confining reinforcement and with No. 3 (No. 10) hoops spaced at $3d_b$ within the joint region, respectively. While for specimens with hooked bars placed inside the column core, the average values of T/T_h are 0.96, and 1.00 for specimens without confining reinforcement and with No. 3 (No. 10) hoops spaced at $3d_b$ within the joint region, respectively. As for the smaller size bars, placing the hooked bars outside the column core results in lower anchorage strengths than placing the hooked bars inside the column core. In this case, providing confining reinforcement, slightly reduced the negative impact of anchoring the hooked bars outside of the column core.

Overall, when hooked bars were placed outside column core, with the exception of the No. 5 (No. 16) bars confined by No. 3 (No. 10) hoops spaced at $3d_b$, for a given hooked bar size, the average test-to-calculated strength ratio T/T_h increased with confining reinforcement, where T_h is based on Eq. (3.2).

Figure 3.9 shows the percent of hooked bars exhibiting front and side failure modes as a function of bar size (No. 5, 8, and 11 [No. 16, 25, and 36]) for hooked bars placed inside and outside the column core in Table 3.6. The figure shows that when hooked bars are placed inside

the column core, the dominant failure mode is front failure for all bar sizes, although the percentage of bars exhibiting front failure decreases as the bar size increases. As observed by (Sperry et al. 2015b), the percentage of side failures increases with increasing bar size occurs because the majority of specimens had the same side cover (2.5 in. [64 mm]), resulting in a smaller ratio of cover-to-bar diameter as the bar size increases. For specimens with hooked bars placed outside column core, the dominant failure mode was front failure for No. 5 (No. 16) bars while the dominant failure mode was side failure for No. 8 and No. 11 (No. 25 and No. 36) hooked bars.

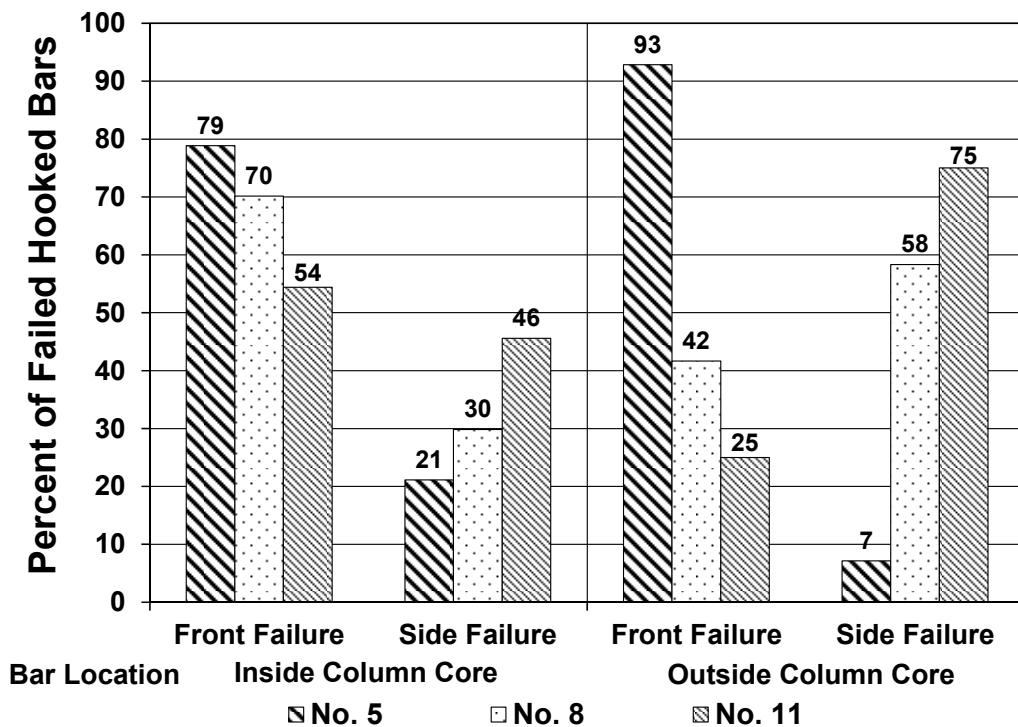

Figure 3.9 Percent of hooked bars exhibiting front or side failure for specimens in Table 3.6 as a function of bar size and hooked bar location

Figure 3.10 shows the failure modes of specimens in Table 3.6 based on the absence or presence of confining reinforcement within the joint region. Front failure is the dominant failure mode for both bar placements, but is more likely to occur for specimens with confining reinforcement or for hooked bars inside the column core. The likelihood of a side failure increases

when the hooked bar is placed outside the column core and when no confining reinforcement is provided in the joint region.

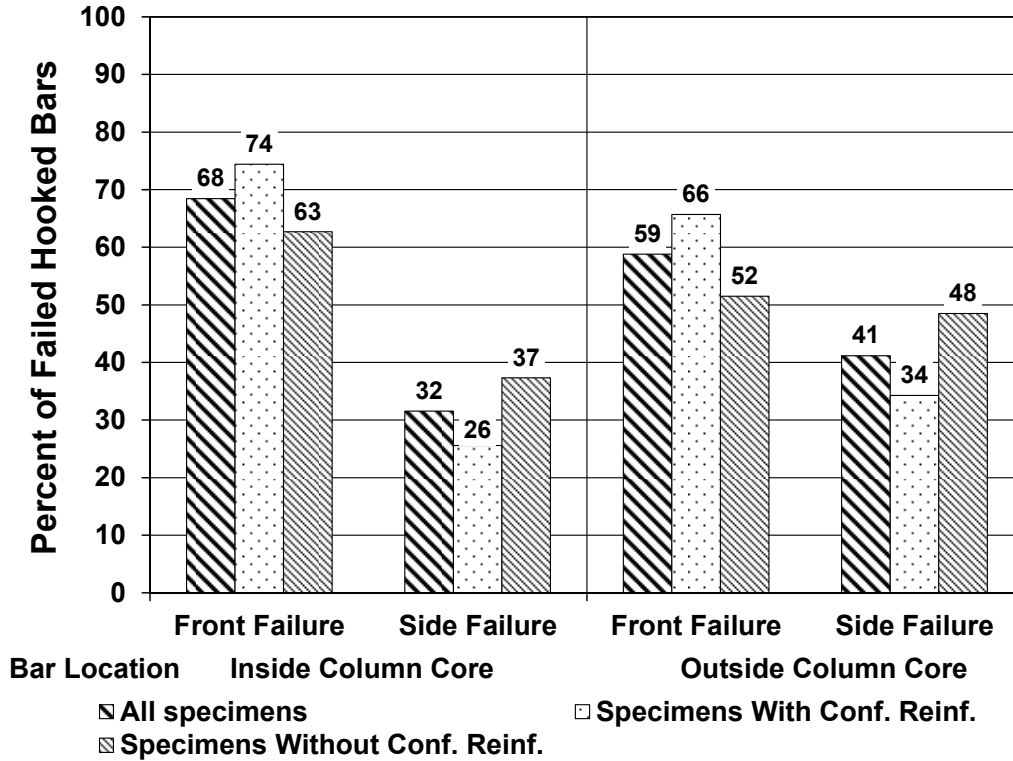

Figure 3.10 Percent of hooked bars exhibiting front or side failure for specimens in Table 3.6 based on the absence or presence of confining reinforcement and hooked bar location

3.4.3 Effect of hooked bar position within the column depth

To study the effect of hooked bar position on anchorage strength, hooked bars were extended just halfway through the column depth in 24 specimens, 10 with two hooked bars, eight with three hooked bars, and six with four hooked bars. The anchorage strength of these specimens will be compared with the strength calculated using Eq. (3.2), which was derived for specimens with widely-spaced hooked bars extended to the far face of the column.

Table 3.7 provides the details of the 10 specimens that contained two hooked bars, including test-to-calculated strength ratios T/T_h obtained using Eq. (3.2). Concrete compressive

strengths ranged from 5280 to 7,710 psi (36 to 53 MPa), and the stresses in the hooked bars at failure ranged from 38,600 to 80,100 psi (266 to 552 MPa).

Table 3.7 Specimens with hooked bars extended halfway through the column depth (all hooked bars exhibited front failure)^a

Specimen	Hook	l_{eh} in.	$l_{eh,avg}$ in.	f_{cm} psi	b^b in.	c_{so} in.	$c_{so,avg}$ in.	c_{th} in.	T lb	T/T_h
8-8-90-0-i-2.5sc-9tc-9	A B	9.3 9.0	9.1	7710	17.0	2.8 2.8	2.8	8.8 9.0	37700	0.81
(2@3) 8-8-90-0-i-2.5-9-9	A B	9.3 9.0	9.1	7510	9.0	2.5 2.6	2.6	8.8 9.0	30700	0.67
(2@4) 8-8-90-0-i-2.5-9-9	A B	9.9 10.0	9.9	7510	10.0	2.6 2.5	2.5	8.1 8.0	34200	0.68
8-8-90-5#3-i-2.5-9-9 [‡]	A B	9.0 9.3	9.1	7710	17.0	2.5 2.8	2.6	9.0 8.8	63290	1.00
(2@3) 8-8-90-5#3-i-2.5-9-9	A B	9.3 9.5	9.4	7440	9.0	2.5 2.5	2.5	8.8 8.5	58790	0.92
(2@4) 8-8-90-5#3-i-2.5-9-9	A B	8.9 9.1	9.0	7440	10.0	2.5 2.5	2.5	9.1 8.9	57450	0.93
(2@5.35) 11-5-90-0-i-2.5-13-13	A B	14.0 13.9	13.9	5330	14.0	2.6 2.6	2.6	12.0 12.1	60200	0.77
(2@5.35) 11-5-90-2#3-i-2.5-13-13	A B	13.9 13.8	13.8	5330	14.0	2.7 2.6	2.6	12.1 12.3	69100	0.89
(2@5.35) 11-5-90-6#3-i-2.5-13-13	A B	14.0 13.8	13.9	5280	14.0	2.4 2.8	2.6	12.0 12.3	89700	0.91
(2@5.35) 11-5-90-6#3-i-2.5-18-18	A B	19.3 19.5	19.4	5280	14.0	2.7 2.6	2.6	16.8 16.5	121600	0.92

^aAll hooked bars had 90° bend angle

^bNominal depth of specimen is found by adding the nominal tail cover to the nominal embedment length.

[‡]Specimen contained ASTM A1035 Grade 120 longitudinal reinforcement

Note: 1 in. = 25.4 mm, 1 ksi = 6.89 MPa, 1 lb = 4.45 N

For the 10 specimens in Table 3.7, T/T_h based on Eq. (3.2) ranges from 0.67 to 1.0, with nine below 1.0. It is hypothesized that the reduction in anchorage strength was due to the hooked bar being located outside the column compression region where the concrete is more likely to exhibit flexural or tensile cracking, which may reduce the anchorage strength of the embedded bar. The average test-to-calculated strength ratio T/T_h is 0.73 for specimens without confining reinforcement compared to 0.93 for specimens with confining reinforcement, suggesting that confining reinforcement mitigates this effect. The overall average is 0.85. The effect of confining reinforcement could be related to failure mode. All specimens exhibited front failure, and the

placement of confining reinforcement parallel to the hooked bar makes the hoops work as anchors to prevent the mass of concrete being pulled out with the bar.

Table 3.8 shows the details for the specimens with three or four closely-spaced hooked bars, T_h is calculated using Eq. (2.7) from Chapter 2, which accounts for the effect of closely-spaced hooked bars.

$$T_h = \left[332 f_{cm}^{0.29} \ell_{eh}^{1.06} d_b^{0.54} + 54,250 \left(\frac{NA_r}{n} \right)^{1.06} d_b^{0.59} \right] \omega_s \quad (3.3)$$

where

$$\omega_s = \frac{NA_r/n}{0.22} \left[\left(0.035 \frac{c_{ch}}{d_b} + 0.74 \right) - \left(0.085 \frac{c_{ch}}{d_b} + 0.422 \right) \right] + \left(0.085 \frac{c_{ch}}{d_b} + 0.422 \right) \quad (3.4)$$

where c_{ch} represents the center-to-center spacing between hooked bars (in.) and d_b is the hooked bar diameter (in.).

Concrete compressive strengths ranging from 5280 to 7,510 psi (36 to 52 MPa), and stresses in hooked bars at failure ranged from 22,800 to 100,700 psi (157 to 694 MPa). Most of the specimens exhibited a low test-to-calculated strength ratio compared to specimens with hooked bars extended to the far side of the column.

Table 3.8 Specimens with multiple hooked bars extended halfway through the column depth^a

Specimen	Hook	l_{eh} in.	$l_{eh,avg}$ in.	f_{cm} psi	b^b in.	c_{so} in.	$c_{so,avg}$ in.	c_{th} in.	N_h	T lb	Failure Mode	T/T_h^c
(4@6) 5-8-90-0-i-2.5-6-6	A	6.3	6.3	6690	17.0	2.5	2.6	5.8	4	16100	F/S	0.77
	B	6.3				6.3		5.8			F/S	
	C	6.3				6.5		5.8			F/S	
	D	6.3				2.7		5.8			F/S	
(4@6) 5-8-90-5#3-i-2.5-6-6 [‡]	A	6.8	6.4	6690	17.0	2.5	2.6	5.3	4	31200	F	1.10
	B	6.0				6.5		6.0			F	
	C	6.5				6.5		5.5			F	
	D	6.3				2.7		5.8			F	
(3@3) 8-8-90-0-i-2.5-9-9	A	9.5	9.4	7510	12.0	2.5	2.5	8.5	3	21400	F	0.69
	B	9.5				5.6		8.5			F	
	C	9.3				2.5		8.8			F	
(3@4) 8-8-90-0-i-2.5-9-9	A	9.3	9.3	7510	14.0	2.5	2.5	8.8	3	26400	F	0.76
	B	9.3				6.5		8.8			F	
	C	9.3				2.5		8.8			F	
(4@3) 8-8-90-0-i-2.5-9-9	A	9.4	9.4	7510	15.0	2.5	2.5	8.6	3	18700	F	0.67
	B	9.3				5.5		8.8			F	
	C	9.3				5.5		8.8			F	
	D	9.6				2.5		8.4			F	
(4@4) 8-8-90-0-i-2.5-9-9	A	9.4	9.2	7510	18.0	2.5	2.5	8.6	3	18000	F	0.57
	B	9.1				6.6		8.9			F	
	C	9.0				6.5		9.0			F	
	D	9.1				2.5		8.9			F	
(3@3) 8-8-90-5#3-i-2.5-9-9	A	9.5	9.3	7440	12.0	2.5	2.5	8.5	3	39800	F	0.77
	B	9.0				5.5		9.0			F	
	C	9.5				2.5		8.5			F	
(3@4) 8-8-90-5#3-i-2.5-9-9	A	8.9	9.1	7440	14.0	2.5	2.5	9.1	3	36600	F	0.70
	B	9.1				6.5		8.9			F	
	C	9.3				2.5		8.8			F	
(4@3) 8-8-90-5#3-i-2.5-9-9	A	9.3	9.3	7440	15.0	2.5	2.5	8.8	4	31400	F	0.78
	B	9.3				5.5		8.8			F	
	C	9.3				5.5		8.8			F	
	D	9.3				2.5		8.8			F	
(4@4) 8-8-90-5#3-i-2.5-9-9	A	9.5	9.5	7440	18.0	2.5	2.5	8.5	4	29500	F	0.72
	B	9.5				6.5		8.5			F	
	C	9.3				6.5		8.8			F	
	D	9.6				2.5		8.4			F	
(3@5.35) 11-5-90-0-i-2.5-13-13	A	13.8	13.8	5330	21.5	2.6	2.6	12.3	3	51500	F	0.78
	B	14.3				10.0		11.8			F	
	C	13.5				2.6		12.5			F	
(3@5.35) 11-5-90-2#3-i-2.5-13-13	A	14.0	13.9	5330	21.5	2.6	2.6	12.0	3	57900	F	0.79
	B	14.0				10.0		12.0			F	
	C	13.8				2.6		12.3			F	
(3@5.35) 11-5-90-6#3-i-2.5-13-13	A	13.5	13.6	5280	21.5	2.6	2.6	12.5	3	66200	F	0.77
	B	13.5				10.0		12.5			F	
	C	13.8				2.7		12.3			F	
(3@5.35) 11-5-90-6#3-i-2.5-18-18	A	18.6	18.6	5280	21.5	2.5	2.7	17.4	3	111900	F	0.97
	B	18.6				10.0		17.4			F	
	C	18.6				2.8		17.4			F	

^a All hooked bars had 90° bend angle

^b Nominal depth of specimen is found by adding the nominal tail cover to the nominal embedment length.

^c T_h based on Eq. (3.3)

[‡] Specimen contained ASTM A1035 Grade 120 longitudinal reinforcement

For the 14 specimens in Table 3.8, T/T_h ranges from 0.57 to 1.10, with 13 specimens below 1.0. Table 3.8 shows that front failure is the dominant failure mode for all specimens; just one specimen exhibited side failure, and even in that case, it was coupled with a front failure. The

average test-to-calculated strength ratio is 0.71 for specimens without confining reinforcement compared to 0.83 for specimens with confining reinforcement, again indicating that confining reinforcement mitigates this effect, as observed for specimens with two hooked bars. The overall average value is 0.77. The behavior is, in general, similar to that of the specimens containing two hooked bars. Like those specimens, it is hypothesized that the low relative anchorage strengths of hooked bars not extended to the far side of the column may be due to tensile stresses (or lower compressive stresses) within the middle of the column or due to a breakout failure, as discussed in the next section.

3.4.4 Effect of the effective depth to embedment length ratio d_{eff}/ℓ_{eh} ratio on hooked bar anchorage strength

Section R25.4.4.2 of the Commentary on the ACI 318-14 headed bar design provisions recommends that confining reinforcement in the form of hoops be provided when the development length of headed bars anchored in a beam-column joint is less than $d/1.5$ to prevent concrete breakout failure, where d is the effective depth of the beam. The current test results show that all specimens with hooked bars extended halfway through the column depth exhibited front failure, equivalent to a concrete breakout failure, and were weaker than specimens in which the hooked bars are extended to the back of the column.

The distance between the centroid of the bars in tension and the effective location of the compression face of the member d in a simulated beam-column joint can be calculated using the strength design method for concrete members in flexure. The value of d for the beam-column joint specimens could be taken as the sum of the distance from the center of the hooked bar to the bearing member plate h_{cl} and the height of the bearing plate (Figures 3.4a and b). The failure modes of the specimens, however, indicate that the compressive force is concentrated at the top of the

bearing plate, suggesting that using the total height of bearing plate will overestimate the value of d . Alternatively, an effective value of d , d_{eff} can be calculated using h_{cl} plus the distance c from the effective extreme compressive fiber of the beam to the neutral axis, taken at the top of the bearing plate c . In this analysis, c is based on the depth of the concrete compression stress block a calculated using strength design for flexural members. Figure 3.11 shows the concrete compression block acting on part of the bearing member plate. The effective depth equals

$$d_{eff} = h_{cl} + c \quad (3.5)$$

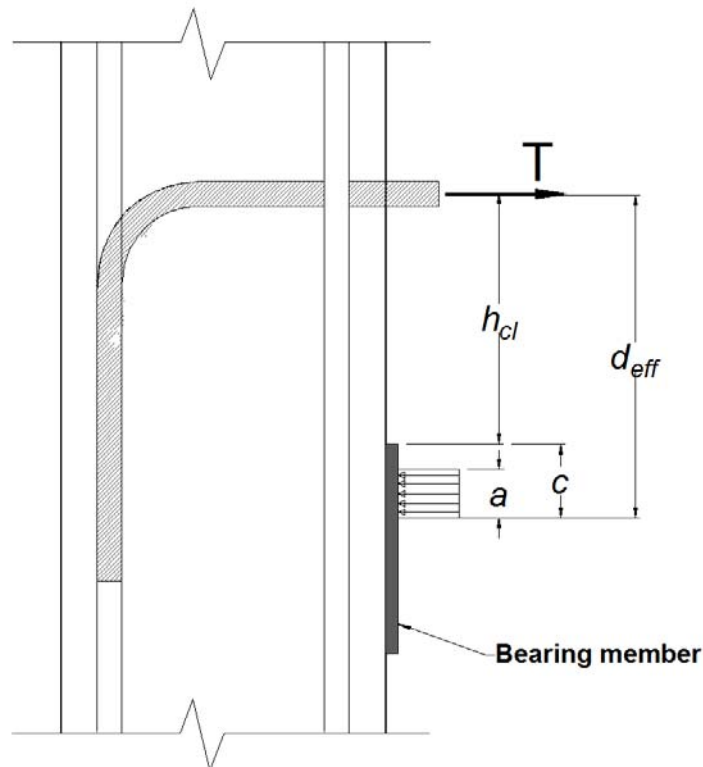

Figure 3.11 Representation of effective depth d_{eff} and compression stress block

The value of c is calculated from

$$c = a/\beta_1 \quad (3.6)$$

where a is calculated using the total force applied to the joint at failure T_{total} , which, based on equilibrium, equals to the compressive force in the concrete compression block. The values of T_{total} can be found in Appendix B, and a is calculated using the equation

$$a = \frac{T_{total}}{0.85 f_{cm} b} \quad (3.7)$$

where b is the width of the beam in the beam-column joint (in.).

β_1 is the factor relating the depth of equivalent compressive stress block a to depth of neutral axis c , as described in Section 22.2.2.4.3 of ACI 318-14, and is calculated using Eq. (3.8).

$$\beta_1 = 0.85 - \frac{0.05(f_{cm} - 4000)}{1000} \geq 0.65 \quad (3.8)$$

Figures 3.12a and b compare T/T_h versus d_{eff}/ℓ_{eh} for the specimens in Tables 3.7 and 3.8, specimens without and with confining reinforcement, respectively, where T_h is based on Eq. (3.3). The figures show a reduction in the test-to-calculated strength ratio when the value of d_{eff}/ℓ_{eh} is above 1.5, which coincides with the ratio presented in Commentary R25.4.4.2 of ACI 318-14. In addition, the figures show a reduction in the test-to-calculated strength for specimens with hooked bars not extended to the back of the column with d_{eff}/ℓ_{eh} less than 1.5 for specimens both without and with confining reinforcement.

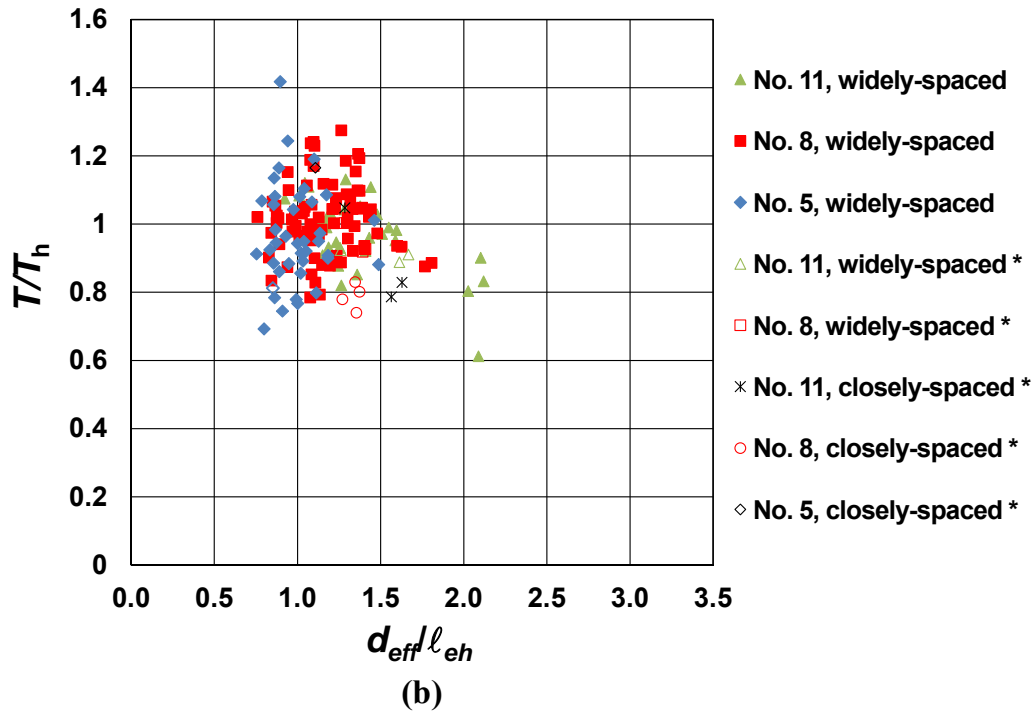
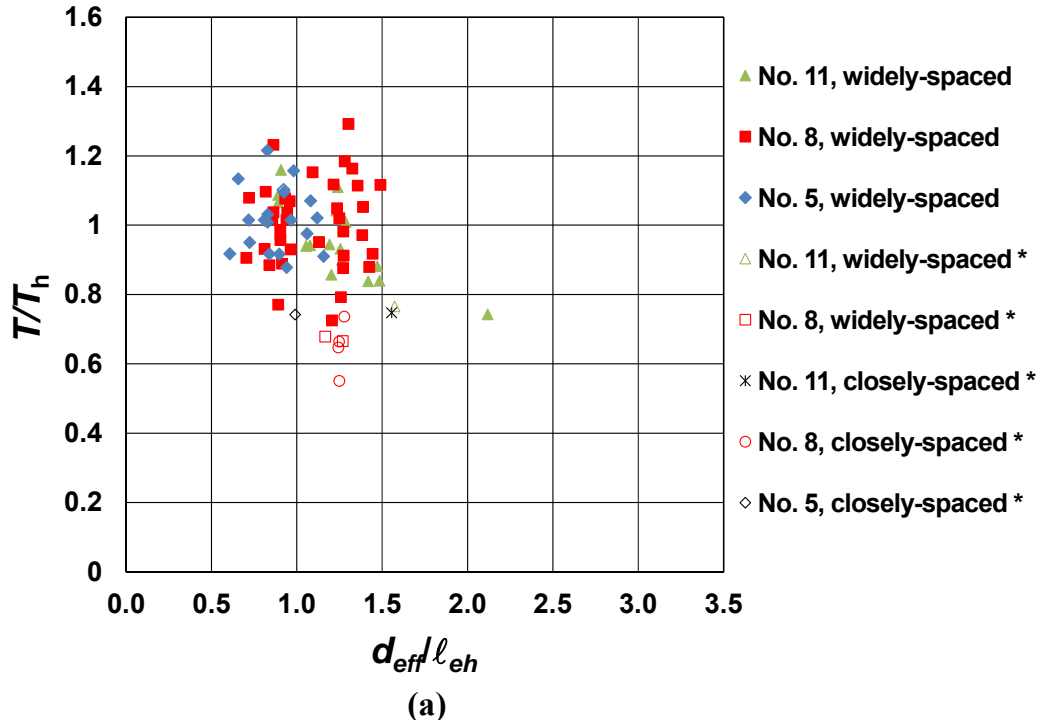

* Specimens with hooked bars not extended to the back of the column

Figure 3.12 T/T_c and T/T_h versus d_{eff}/l_{eh} for closely-spaced hooked bar specimens (a) without and (b) with confining reinforcement in Tables 3.7 and 3.8 and widely-spaced hooked bar specimens in Appendix B

Figures 3.12 a and b show that for specimens with two widely-spaced hooked bars, there is a noticeable reduction in the test-to-calculated strength ratio T/T_h when increasing the ratio of d_{eff}/ℓ_{eh} . At the same time, for specimens extended halfway through the column depth, the figures show a reduction in the test-to-calculated strength ratio when d_{eff}/ℓ_{eh} is less than 1.5. This implies that the reduction in strength can be due to both the lack of compressive stresses near the hook and the ratio of d_{eff}/ℓ_{eh} .

3.4.5 Effects of hooked bar tail cover and tail kickout

This section examines the effect of tail cover less than the 2 in. (50 mm) minimum required by Section 25.4.3.2 of ACI 318-14 hooked bar design provisions to apply the 0.7 modification factor to the development length of hooks with a 90° bend angle. In addition to a tail cover of 2 in. (50 mm), Section 25.4.3.2 of ACI 318-14 requires a minimum side cover of 2.5 in. (64 mm) for both 90° and 180° hooks. These requirements are based on the design recommendations by Marques and Jirsa (Jirsa and Marques 1972, Marques and Jirsa 1975). Their results show that when adequate concrete cover is provided, the anchorage strength of a hooked bar is increased. Although not mentioned by Jirsa and Marques (1972) or Marques and Jirsa (1975), Marques (1973) stated that when cover increases, the likelihood of a sudden brittle failure decreases.

With the exception of the hooked bars embedded halfway through the column depth described in the previous section, the specimens examined in this section had hooked bars with 90° hook bend angle and a nominal tail cover of 2 in. (50 mm). Actual tail covers, however, varied, providing an opportunity to determine the effect of tail cover less than 2 in. (50 mm) on anchorage strength of 90° hooks. This comparison is based on the 208 specimens in this study that contained two hooked bars, 180 with hooked bars placed inside the column core and 28 with hooked bars

placed outside the column core. In terms of individual hooked bars, a total of 399 hooked bars were analyzed, 347 inside the column core and 52 outside the column core (some specimens had usable data for only one of the two hooks). Since the actual cover may vary for hooked bars in the same specimen, the *peak load on the individual* hooked bar at failure T_{ind} in addition to the *average peak load* on hooked bars T is used when analyzing the effect of tail cover on anchorage strength. This differs from the previous analyses where only the average peak load on hooked bars T , obtained by dividing the maximum load on a group of hooked bars by the number of bars, is used. The average values of T_{ind}/T_h for the specimens containing two hooked bars without and with confining reinforcement *inside* the column core used to develop Eq. (3.2) are 1.05 and 1.04, respectively, compared to a value of 1.0 for T/T_h for specimens both without and with confining reinforcement. For specimens with hooked bars placed *outside* the column core, the average test-to-calculated strength ratios T_{ind}/T_h are 0.99 and 0.89 for specimens without and with confining reinforcement, respectively, compared to values of T/T_h of 0.90 and 0.84 for specimens without and with confining reinforcement obtained when using the average peak load T .

In the same specimen, the measured individual peak forces on hooked bars are different and hooked bars do not often reach their individual peak loads at the same time. The test-to-calculated strength ratios are usually higher when using the individual peak anchorage forces than when using the average peak force on the hooked bars unless all hooked bars in the specimen fail at the same time, resulting the same or close individual and average peak loads. After the failure of the first hooked bar, which usually has higher strength compared to the average strength, sometimes the other hooked bar does not pickup load and their individual load is lower than the average peak load. The above discussion explains why there are variations in the results when

using the peak load on individual hooked bar at failure T_{ind} compared to the average peak load on all hooked bars in a specimen T .

Figure 3.13 shows the distribution of the actual tail cover for the hooked bars in this study. Out of the 399 hooked bars with a bend angle of 90° , 129 had a tail cover below 2 in. (50 mm); of these, 116 were inside the column core, and 13 were outside the column core.

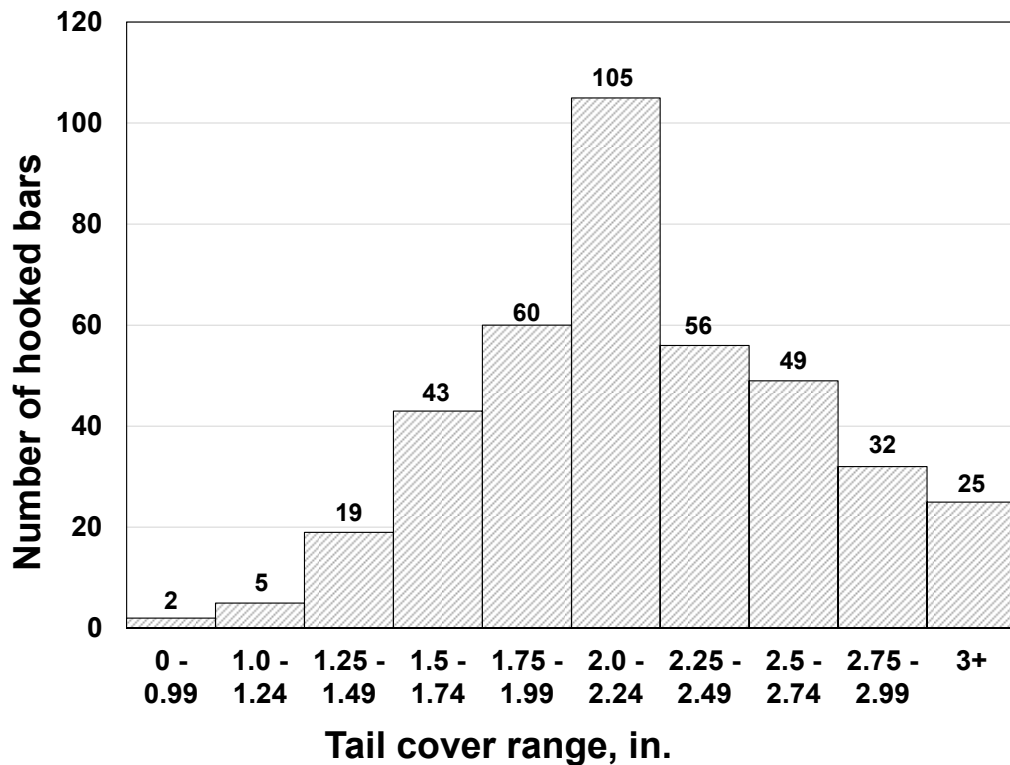

Figure 3.13 Tail cover distribution for hooked bars used in current study (1 in. = 25 mm)

Table 3.9 summarizes the number of hooked bars used in the analysis of the effect of tail cover and tail kickout on anchorage strength. The hooked bars are classified based on location (inside versus outside column core) and the confining reinforcement in the joint region (without and with confining reinforcement). The table shows the mean, standard deviation STD, and the coefficient of variation COV of the test-to-calculated strength ratio T_{ind}/T_h for the hooked bars in each group along with T/T_h for the specimens (in parenthesis) to evaluate the overall performance.

The comparison is based on the test-to-calculated strength ratios of hooked bars (specimens) with certain range of tail cover in a subset compared to the set that has the hooked bars (specimens) with all ranges of tail cover. Student's t-test is used to determine if the differences in values of T_{ind}/T_h and T/T_h are significant for hooked bars with specific tail cover compared to the average values of T_{ind}/T_h and T/T_h for the whole population. The parameter p from Student's t-test, also shown in Table 3.9, represents the probability that the difference in the mean value of the set under consideration and that of the whole population is due to random variations. Values of p smaller than a threshold value, indicate statistical differences. Sperry et al. (2015a) used p of 0.20 as the threshold for the Student's t-test due to the small datasets available. Because the current study is dealing with larger datasets, $p = 0.10$ is used as the threshold for the Student's t-test. Thus, values of p greater than 0.10 are taken as indicating that the difference is not statistically significant.

One of the hooked bars in Specimen 11-15-90-6#3-i-2.5-2-9.5 had a tail cover of 1.25 in. (31 mm) and a test-to-calculated strength ratio of 0.57. This specimen was not included in deriving Eq. (3.2) and is excluded from the current analysis.

Table 3.9 Statistical parameters of T_{ind}/T_h (T/T_h) for individual hooked bars and specimens inside and outside the column core with T_h based on Eq. (3.2)

Confining Reinforcement		Without confining reinforcement, hooked bars (specimens)*		With confining reinforcement, hooked bars (specimens)*	
		Outside core	Inside core	Outside core	Inside core
Hooked bars with tail cover <1.5 in. 26 hooked bars (22 specimens)	Mean	---	1.07 (1.00)	1.11 (0.90)	0.95 (0.94)
	STD	---	0.12 (0.10)	0.06 (0.07)	0.07 (0.09)
	COV	---	0.11 (0.10)	0.06 (0.08)	0.08 (0.09)
	p	---	0.37 (0.75)	0.04 (0.34)	0.015 (0.17)
	No. of hooked bars (Specimens)	0	18 (15)	2 (2)	6 (5)
Hooked bars with tail cover \geq1.5 and <2.0 in. 103 hooked bars (81 specimens)	Mean	1.05 (0.92)	1.02 (0.97)	0.87 (0.85)	1.06 (1.02)
	STD	0.13 (0.16)	0.17 (0.12)	0.15 (0.16)	0.13 (0.10)
	COV	0.12 (0.17)	0.17 (0.13)	0.17 (0.19)	0.12 (0.10)
	p	0.45 (0.90)	0.55 (0.52)	0.78 (0.79)	0.44 (0.37)
	No. of hooked bars (Specimens)	5 (4)	30 (21)	6 (5)	62 (51)
Hooked bars with tail cover <2 in. 129 hooked bars (94 specimens)	Mean	1.05 (0.92)	1.04 (0.99)	0.93 (0.85)	1.05 (1.02)
	STD	0.13 (0.16)	0.15 (0.12)	0.17 (0.14)	0.13 (0.10)
	COV	0.12 (0.17)	0.15 (0.12)	0.18 (0.17)	0.12 (0.10)
	p	0.45 (0.90)	0.94 (0.94)	0.56 (0.75)	0.83 (0.45)
	No. of hooked bars (Specimens)	5 (4)	48 (32)	8 (6)	68 (52)
Hooks with tail kickout 25 hooked bars (20 specimens)	Mean	0.95 (0.93)	1.05 (1.02)	---	0.97 (0.95)
	STD	0.12 (0.16)	0.12 (0.11)	---	0.05 (0.04)
	COV	0.12 (0.17)	0.11 (0.11)	---	0.05 (0.04)
	p	0.50 (0.87)	0.13 (0.51)	---	0.32 (0.12)
	No. of hooked bars (Specimens)	6 (4)	16 (13)	0	3 (3)

* Values outside of parenthesis represents individual hooked bars and inside parenthesis represents specimens.

Note: 1 in. = 25.4 mm.

Hooked bars with tail cover less than 1½ in. (40 mm): Based on Table 20.6.1.3.1 in ACI 318-14, the minimum cover that beams and columns can have when not exposed to weather or in contact with the ground is 1½ in. (40 mm). In this study, 26 hooked bars with a bend angle of 90° in 22 specimens had a tail cover less than 1½ in. (40 mm); 24 of these hooked bars were inside the column core, of which 18 did not have confining reinforcement and 6 did. Both of the specimens with hooked bars outside the column core had confining reinforcement. The average value of T_{ind}/T_h for the 18 hooked bars inside the column core without confining reinforcement is 1.07,

compared to 1.05 when all values of tail cover are considered, and 0.95 for the 6 hooked bars inside the column core with confining reinforcement, compared to 1.04 when all values of tail cover are considered. T_{ind}/T_h is 1.11 for the two hooked bars anchored outside the column core with confining reinforcement, compared to 0.89 when all values of tail cover are considered. Student's t-test shows that the differences in T_{ind}/T_h for hooked bars placed inside the column core without confining reinforcement is not significant with $p = 0.37$, while the differences are significant for hooked bars with confining reinforcement, outside and inside the column core, with $p = 0.04$ and 0.015, respectively. Hooked bars placed outside column core are expected to have lower test-to-calculated strength ratio compared to hooked bars placed inside column core, but the average T_{ind}/T_h value of 1.11 for the two hooked bars with confining reinforcement placed outside column core shows the opposite. Both hooked bars placed outside column core had higher strength than the other hooked bars in each specimen. When looking at the average anchorage strength for the specimens T/T_h for hooked bars with a tail cover less than 1½ in. (40 mm), Student's t-test results show that the differences in strengths, compared to specimens when all values of tail cover are considered, are not significant with all with p above 0.10. Overall, tail cover below 1½ in. did not influence anchorage strength.

Hooked bars with tail cover less than 2 in. (50 mm): In the current study, a total of 129 hooked bars in 94 specimens had a tail cover less than 2 in. (50 mm); 116 were inside the column core, 48 without confining reinforcement and 68 with confining reinforcement; and 13 were outside the column core, 5 without confining reinforcement and 8 with confining reinforcement. The average values of T_{ind}/T_h are 1.04 and 1.05, respectively, for hooked bars with tail cover less than 2 in. (50 mm) placed inside the column core without and with confining reinforcement,

virtually identical to the values of 1.05 and 1.04 for all test hooked bars. For hooked bars with tail cover less than 2 in. (50 mm) placed outside the column core, the values of T_{ind}/T_h are 1.05 and 0.93, respectively, for hooked bars without and with confining reinforcement compared to 0.99 and 0.89 for all hooked bars placed outside the column core. The values of p from Student's t-test are above 0.10 for these specimens, indicating that the differences in tail cover less than 2 in. (50 mm) did not affect anchorage strength.

Hooked bars and specimens containing hooked bars with tail cover greater than or equal to 1½ in. (40 mm) and less than 2 in. (50 mm) are also addressed in Table 3.9. When considering individual hooked bars or specimens, Student's t-test shows that the differences in anchorage strength compared to hooked bars in specimens when all values of tail cover are considered are not significant with $p \geq 0.10$. These comparisons again indicate that hooked bar anchorage strength was *not* affected by providing tail cover less than 2 in. (50 mm).

Hooked bars exhibiting tail kickout: Out of the 399 hooked bars used to determine the effect of tail cover on anchorage strength, 25 hooked bars in 20 specimens exhibited tail kickout. Of these, 19 were anchored inside the column core and six were anchored outside the column core. Sixteen of the hooked bars inside the column core had confining reinforcement and three did not, while the six hooked bars outside the column core did not have confining reinforcement. For hooked bars exhibiting tail kickout, the average test-to-calculated strength ratio T_{ind}/T_h is 1.05 for hooked bars inside the column core without confining reinforcement, as shown in Table 3.9. The average value of T_{ind}/T_h is 0.97 for the three hooked bars inside column core with confining reinforcement exhibiting tail kickout compared to the average of T_{ind}/T_h of 1.04 for all hooked bars placed inside column core with confining reinforcement. For the six hooked bars placed outside

the column core without confining reinforcement that exhibited tail kickout, the average value of T_{ind}/T_h is 0.95, compared to the average value of T_{ind}/T_h of 0.97 for all hooked bars placed outside the column core without confining reinforcement. When comparing the average values of T_{ind}/T_h for the hooked bars exhibiting tail kickout to that of the all specimens, Student's t-test shows that the differences in anchorage strength are *not* significant with all p above 0.10.

Overall, the results indicate that neither decreased tail cover nor tail kickout reduce the anchorage strength of hooked bars. Figure 3.14 shows T_{ind}/T_h with T_h based on Eq. (3.2) for hooked bars with tail cover less than 2 in. (50 mm) and hooked bars with tail kickout. The figure illustrates the insensitivity of anchorage strength to both tail kickout and low tail cover.

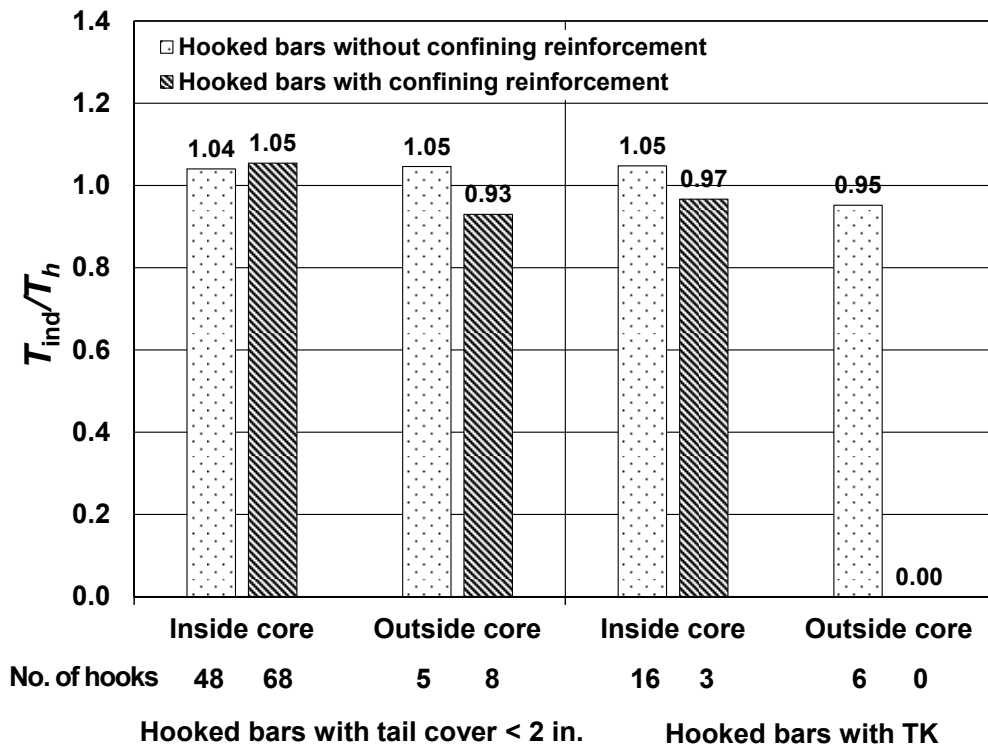

Figure 3.14 T_{ind}/T_h for hooked bars with concrete tail cover to the hook less than 2 in. (50 mm) and hooks with tail kickout (TK)

Figure 3.15 shows the percentage of hooked bars that exhibited tail kickout for each category of hooked bar placement, confining reinforcement, and tail cover. In the figure, the bars

are classified based on tail cover (< 2 in. [50 mm] or ≥ 2 in. [50 mm]), hooked bar placement (inside or outside column core), and confining reinforcement within the joint region (without or with). Although strength was not governed by tail kickout, the figure shows that for hooked bars inside or outside the column core, regardless of tail cover, the absence of confining reinforcement increases the tendency to have tail kickout at failure and that the percent is higher when the hooked bars are placed outside column core than when they are placed inside column core. The figure also shows that a tail cover less than 2 in. (50 mm) increases the tendency of having tail kickout. The combination of tail cover less than 2 in. (50 mm) and lack of confining reinforcement resulted in the greatest likelihood of a tail kickout, with 40% of the hooked bars placed outside the column core and 18.8% of hooked bars placed inside the column core with no confining reinforcement exhibiting tail kickout.

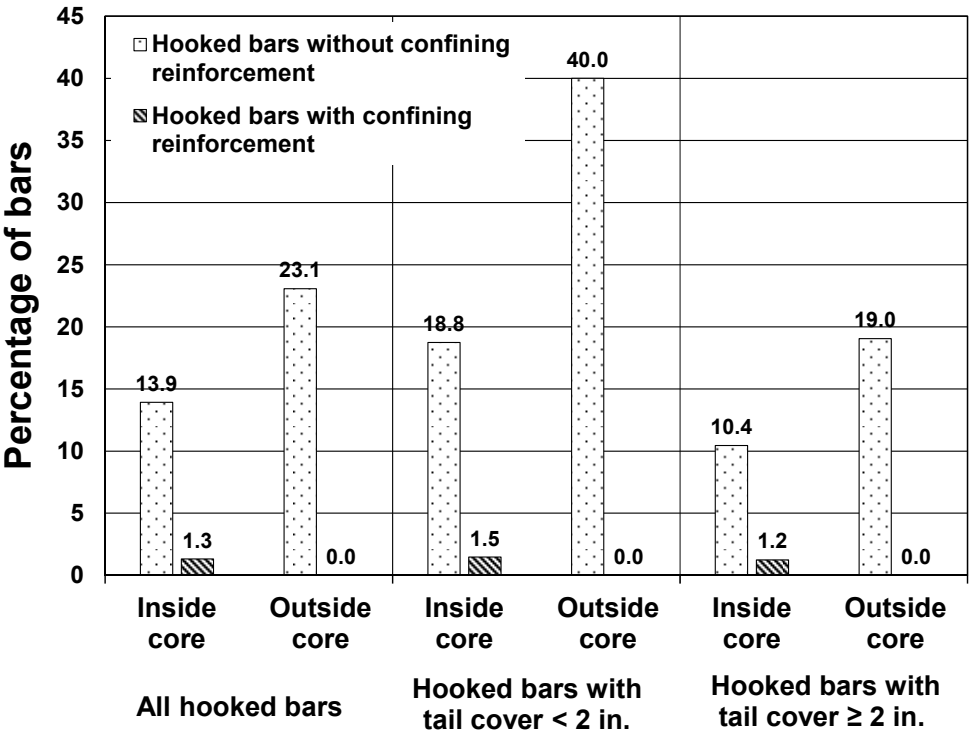

Figure 3.15 Percent of hooked bars inside and outside the column core exhibiting tail kickout with concrete tail cover less < 2 in. (50 mm) and tail cover ≥ 2 in. (50 mm)

Table 3.10 shows the number of hooked bars that exhibited tail kickout based on bar size. The table shows that out of the 25 hooked bars exhibiting tail kickout, fifteen were No. 11 (No. 36) hooked bars, nine were No. 8 (No. 25) hooked bars, and one was No. 5 (No. 16) hooked bar, indicating that for a given cover, the larger the bar size, the greater the tendency to exhibit tail kickout.

Table 3.10 Hooked bars exhibited tail kickout based on the bar size

Bar size		All bar sizes	No. 5 (No. 16)	No. 8 (No. 25)	No. 11 (No. 36)
Outside column core	Without confining reinforcement	6	---	3	3
	With confining reinforcement	---	---	---	---
Inside column core	Without confining reinforcement	16	1	6	9
	With confining reinforcement	3	---	---	3
Number of hooked bars (% with respect to the same bar size)		25 (6%)	1 (1%)	9 (4.5%)	15 (15.8%)

[ENREF 4](#) [ENREF 8](#) [ENREF 7](#)

3.5 SUMMARY AND CONCLUSIONS

In this study, 338 specimens were used to investigate the effects of hooked bar placement (inside versus outside the column core), the ratio of the effective depth to the embedment length, hooked bars extended halfway through the column depth, and hooked bars with tail cover less than 2 in. (50 mm) (the minimum cover required by Section 25.4.3.2 of ACI 318-14 to allow the use of the development length modification factor of 0.7 on anchorage strength). The specimens were cast in normalweight concrete and contained two, three, or four No. 5, 8, and 11 (No. 16, 25, and 36) hooked bars. Bar stresses at failure ranged from 27,100 to 141,000 psi (187 to 972 MPa) and concrete compressive strength ranged from 4,300 to 16,510 psi (30 to 114 MPa). Thirty seven specimens had the hooked bars placed outside the column core. Of these, 18 had no confining

reinforcement and 19 had confining reinforcement within the joint region. Twenty four specimens had the hooked bar anchored just halfway through the column, of which 10 had two hooked bars and 14 had three or four hooked bars. The effect of tail cover was investigated using 399 hooked bars with tail covers ranging from 0.75 to 4.5 in. (19 to 114 mm).

The following conclusions are based on the test results and analyses described in this chapter.

1. Placing hooked bars outside the column core results in a significantly lower anchorage strength than placing hooked bars inside the column core. In this study, the reduction ranged from 4 to 34%, producing an average anchorage strength equal to about 84% of the average strength of hooked bars placed inside the column core.
2. The dominant failure mode for all bars sizes is front failure for hooked bars placed inside column core. When hooked bars are placed outside column core, the dominant failure mode is front failure for No. 5 (No. 16) bars, while the dominant failure mode is side failure for No. 8 and No. 11 (No. 25 and No. 36) hooked bars.
3. Hooked bars anchored halfway through the column depth exhibit reductions in anchorage strength compared to those anchored at the far side of the column, with front failure as the dominant mode of failure for all specimens.
4. Hooked bars extended to the far side of the column in in simulated beam-columns joints exhibit reduced strength where the ratio of effective depth to the embedment length is greater than 1.5 compared to specimens where the ratio of effective depth to the embedment length less than or equal to 1.5.

5. The anchorage strength of hooked bars with a 90° bend angle is not affected by tail kickout at failure or hook tail covers as low as 0.75 in. (19 mm). The likelihood of tail kickout increases with increasing the bar size and for hooks with tail cover less than 2 in. (50 mm) and no confining reinforcement.

3.6 REFERENCES

AASHTO, 2012, *AASHTO LRFD Bridge Design Specifications*, 6th edition, American Association of State Highway and Transportation Officials, 1672 pp.

ACI Committee 318, 2014, *Building Code Requirements for Structural Concrete (ACI 318-14)*, American Concrete Institute, Farmington Hills, MI, 518 pp.

ASTM A615/A615M-15, 2015, *Standard Specification for Deformed and Plain Carbon-Steel Bars for Concrete Reinforcement*, ASTM International, West Conshohocken, PA., 8 pp.

ASTM A1035/A1035M-14, 2014, *Standard Specification for Deformed and Plain Low-Carbon, Chromium, Steel Bars for Concrete Reinforcement*, ASTM International, West Conshohocken, PA., 7 pp.

ASTM C494/C494M-13, *Standard Specification for Chemical Admixtures for Concrete* ASTM International, West Conshohocken, PA, 2013, 10 pp.

ASTM C1017/C1017M-13, *Standard Specification for Chemical Admixtures for Use in Producing Flowing Concrete*, ASTM International, West Conshohocken, PA, 2013, 9 pp.

Jirsa, J. O. and Marques, J. L. G., 1972, "A Study of Hooked Bar Anchorages in Beam-Column Joints," *Reinforced Concrete Research Council Project 33*, University of Texas at Austin Structures Research Laboratory, Austin, TX, 92 pp.

Joh, O., Goto, Y., and Shibata, T., 1995, "Anchorage of Beam Bars with 90-deg Bend in Reinforced Concrete Beam-Column Joints," *ACI Special Publication 157*, pp. 97-116.

Marques, J. L. G., 1972, *A Study of Anchorage Capacities of Confined Bent-Bar Reinforcement*, Master Thesis, Rice University, Houston, TX, 57 pp.

Marques, J. L. G., 1973, *A Study of Anchorage Capacities of Confined Bent-Bar Reinforcement*, Ph.D. Dissertation, Rice University, Houston, TX, 215 pp.

Marques, J. L. G. and Jirsa, J. O., 1975, "A Study of Hooked Bar Anchorages in Beam-Column Joints," *ACI Journal, Proceedings*, Vol. 72, No. 5, May, pp. 198-209.

Minor, J. and Jirsa, J. O., 1975, "Behavior of Bent Bar Anchorages," *ACI Journal, Proceedings* Vol. 72, No. 4, Apr., pp. 141-149.

Peckover, J., and Darwin, D., 2013, "Anchorage of High-Strength Reinforcing Bars with Standard Hooks: Initial Tests," *SL Report* No. 13-1, University of Kansas Center for Research, Lawrence, KS, 47 pp.

Sperry, J., Al-Yasso, S., Searle, N., DeRubeis, M., Darwin, D., O'Reilly, M., Matamoros, A., Feldman, L., Lepage, A., Lequesne, R., and Ajaam, A., 2015a, "Anchorage of High-Strength Reinforcing Bars With Standard Hooks," *SM Report* No. 111, The University of Kansas Center for Research, Lawrence, KS, 260 pp.

Sperry, J., Darwin, D., O'Reilly, M., and Lequesne, R., 2015b, "Anchorage Strength of Conventional and High-Strength Hooked Bars in Concrete," *SM Report* No. 115, The University of Kansas Center for Research, Lawrence, KS, 281 pp.

Sperry, J.; Yasso, S.; Searle, N.; DeRubeis, M.; Darwin, D.; O'Reilly, M.; Matamoros, A.; Feldman, L.; Lepage, A.; and Lequesne, R., 2017a, "Conventional and High-Strength Hooked Bars—Part 1: Anchorage Tests," *ACI Structural Journal*, Vol. 114, No. 1, Jan.-Feb., pp. 255-266.

Sperry, J.; Darwin, D.; O'Reilly, M.; Matamoros, A.; Feldman, L.; Lepage, A.; and Lequesne, R., and Yasso, S., 2017b, "Conventional and High-Strength Hooked Bars—Part 2: Data Analysis," *ACI Structural Journal*, Vol. 114, No. 1, Jan.-Feb., pp. 267-276.

CHAPTER 4: HOOKED BAR DESIGN PROVISIONS

4.1 INTRODUCTION

Hooked bars are used in reinforced concrete where member dimensions do not allow for straight bar development, such as exterior beam-column joints and beam-wall or slab-wall connections. The ACI Building Code (ACI 318-14) hooked bar development length design provisions were developed based on tests of 38 simulated beam-column joints containing two hooked bars by Marques and Jirsa (1975) and Pinc et al. (1977). The provisions include modification factors that recognize the effects of concrete cover, confining reinforcement within the joint region, type of concrete, and bar surface condition. The strength of members with more than two hooked bars and the effects of hooked bar spacing and placement within a member were neither studied nor considered when the ACI provisions were developed.

Recent research by Sperry et al. (2015a, 2015b, 2017a, and 2017b) and Chapters 2 and 3 of this study has addressed the effect of concrete compressive strength, range of bar stress at failure, concrete side cover, confining reinforcement, hook bend angle, hooked bar spacing, and placement of hooked bars within a column. A reliability-based design expression was developed by Sperry et al. (2015b) based on test results for 245 specimens with two widely-spaced hooked bars. The expression serves as the basis for the design provisions presented in this chapter. The effects of close spacing between hooked bars and hooked bar placement were studied in Chapters 2 and 3, and it was found that the equation by Sperry et al. (2015b) required modification to account for the effect of close spacing between hooked bars and hooked bars placed outside of the column core or not extended to the back of the column. The applicability of the developed design expression by Sperry et al. (2015b) with the modification factors suggested in Chapters 2 and 3 is

evaluated using specimens with closely-spaced hooked bars, hooked bars extended halfway through the column depth, and hooked bars embedded in walls, the later tested by Johnson and Jirsa (1981). A final design expression is proposed that retains the modification factors in ACI 318-14 for the effects of epoxy-coated bars and the lightweight concrete, which were not considered in the current study.

4.2 RESEARCH SIGNIFICANCE

The ACI Building Code (ACI 318-14) and AASHTO LRFD Bridge Design Specifications (2012) provisions for hooked bar design are based on a limited number of beam-column joint specimens containing two hooked bars. The provisions do not account for the effects of the spacing or placement of hooked bars in the supporting member. This study proposes development length design provisions that, for the first time, address these considerations.

4.3 DESIGN EXPRESSION

The design expression for the development length of hooked bars is a modification of an expression, Eq. (4.1), proposed by Sperry et al. (2015b) based on test results for 245 simulated beam-column joints with two widely-spaced hooked bars, 99 without confining reinforcement from studies by Marques and Jirsa (1975), Pinc et al. (1977), Hamad et al. (1993), Ramirez and Russell (2008), Lee and Park (2010), and Sperry et al. (2015b). Specimens with confining reinforcement included 146 beam-column joints with two widely-spaced hooked bars tested by Sperry et al. (2015b).

$$\ell_{dh} = \left(0.0018 \frac{f_y \Psi_r}{f_c^{0.25}} \right) d_b^{1.5} \quad (4.1)$$

where, ℓ_{dh} is the development length (in.); f_y is the yield strength of the bar (psi); f_c is the concrete compressive strength (psi), and d_b is the bar diameter (in.). Ψ_r is a modification factor that accounts

for the effect of confining reinforcement within the joint region. Specimens used to develop Eq. (4.1) had bar stresses at failure up to 137,400 psi (945 MPa) and concrete compressive strengths up to 16,510 psi (110 MPa). The range of strengths covered by Eq. (4.1) will allow the use of high-strength concrete up to 16,000 psi (110 MPa) and high-strength reinforcing steel up to Grade 120 (830 MPa) in design.

For hooked bars with confining reinforcement parallel to the straight portion of the hooked bar,

$$\psi_r = \frac{f_s d_b^{1.5} - 48,900 N A_{tr} / n}{f_s d_b^{1.5}} \leq 1.0 \quad (4.2)$$

where A_{tr} is area of one leg of confining reinforcement (in.^2), and N is the number of legs of confining reinforcement within $8d_b$ from the top of the hooked bar for No. 8 (No. 25) bars and smaller or within $10d_b$ for No. 9 (No. 28) bars or larger, which equal to the bend diameter of a 180° hook, as shown in Figure 4.1, and n is the number of hooked bars in the joint confined by N legs.

For hooked bars with confining reinforcement perpendicular to the straight portion of the bar

$$\psi_r = \frac{f_s d_b^{1.5} - 1,330 f_c^{0.25} N A_{tr} / n}{f_s d_b^{1.5}} \leq 1.0 \quad (4.3)$$

where N is the number of legs for confining reinforcement within the development length ℓ_{dh} .

Equation (4.1) applies for confining reinforcement perpendicular or parallel to the straight portion of the hooked bar for both 90° and 180° hooks. This differs from the provisions of the ACI 318-14, which permits using both orientations of confining reinforcement for 90° hooks, but only confining reinforcement perpendicular to the straight portion of the bar for 180° hooks.

For specimens with confining reinforcement, NA_{tr}/n ranged from 0.06 to 0.6, corresponding to ψ_r values ranging from 1.0 to 0.67 (for hooked bars without confining reinforcement, $\psi_r = 1.0$). Due to a lack of data, Sperry et al. (2015b) recommended that the value of ψ_r not be taken less than 0.7.

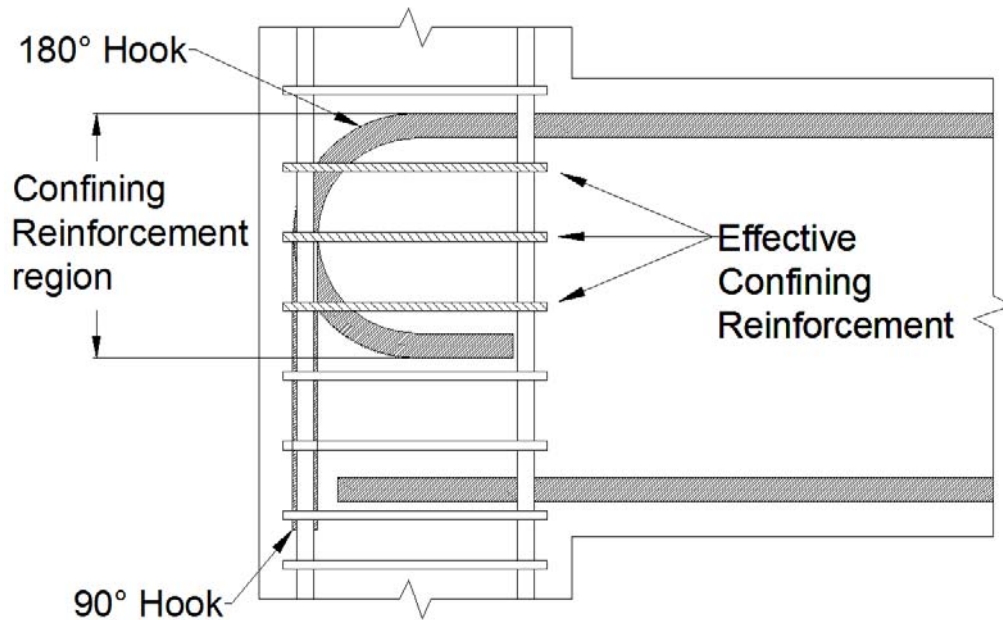

Figure 4.1 Region over which confining reinforcement is effective for 90° and 180° hooks

Tables 4.1a, 4.1b, and 4.1c show the values of ψ_r based on Eq. (4.2) for $f_y = 60,000, 80,000,$ and $100,000$ psi (415, 550, and 690 MPa), respectively, for hooked bars with sizes ranging from No. 3 (No. 10) through No. 11 (No. 36) when confined by No. 3 (No. 10) bars ($A_{tr} = 0.11 \text{ in.}^2$ [71 mm^2]) parallel to the straight portion of the hooked bar. The values are expressed as a function of the number of confining legs per hook N/n ranging from 0.5 to 4.0. Values for N/n equal to 1 and 3 correspond to six hooked bars confined by hoops spaced at $3d_b$ and two hooked bars confined by hoops spaced at $3d_b$, respectively. As shown in the tables, substantial reductions in ℓ_{dh} may be obtained in regions of high confinement, especially for small hooked bars. A lower limit for ψ_r of 0.7 is used because the minimum value tested was 0.67 (Sperry et al. 2015b). Designers will have

the option of calculating the value of ψ_r based on Eq. (4.2) or selecting a value based on bar size, stress in the bar, and the ratio of number of legs confining the hooked bars to the number of bars developed N/n .

Table 4.1a Values of ψ_r for hooked bars with $f_y = 60,000$ psi (420 MPa) confined by No. 3 (No. 10) bars

Bar Designation No. (SI)	3 (10)	4 (13)	5 (16)	6 (19)	7 (22)	8 (25)	9 (29)	10 (32)	11 (36)
Bar diameter, d_b , in.	0.375	0.500	0.625	0.750	0.875	1.000	1.128	1.270	1.410
N/n^*									
0.50	0.80	0.87	0.91	0.93	0.95	0.96	0.96	0.97	0.97
1.00	0.70	0.75	0.82	0.86	0.89	0.91	0.93	0.94	0.95
2.00	0.70	0.70	0.70	0.72	0.78	0.82	0.85	0.87	0.89
3.00	0.70	0.70	0.70	0.70	0.70	0.73	0.78	0.81	0.84
4.00	0.70	0.70	0.70	0.70	0.70	0.70	0.70	0.75	0.79

* N = Number of legs of confining reinforcement – based on dimensions of 180° hooks for hooked bars with bend angles of 90° and 180°; n = Number of hooked bars being developed

Shaded cells indicate calculated value of $\psi_r < 0.70$

Note: 1 in. = 25.4 mm

Table 4.1b Values of ψ_r for hooked bars with $f_y = 80,000$ psi (550 MPa) confined by No. 3 (No. 10) bars

Bar Designation No. (SI)	3 (10)	4 (13)	5 (16)	6 (19)	7 (22)	8 (25)	9 (29)	10 (32)	11 (36)
Bar diameter, d_b , in.	0.375	0.500	0.625	0.750	0.875	1.000	1.128	1.270	1.410
N/n^*									
0.50	0.85	0.90	0.93	0.95	0.96	0.97	0.97	0.98	0.98
1.00	0.71	0.81	0.86	0.90	0.92	0.93	0.94	0.95	0.96
2.00	0.70	0.70	0.73	0.79	0.84	0.87	0.89	0.91	0.92
3.00	0.70	0.70	0.70	0.70	0.75	0.80	0.83	0.86	0.88
4.00	0.70	0.70	0.70	0.70	0.70	0.73	0.78	0.81	0.84

* N = Number of legs of confining reinforcement – based on dimensions of 180° hooks for hooked bars with bend angles of 90° and 180°; n = Number of hooked bars being developed

Shaded cells indicate calculated value of $\psi_r < 0.70$

Note: 1 in. = 25.4 mm

Table 4.1c Values of ψ_r for hooked bars with $f_y = 100,000$ psi (690 MPa) confined by No. 3 (No. 10) bars

Bar Designation No. (SI)	3 (10)	4 (13)	5 (16)	6 (19)	7 (22)	8 (25)	9 (29)	10 (32)	11 (36)
Bar diameter, d_b , in.	0.375	0.500	0.625	0.750	0.875	1.000	1.128	1.270	1.410
N/n^*									
0.50	0.88	0.92	0.95	0.96	0.97	0.97	0.98	0.98	0.98
1.00	0.77	0.85	0.89	0.92	0.93	0.95	0.96	0.96	0.97
2.00	0.70	0.70	0.78	0.83	0.87	0.89	0.91	0.92	0.94
3.00	0.70	0.70	0.70	0.75	0.80	0.84	0.87	0.89	0.90
4.00	0.70	0.70	0.70	0.70	0.74	0.78	0.82	0.85	0.87

* N = Number of legs of confining reinforcement – based on dimensions of 180° hooks for hooked bars with bend angles of 90° and 180° ; n = Number of hooked bars being developed

Shaded cells indicate calculated value of $\psi_r < 0.70$

Note: 1 in. = 25.4 mm

For specimens with confinement perpendicular to the straight portion of the hooked bar, the contribution of each leg of confining reinforcement on hooked bar anchorage strength is lower than that provided by parallel confinement. Using Eq. (4.3) is more convenient than using tabulated values when placing the confinement perpendicular to the straight portion of the hooked bar, as the appearance of concrete compressive strength in Eq. (4.3) makes tabulation of ψ_r values more complicated.

Figure 4.2 compares the measured and calculated failure loads using Eq. (4.1) for the 99 specimens containing two widely-spaced hooked bars without confining reinforcement within the joint region ($\psi_r=1.0$) that were used to develop Eq. (4.1). Specimen details are shown in Appendix C. The average embedment lengths ranged from 5.0 to 26.0 in. (125 to 660 mm), concrete compressive strengths ranged from 2,570 to 16,510 psi (18 to 114 MPa), and the stresses in the bars at failure ranged from 30,800 to 136,100 psi (212 to 939 MPa). The vast majority of the

specimens have a test-to-calculated strength ratio of 1.0 or greater; only six specimens have a test-to-calculated strength ratio below 1.0 with a minimum value of 0.895.

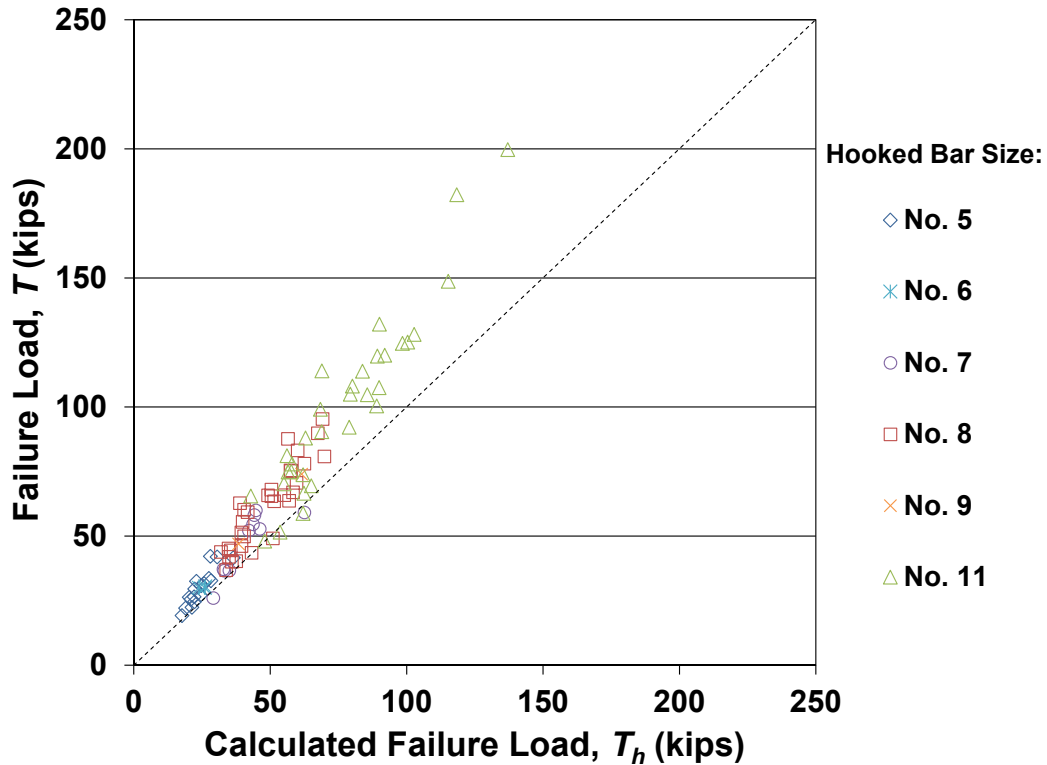

Figure 4.2 Measured versus calculated bar failure load for specimens containing two widely-spaced hooked bars without confining reinforcement, with T_h based on Eq. (4.1)

Figure 4.3 compares the failure loads with those calculated using Eq. (4.1) for the 146 specimens with confining reinforcement at the joint region that were used to develop Eq. (4.1). The details for these specimens are also shown in Appendix C. The average embedment lengths ranged from 3.75 to 22.0 in. (95 to 560 mm), concrete compressive strengths ranged from 4,300 to 15,800 psi (30 to 109 MPa), and the stresses in the bars at failure ranged from 41,000 to 137,400 psi (283 to 948 MPa). Again, the majority of the specimens have a test-to-calculated strength ratio of 1.0 or greater; only eight specimens have a test-to-calculated strength ratio below 1.0 with minimum value of 0.824.

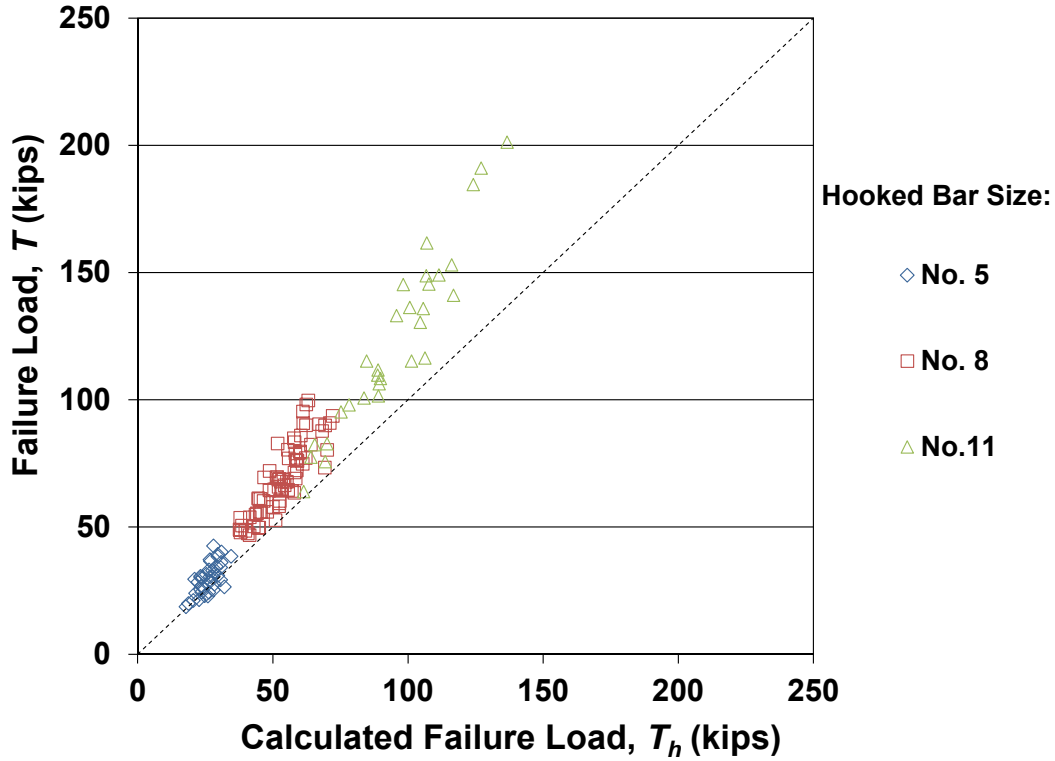

Figure 4.3 Measured versus calculated bar failure load for specimens containing two widely-spaced hooked bars with confining reinforcement, with T_h based on Eq. (4.1)

4.3.1 Closely-spaced hooked bars

As shown in Chapter 2, the specimens with closely-spaced hooked bars exhibited lower anchorage strength per bar than specimens with widely-spaced hooked bars; the ratio between the anchorage strengths of the closely and widely-spaced hooked bars were presented for specimens without and with confining reinforcement. The strength ratio can be used to develop modification factors ψ_m that account for the effect of bar spacing of closely-spaced hooked bars on the required development length. For hooked bars without and with confining reinforcement,

$$\psi_m = \frac{1}{\omega_s} \geq 1.0 \quad (4.4)$$

For specimens without confining reinforcement

$$\omega_s = \left(0.085 \frac{c_{ch}}{d_b} + 0.42 \right) \quad (4.5)$$

For specimens with confining reinforcement that have NA_{tr}/n of 0.22

$$\omega_s = \left(0.035 \frac{c_{ch}}{d_b} + 0.74 \right) \quad (4.6)$$

where c_{ch} is the center-to-center spacing between hooked bars and d_b is the hooked bar diameter.

For any amount of NA_{tr}/n between 0 and 0.22, a linear interpolation between Eq. (4.5) and (4.6) is

used to calculate the value of ω_s .

$$\omega_s = \frac{NA_{tr}/n}{0.22} \left[\left(0.035 \frac{c_{ch}}{d_b} + 0.74 \right) - \left(0.085 \frac{c_{ch}}{d_b} + 0.42 \right) \right] + \left(0.085 \frac{c_{ch}}{d_b} + 0.42 \right) \quad (4.7)$$

$$\text{and } \frac{NA_{tr}}{n} + (0.59) \leq \omega_s \leq 1.0 .$$

The value of ω_s is equal to 1.0 when the center-to-center spacing c_{ch} is greater than $7d_b$.

This suggests that for a spacing greater than approximately $7d_b$, hooked bars are far enough apart so that they do not interact, and therefore, can be treated as widely-spaced hooked bars.

The minimum center-to-center spacing c_{ch} should comply with spacing requirements in Section 25.2 of ACI 318-14, where the minimum value of c_{ch} shall be the bar diameter d_b plus the greatest of 1 in. (25 mm), d_b , and $^{4}/_3d_{agg}$, where d_{agg} is the nominal maximum size of coarse aggregate. Incorporating ψ_m in Eq. (4.1) gives

$$\ell_{dh} = \left(0.0018 \frac{f_y \Psi_r \Psi_m}{f_c^{0.25}} \right) d_b^{1.5} \quad (4.8)$$

Figure 4.4 compares the failure loads and with those calculated using Eq. (4.8) for 15 specimens containing three or four closely-spaced hooked bars without confining reinforcement at the joint region (described earlier in Chapter 2), along with the 99 specimens containing two widely-spaced hooked bars without confining reinforcement shown in Figure 4.2. For the 15 specimens, the average embedment lengths ranged from 5.2 to 16.1 in. (130 to 410 mm), concrete compressive strengths ranged from 4,490 to 11,460 psi (31 to 79 MPa), and the stresses in the bars

at failure ranged from 36,100 to 91,600 psi (249 to 632 MPa). The figure shows that all 15 specimens have a test-to-calculated strength ratio greater than 1.0.

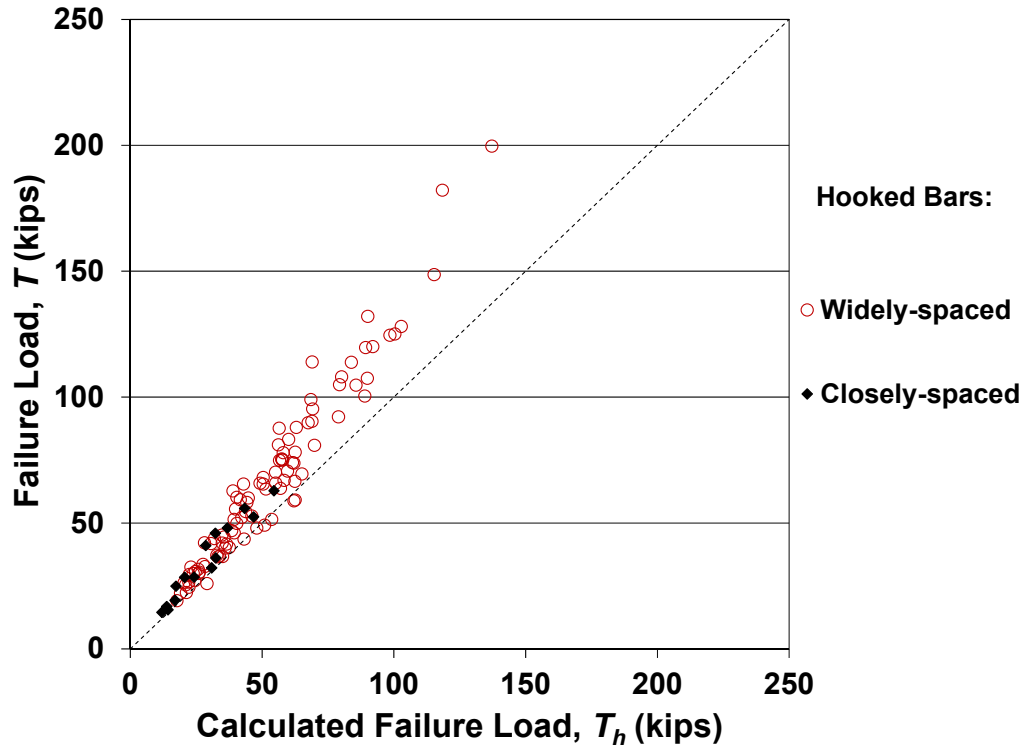

Figure 4.4 Measured versus calculated bar failure load for hooked bars without confining reinforcement, including specimens with closely-spaced hooked bars, with T_h based on Eq. (4.8)

Figure 4.5 compares the failure loads and with those calculated using Eq. (4.8) for 25 specimens containing three or four closely-spaced hooked bar with confining reinforcement within the joint region (described earlier in Chapter 2) along with the 146 specimens containing two hooked bars with confining reinforcement (Figure 4.3). For the 25 specimens with closely-spaced hooked bars, the average embedment lengths ranged from 5.5 to 14.88 in. (140 to 380 mm), concrete compressive strengths ranged from 4,760 to 11,460 psi (33 to 79 MPa), and the stresses in the bars at failure ranged from 39,700 to 117,100 psi (274 to 808 MPa). Figure 4.5 shows that 22 specimens out of 25 had test-to-calculated strength ratio greater than 1.0; the lowest test-to-calculated strength ratio is 0.89.

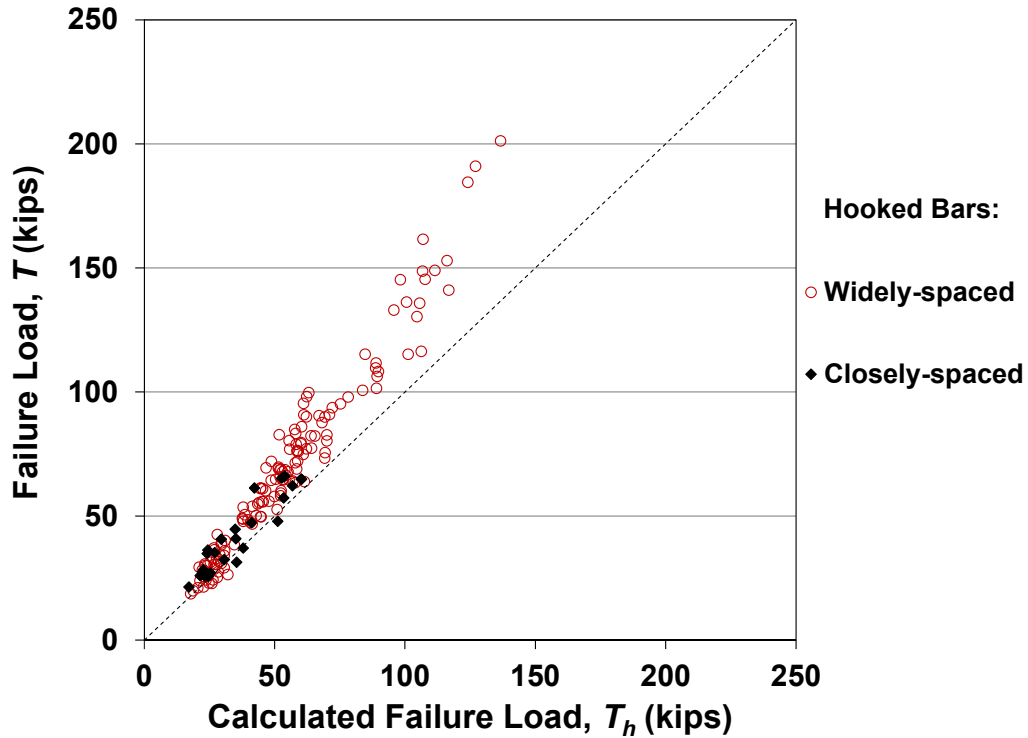

Figure 4.5 Measured versus calculated bar failure load for hooked bars with confining reinforcement, including multiple-hook specimens, with T_h based on Eq. (4.8)

Table 4.2 shows the maximum, minimum, mean, standard deviation, and coefficient of variation for the ratio of T/T_h for the 40 specimens with three or four closely-spaced hooked bars in Figures 4.4 and 4.5. The anchorage strength is calculated using Eq. (4.8), which accounts for the effect of center-to-center spacing between the bars. The results show that Eq. (4.8), with the suggested modifications, accounts for the effect of closely-spaced hooked bars in design.

Table 4.2 Statistical parameters for test-to-calculated forces (T/T_h) for closely-spaced hooked bar specimens without and with confining reinforcement in Figure 4.4 and 4.5

(No. of specimens)	Specimens without confining reinforcement (15)	Specimens with confining reinforcement (25)
Maximum	1.44	1.49
Minimum	1.05	0.89
Mean	1.24	1.18
Standard Deviation	0.13	0.16
Coefficient of Variation	0.11	0.13
No. with $T/T_h < 1.0$	0	3

4.3.2 Hooked bars outside column core or not extended to the far side of the column

Chapter 3 shows that hooked bars placed outside the column core exhibit about 20% lower anchorage strength compared with those placed inside the column core. Hooked bars extended halfway through the column depth, where the hook is located outside the column compression region, exhibit about 20% lower anchorage strength compared with hooked bars extended to the far side of the column. To address this in design, the development length calculated using Eq. (4.8) should be modified by a placement factor ψ_o when hooked bars are placed outside the column core or not extended to the far side of the column. A value for ψ_o of 1.25 is chosen based on the test results from Chapter 3 so that the majority of specimens with hooked bars placed outside the column core or not extended to the far side of the column will have a test-to-calculated strength ratio greater than or equal to 1.0. When hooked bars are placed inside the column core or extended to the far side of the column, $\psi_o = 1.0$. The design expression, not including the effect of epoxy-coated reinforcement or lightweight concrete modification factors, then becomes:

$$\ell_{dh} = \left(0.0018 \frac{f_y \Psi_r \Psi_m \Psi_o}{f_c^{0.25}} \right) d_b^{1.5} \quad (4.9)$$

Figure 4.6 compares the failure loads and with those calculated using Eq. (4.9) for the specimens shown in Figure 4.2, plus nine specimens with closely-spaced hooked bars extended halfway through the column depth (six with three or four hooked bars and three with two hooked bars) and 20 specimens with two hooked bars placed outside the column core, all without confining reinforcement within the joint region. For the latter 29 specimens, the average embedment lengths ranged from 4.75 to 25.19 in. (120 to 640 mm), concrete compressive strengths ranged from 4,420 to 11,800 psi (30 to 81 MPa), and the stresses in the bars at failure ranged from 22,800 to 112,000 psi (157 to 772 MPa). For specimens with hooked bars placed outside column core, only placement

modification factor ψ_o of 1.25 is applied, while placement and spacing modification factors are applied to specimens with closely-spaced hooked bars extended halfway through the column depth. All specimens with hooked bars placed outside the column core have a test-to-calculated strength ratio greater than 1.0 with minimum value of 1.13. Two out of the nine specimens with closely-spaced hooked bars extended halfway through the column depth have ratio of test-to-calculated strength ratio below 1.0, with values of 0.79 and 0.90 corresponding to stresses in the bar at failure of 22,800 and 23,600 psi (157 and 163 MPa), respectively. The average test-to-calculated strength ratio of specimens with closely-spaced hooked bars extended halfway through the column depth is 1.16.

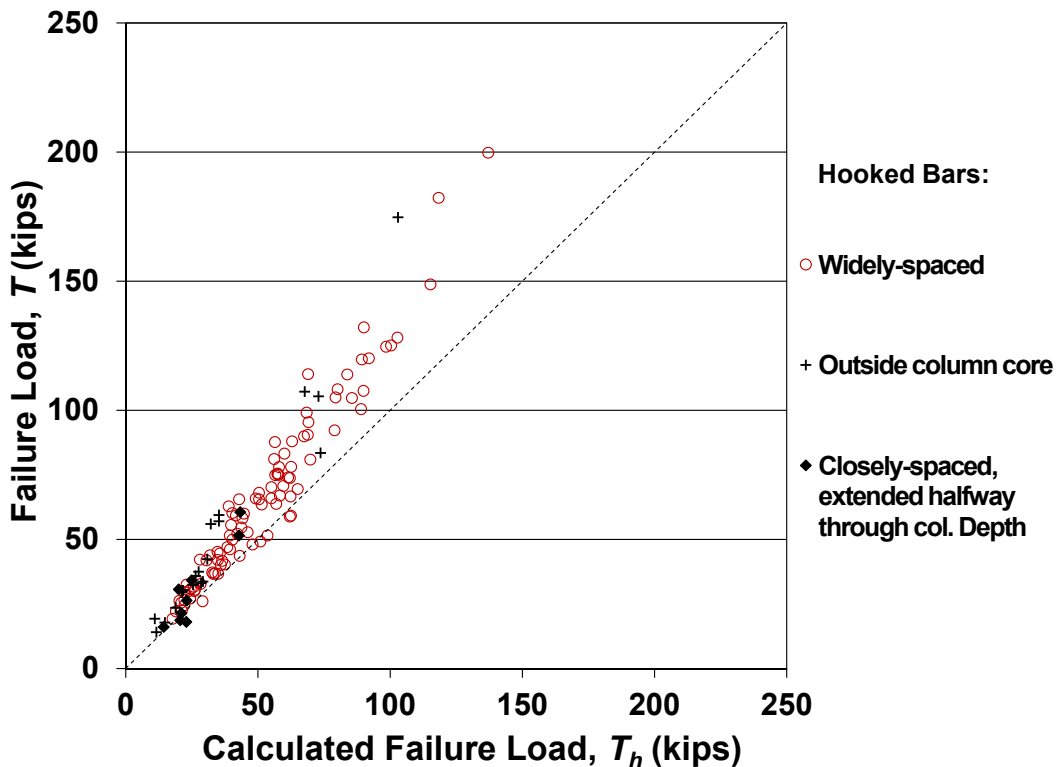

Figure 4.6 Measured versus calculated bar failure load for hooked bars without confining reinforcement, including two- and multiple-hook specimens outside the compression region, and specimens with hooked bars outside the column core, with T_h based on Eq. (4.9)

Figure 4.7 compares the failure loads with those calculated using Eq. (4.9) for specimens with confining reinforcement within the joint region. Figure 4.7 shows the results for the specimens in Figure 4.3 in addition to 19 specimens with two hooked bars placed outside the column core and thirteen specimens with closely-spaced hooked bars extended halfway through the column depth, of which eight had three or four hooked bars and five had two hooked bars. Both ψ_m and ψ_o are applied for specimens with closely-spaced hooked bars not extended to the far side of the column to account for both effects. Three out of 19 specimens with hooked bars placed outside the column core had a test-to-calculated strength ratio below 1.0, with a minimum value of 0.90 and an average of 1.34. Two out of thirteen specimens with closely-spaced hooked bars extended halfway through the column depth have test-to-calculated strength ratio below 1.0, with values of 0.86 and 0.95, corresponding to stresses in the bar at failure of 37,300 and 39,800 psi (257 and 274 MPa) respectively. The average test-to-calculated strength ratio of specimens with closely-spaced hooked bars extended halfway through the column depth is 1.43.

The results show that using the hooked bar placement factor ψ_o of 1.25 in design accounts for the effect of placing the hooked bars outside column core or when hooked bars are not extended to the far side of the column.

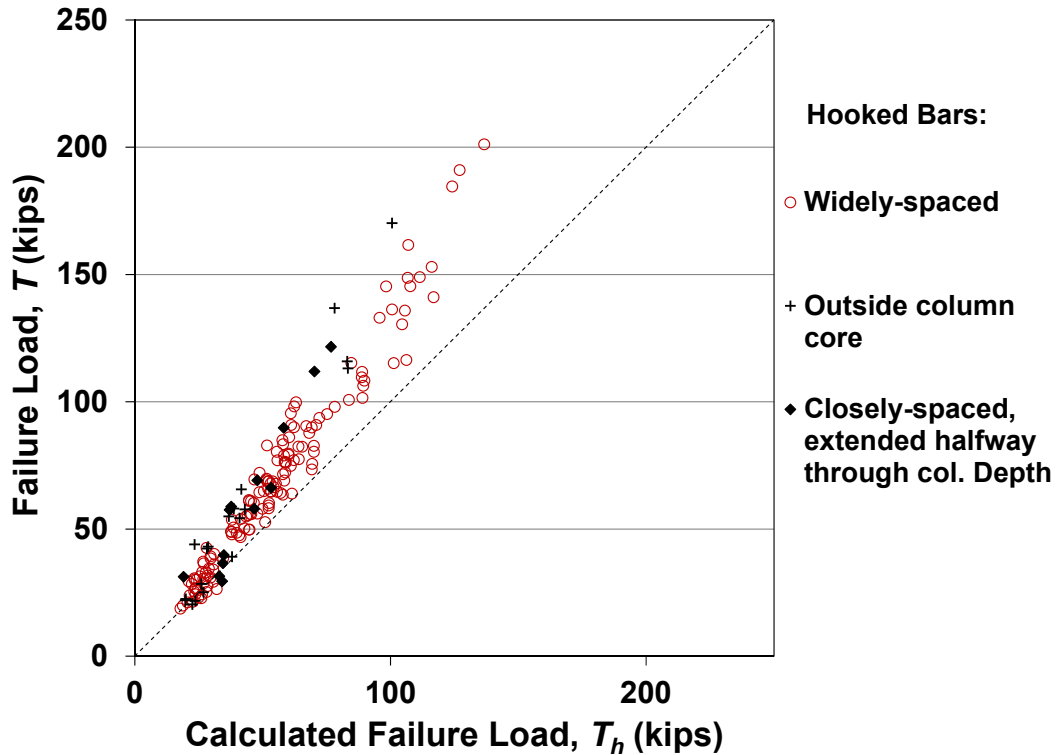

Figure 4.7 Measured versus calculated bar failure load for hooked bars with confining reinforcement, including two- and multiple-hook specimens outside the compression region, and specimens with hooked bars outside the column core, with T_h based on Eq. (4.9)

4.3.3 Hooked bars in walls

In addition to beam-column joints, hooked bars are used in slab-to-wall connections, where they usually have a shallow embedment length. The study by Johnson and Jirsa (1981) described in Chapter 1 examined hooked bars embedded in walls. Thirty specimens were considered with average embedment lengths ranging from 2.0 to 7.0 in. (50 to 175 mm), concrete compressive strength ranging from 2,400 to 5,450 psi (17 to 38 MPa), and stresses in bars at failure ranging from 14,170 to 60,000 psi (98 to 414 MPa). One specimen had a 2.0-in. (50-mm) embedment length, ten had a 3.5 in. (90 mm), eight had a 5.5-in. (140-mm) embedment length, three had a 6.5-in. (165-mm) embedment length, and eight had a 7.0-in. (175-mm) embedment length. All embedment lengths were shorter than the minimum lengths of 6 in. (150 mm) or $8d_b$ required by

Section 25.4.3.1 of ACI 318-14. The horizontal distance from the side of the concrete wall to the center of the hooked bars ranged from $8d_b$ to $24d_b$, which is more than the $7d_b$ limit applied for the closely-spaced hooked bars factor in Eq. (4.9). For the wall specimens, the high concrete side cover provided a degree of confinement similar to that provided to hooked bars placed inside a column core (Sperry et al. 2015a). Thus, $\psi_o = 1.0$ is used for these specimens.

The failure loads of the hooked bars embedded in walls tested by Johnson and Jirsa (1981) are compared to the strengths calculated using Eq. (4.9) and shown in Figure 4.8. Four out of 30 specimens had a test-to-calculated strength ratio less than 1.0. Those specimens, however, had embedment lengths of either 2.0 or 3.5 in. (50 or 90 mm), which are shorter than the embedment lengths used to develop Eq. (4.9) and shorter than what is permitted by ACI 318-14. The maximum, minimum and mean test-to-calculated strength ratios T/T_h are 1.59, 0.84, 1.16, for specimens with embedment lengths of 3.5 in. (90 mm) and less, while the ratios were 1.39, 1.76, and 0.84 for specimens with embedment length of 5.5 in (140 mm) and more. The test results for the specimens are summarized in Table 4.3. The results show that using $\psi_o = 1.0$ for hooked bars located outside the column core is appropriate when concrete cover is greater than $7d_b$.

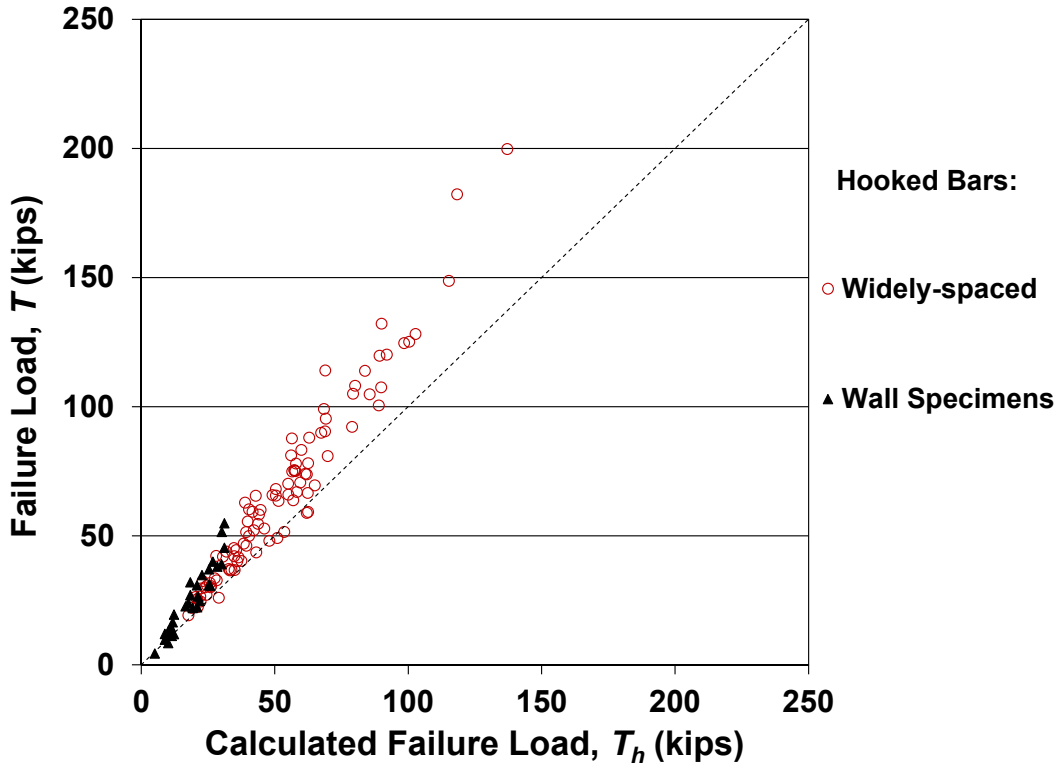

Figure 4.8 Measured versus calculated bar failure load for hooked bars without confining reinforcement, including hooks embedded in walls, with T_h based on Eq. (4.9)

Table 4.3 Measured versus calculated bar failure loads for hooked bars in walls tested by Johnson and Jirsa (1981), with T_h based on Eq. (4.9)

Specimen	Embedment length (in.)	T (kips)	T_h (kips)	T/T_h
4-3.5-8-M	2	4.4	5.1	0.87
4-5-11-M	3.5	12	8.8	1.36
4-5-14-M	3.5	9.8	8.8	1.11
7-5-8-L	3.5	13	10.1	1.29
7-5-8-M	3.5	16.5	11.8	1.40
7-5-8-H	3.5	19.5	12.3	1.59
7-5-8-M	3.5	14.7	11.1	1.32
7-5-14-L	3.5	8.5	10.1	0.84
7-5-14-M	3.5	11.2	11.4	0.98
7-5-14-H	3.5	11.9	12.3	0.97
7-5-14-M	3.5	11.3	11.1	1.02
7-7-8-M	5.5	32	18.4	1.74
7-7-11-M	5.5	27	18.4	1.47
7-7-14-M	5.5	22	19.3	1.14
9-7-11-M	5.5	30.8	20.9	1.48
9-7-14-M	5.5	24.8	21.9	1.13
9-7-18-M	5.5	22.3	21.0	1.06
7-8-11-M	6.5	34.8	22.7	1.53

Table 4.3 Cont. Measured versus calculated bar failure loads for hooked bars in walls tested by Johnson and Jirsa (1981), with T_h based on Eq. (4.9)

7-8-14-M	6.5	26.5	21.2	1.25
9-8-14-M	6.5	30.7	25.8	1.19
11-8.5-11-L	7	37	25.4	1.46
11-8.5-11-M	7	51.5	30.2	1.71
11-8.5-11-H	7	54.8	31.2	1.76
11-8.5-14-L	7	31	25.4	1.22
11-8.5-14-M	7	39	30.1	1.30
11-8.5-14-H	7	45.4	31.2	1.46
7-7-11-M	5.5	24	17.6	1.36
7-7-11-L	5.5	22.7	16.6	1.37
11-8.5-11-M	7	38	28.5	1.33
11-8.5-11-L	7	40	26.8	1.49

The final design expression after adding modification factors for the epoxy-coated reinforcement ψ_e and lightweight concrete λ (unchanged from ACI 318-14) is

$$\ell_{dh} = \left(0.0018 \frac{f_y \Psi_r \Psi_m \Psi_o \Psi_e}{\lambda f_c^{0.25}} \right) d_b^{1.5} \quad (4.10)$$

4.4 COMPARISON WITH ACI 318-14 HOOKED BAR DESIGN EXPRESSION

The expression for the development length of hooked bars in Section 25.4.3.2 (a) of ACI 318-14 is

$$\ell_{dh} = \left(\frac{f_y \Psi_e \Psi_c \Psi_r}{50 \lambda \sqrt{f_c'}} \right) d_b \quad (4.11)$$

The proposed design provisions incorporated in Eq. (4.10) include several major changes compared with those in ACI 318-14, including the effects of concrete compressive strength, confining reinforcement, bar size, bar spacing, and bar placement.

The proposed and ACI 318-14 design provisions for the development length of hooked bars can be compared by solving Eq. (4.10) and (4.11), respectively, for the stress f_y , converting the stress to force and treating this force as the calculated force for the given concrete compressive strength, development length, bar diameter, cover, degree of confinement, and in the case of Eq.

(4.11), bar spacing and bar placement within a member. When solving Eq. (4.10) and (4.11) for anchorage force, concrete compressive strength is replaced by the measured compressive strength f_{cm} and the development length is replaced with embedment length ℓ_{eh} . The ACI 318-14 equation, Eq. (4.11), becomes

$$T_h = \left(\frac{50\pi \ell_{eh} \lambda \sqrt{f_{cm}}}{4 \Psi_e \Psi_c \Psi_r} \right) d_b \quad (4.12)$$

Solving Eq. (4.10) for anchorage force gives

$$T_h = \left(436 \frac{\ell_{eh} \lambda f_{cm}^{0.25}}{\Psi_r \Psi_m \Psi_o \Psi_e} \right) d_b^{0.5} \quad (4.13)$$

where T_h represents the anchorage force (lb), ℓ_{eh} is the embedment length (in.), f_{cm} is the measured concrete compressive strength (psi), and d_b is the bar diameter (in.). The forces calculated from Eq. (4.12) and (4.13) can, in turn, be compared with the anchorage strengths for the specimens used to develop Eq. (4.1) (Sperry et al. 2015b) and the other specimens used to develop the modification factors for the effect of hooked bar spacing and placement. When using the ACI 318-14 design provisions, the maximum limit on $\sqrt{f_{cm}}$ of 100 psi (8.3 MPa) for concrete compressive strength is applied, as are the 0.7 and 0.8 modification factors from Table 25.4.3.2 of ACI 318-14 related to cover and confining reinforcement, where applicable. The 0.7 modification factor applies for No. 11 bars and smaller when at least 2.5 in. (65 mm) clear side cover and 2.0 in. (50 mm) clear tail cover to the hook tail are provided, while the 0.8 factor applies when the hooked bar is confined by hoops or ties spaced no further than three bar diameter apart. Since the hooked bars were uncoated and embedded in normalweight concrete, the epoxy-coated reinforcement and lightweight concrete modification factors are taken as 1.0 for both equations. The distributions of

the test-to-calculated strength ratios for the two provisions are compared for specimens without and with confining reinforcement.

Figure 4.9 shows the distribution of the test-to-calculated strength ratios T/T_h for specimens with two widely-spaced hooked bars without confining reinforcement based on ACI 318-14 and on the proposed design provisions. The values of T/T_h exhibit less scatter when using the proposed provisions than when using those in ACI 318-14. In addition, 31% of the test-to-calculated strength ratios for ACI 318-14 fall below 1.0, compared to 6% for the proposed provisions.

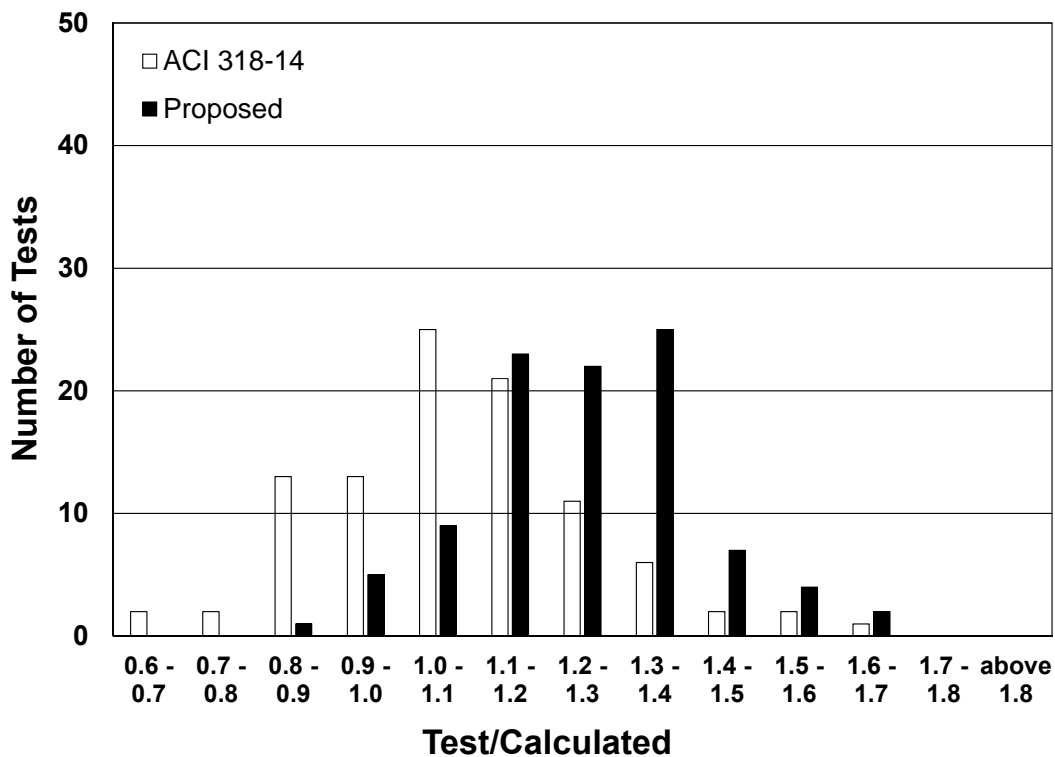

Figure 4.9 Test-to-calculated strength ratios T/T_h for ACI 318-14 and proposed provisions for specimens with two widely-spaced hooked bars without confining reinforcement

Figure 4.10 shows the distribution of the test-to-calculated strength ratios T/T_h for specimens with two widely-spaced hooked bars with confining reinforcement based on ACI 318-14 and on the proposed design provisions. Like Figure 4.10, values of T/T_h exhibit less scatter

when the proposed provisions than when using those in ACI 318-14. Twenty-two percent of the test-to-calculated strength ratios for ACI 318-14 design fall below 1.0, compared to 6% for the proposed equation.

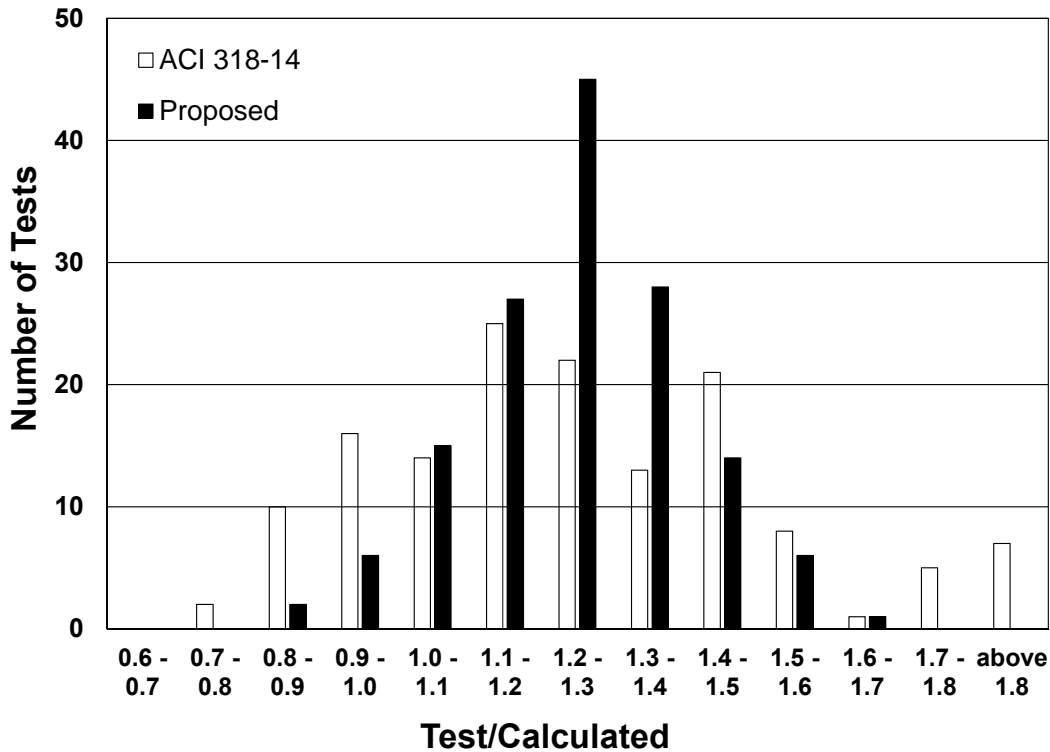

Figure 4.10 Test-to-calculated strength ratios T/T_h for ACI 318-14 and proposed provisions for specimens with two widely-spaced hooked bars with confining reinforcement

Table 4.4 summarizes the maximum, minimum, mean, standard deviation, and coefficient of variation of the test-to-calculated strength ratios for the specimens with two widely-spaced hooked bars without and with confining reinforcement used in developing the proposed design equation, Eq. (4.11), along with the number of specimens with test-to-calculated strength ratios below 1.0. The table shows that the proposed equation has a much lower coefficient of variation for specimens both with and without confining reinforcement and, as shown in Figures 4.9 and 4.10, lower numbers of specimens with test-to-calculated strength ratio below 1.0. It also shows

that for ACI 318-14, Eq. (4.12), the mean value of T/T_h is just 1.08 for specimens without confining reinforcement.

Table 4.4 Statistical parameters of the test-to-calculated strength ratio T/T_h for specimens with two widely-spaced hooked bars shown in Figures 4.9 and 4.10

(No. of specimens)	Specimens without confining reinforcement (99)		Specimens with confining reinforcement (146)	
	Using ACI 318-14 Equation	Using Proposed Equation	Using ACI 318-14 Equation	Using Proposed Equation
Maximum	1.643	1.653	1.886	1.601
Minimum	0.675	0.895	0.758	0.824
Mean	1.084	1.246	1.249	1.245
Standard Deviation	0.186	0.155	0.262	0.151
Coefficient of Variation	0.171	0.124	0.209	0.122
No. with $T/T_h < 1.0$	30	6	32	8

Table 4.5 shows the statistical parameters of the test-to-calculated strength ratio T/T_h for the specimens with hooked bars placed outside the column core, specimens with closely-spaced hooked bars extended halfway through the column depth, and wall specimens. Specimens with closely-spaced hooked bars extended just halfway through the column depth were included with the specimens placed outside the column core since the same modification factor, ψ_o , is applied for both.

The table shows that when using the design provisions in ACI 318-14, the mean test-to-calculated strength ratio is 1.10 for specimens with closely-spaced hooked bars with confining reinforcement, and as low as 0.87 for specimens with hooked bars placed outside the column core or extended halfway through the column depth without confining reinforcement. For the proposed design provisions, the lowest mean is 1.24, for specimens with closely-spaced hooked bars without confining reinforcement, and the highest mean is 1.34, for specimens outside column core or extended halfway through the column depth with confining reinforcement. The proposed equation

has a lower coefficient of variation compared to ACI 318-14, except when the hooked bars are embedded in walls, where the two COVs are the same but the mean for ACI 318-14 is about 40% higher than the mean calculated using the proposed equation. Except for hooked bars embedded in walls, the number of specimens with a test-to-calculated strength ratio below 1.0 is always higher when using ACI 318-14.

Table 4.5 Statistical parameters of the test-to-calculated strength ratio T/T_h for specimens with closely-spaced hooked bars, with hooked bars outside column core, and hooked bars extended halfway through column depth

	Specimens without confining reinforcement		Specimens with confining reinforcement	
	Using ACI 318-14 Equation	Using Proposed Equation	Using ACI 318-14 Equation	Using Proposed Equation
Specimens with closely-spaced hooked bars				
Number of Specimens	15		25	
Maximum	1.41	1.44	1.80	1.49
Minimum	0.70	1.05	0.75	0.89
Mean	0.94	1.24	1.10	1.18
Standard Deviation	0.19	0.13	0.29	0.16
Coefficient of Variation	0.20	0.11	0.27	0.13
No. with $T/T_h < 1.0$	11	0	10	3
Specimens with hooked bars outside the column core or extended halfway through column depth				
Number of Specimens	29		32	
Maximum	1.89	1.76	2.46	1.88
Minimum	0.32	0.79	0.51	0.86
Mean	0.87	1.33	1.08	1.34
Standard Deviation	0.44	0.24	0.47	0.28
Coefficient of Variation	0.51	0.18	0.43	0.21
No. with $T/T_h < 1.0$	20	2	15	5
Specimens with hooked bars embedded in walls				
Number of Specimens	30		0	
Maximum	2.56	1.76	---	---
Minimum	1.34	0.84	---	---
Mean	1.83	1.31	---	---
Standard Deviation	0.34	0.24	---	---
Coefficient of Variation	0.19	0.19	---	---
No. with $T/T_h < 1.0$	0	4	---	---

4.5 PROPOSED CODE PROVISIONS

This section presents the proposed provisions for incorporation in the ACI 318 Building Code. The section numbers in ACI 318-14 are used. The factors for epoxy-coated bars, lightweight concrete, and minimum development length criteria are the same as used in the current code.

25.4.1.4 The values of f_c' used to calculate development length shall not exceed 10,000 psi, except as permitted in 25.4.3.1(a)

25.4.3 *Development of standard hooks in tension*

25.4.3.1 Development length ℓ_{dh} for deformed bars in tension terminating in a standard hook shall be the greater of (a) through (c):

(a) $\ell_{dh} = \left(0.0018 \frac{f_y \Psi_e \Psi_r \Psi_m \Psi_o}{\lambda f_c'^{0.25}} \right) d_b^{1.5}$ with Ψ_e , Ψ_r , Ψ_m , Ψ_o , and λ given in 25.4.3.2; the value of f_c' shall not exceed 16,000 psi.

(b) $8d_b$

(c) 6 in.

25.4.3.2 For the calculation of ℓ_{dh} , modification factors shall be in accordance with Table 25.4.3.2a. The factor Ψ_r shall be permitted to be taken as 1.0. At discontinuous ends of members, 25.4.3.3 shall apply.

Table 25.4.3.2a—Modification factors for development of hooked bars in tension

Modification Factor	Condition	Value of factor
Lightweight λ	Lightweight concrete	0.75
	Normalweight concrete	1.0
Epoxy Ψ_e	Epoxy-coated or zinc and epoxy dual-coated reinforcement	1.2
	Uncoated or zinc-coated (galvanized) reinforcement	1.0
Placement Ψ_o	For No. 11 bar and smaller hooks (1) terminating at the far face of a column core with side cover (normal to plane of hook) ≥ 2.5 in., or (2) terminating in a wall with cover on the bar extension beyond hook $< 0.2 \times$ wall thickness h and with side cover (normal to plane of hook) $\geq 7d_b$	1.0
	Other	1.25
Closely spaced hooked bars $\Psi_m^{[2]}$	For hooked bars spaced $< 7d_b$ with no confining reinforcement	$\left(0.085 \frac{c_{ch}}{d_b} + 0.42\right)^{-1} \geq 1.0^{[1]}$
	For hooked bars spaced $< 7d_b$ with confining reinforcement and NA_t/n of 0.22	$\left(0.035 \frac{c_{ch}}{d_b} + 0.74\right)^{-1} \geq 1.0$
	Other	1.0
Confining reinforcement Ψ_r	For No. 11 or smaller hooked bars with confining reinforcement parallel to the straight portion of bar	$\Psi_r = \frac{f_y d_b^{1.5} - 48,900 NA_t/n}{f_y d_b^{1.5}} \geq 0.7^{[3]}$
	For No. 11 or smaller hooked bars with confining reinforcement perpendicular to the straight portion of bar	$\Psi_r = \frac{f_y d_b^{1.5} - 1,330 f_c^{0.25} NA_t/n}{f_y d_b^{1.5}} \geq 0.7$

^[1] c_{ch} is the center-to-center spacing of hooked bars.

^[2] Linear interpolation between the two equations can be done for values of NA_t/n between 0 and 0.22

^[3] f_y is the yield strength and d_b is the nominal diameter of the hooked bars, N is the number of legs of transverse reinforcement confining hooks – based on dimensions of 180° hooks, n is the number of hooked bars being developed.

25.4.3.3 For bars being developed by a standard hook at discontinuous ends of members with both side cover and top (or bottom) cover to hook less than 2-½ in., (a) through (d) shall be satisfied:

(a) The hook shall be enclosed along ℓ_{dh} within ties or stirrups perpendicular to ℓ_{dh} at $s \leq 3d_b$

(b) The first tie or stirrup shall enclose the bent portion of the hook within $2d_b$ of the outside of the bend

(c) Ψ_r shall be taken as 1.0 in calculating ℓ_{dh} in accordance with 25.4.3.1(a)

(d) Ψ_o shall be taken as 1.25 in calculating ℓ_{dh} in accordance with 25.4.3.1(a)

where d_b is the nominal diameter of the hooked bar.

4.6 SUMMARY AND CONCLUSIONS

4.6.1 Summary

In this chapter, hooked bar design provisions are proposed to replace the existing ACI 318-14 hooked bar design provisions, incorporating the results of an extensive experimental study on hooked bars by Sperry et al. (2015a)Sperry et al. (2015a). A reliability-based design expression suggested by Sperry et al. (2015b) was modified to obtain the final design expression. Modification factors are proposed to account for the effects of hooked bar spacing for closely-spaced hooked bars up to $7d_b$ and the effect of placing the hooked bars outside the column core or when not extended to the far side of the column, where both modification factors increase the calculated embedment length using the expression suggested by Sperry et al. (2015b). In the proposed design provisions, the current limitations on concrete compressive strength are expanded to include concrete compressive strengths up to 16,000 psi (110 MPa), and the limit on the specified yield strength of the reinforcing steel is extended from Grade 80 (550 MPa) to Grade 120 (830 MPa). The suggested expression and the current equation used by ACI 318-14 for hooked bar design were evaluated using the results of 245 beam-column joint test results. Proposed code language, similar to that in the ACI 318-14 hooked bar design provisions, is provided.

4.6.2 Conclusions

The following conclusions are based on the results and analysis presented in this chapter.

1. The proposed development length design expression with the spacing modification factor accounts for the spacing effect between hooked bars.
2. The development length modification factor of 1.25 accounts for lower anchorage strength resulting from placing hooked bars outside the column core or not extending hooked bars to the back of the column.
3. Hooked bars not in a beam-column joint with side cover more than $7d_b$ behave similarly to those inside the column core of a beam-column joint, and can use a location modification factor $\psi_o = 1.0$.
4. The proposed design provisions show better correlation with the experimental results and less scatter than those in ACI 318-14.

4.7 REFERENCES

AASHTO, *AASHTO LRFD Bridge Design Specifications*, 2012, 6th edition, American Association of State Highway and Transportation Officials, 1672 pp.

ACI Committee 318, 2014, "Building Code Requirements for Structural Concrete (ACI 318-14)," American Concrete Institute, Farmington Hills, MI, 518 pp.

Hamad, B. S., Jirsa, J. O., and d'Abreu d Paolo, N. I., 1993, "Anchorage Strength of Epoxy-Coated Hooked Bars," *ACI Structural Journal*, Vol. 90, No. 2, Mar.-Apr., pp. 210-217.

Johnson, L. A. and Jirsa, J. O., 1981, "The Influence of Short Embedment and Close Spacing on the Strength of Hooked Bar Anchorages," *No. 81-2*, University of Texas, Structures Research Laboratory, Austin, TX, 93 pp.

Lee, J. and Park, H., 2010, "Bending - Applicability Study of Ultra-Bar (SD 600) and Ultra-Bar for Rebar Stirrups and Ties (SD 500 and 600) for Compression Rebar," [*Translated from Korean*] *Korea Concrete Institute*, Aug. , pp. 504.

Marques, J. L. G. and Jirsa, J. O., 1975, "A Study of Hooked Bar Anchorages in Beam-Column Joints," *ACI Journal, Proceedings*, Vol. 72, No. 5, May, pp. 198-209.

Pinc, R. L., Watkins, M. D., and Jirsa, J. O., 1977, "Strength of Hooked Bar Anchorages in Beam-Column Joints," 77-3, University of Texas, Austin, TX, 67 pp.

Ramirez, J. A. and Russell, B. W., 2008, "Transfer, Development, and Splice Length for Strand/reinforcement in High-strength Concrete," Transportation Research Board, National Research Council, Washington, D.C., 99-120 pp.

Sperry, J., Al-Yasso, S., Searle, N., DeRubeis, M., Darwin, D., O'Reilly, M., Matamoros, A., Feldman, L., Lepage, A., Lequesne, R., and Ajaam, A., 2015a, "Anchorage of High-Strength Reinforcing Bars With Standard Hooks," *SM Report No. 111*, The University of Kansas Center for Research, Lawrence, KS, 260 pp.

Sperry, J., Darwin, D., O'Reilly, M., and Lequesne, R., 2015b, "Anchorage Strength of Conventional and High-Strength Hooked Bars in Concrete," *SM Report No. 115*, The University of Kansas Center for Research, Lawrence, KS, 281 pp.

Sperry, J., Yasso, S., Searle, N., DeRubeis, M., Darwin, D., O'Reilly, M., Matamoros, A., Feldman, L., Lepage, A., Lequesne, R., and Ajaam, A., 2017a, "Conventional and High-Strength Hooked Bars—Part 1: Anchorage Tests," *ACI Structural Journal*, Vol. 114, No. 1, Jan.-Feb. 2017, pp. 255-266.

Sperry, J., Darwin, D., O'Reilly, M., Lequesne, R., Yasso, S., Matamoros, A., Feldman, L., and Lepage, A., 2017b, "Conventional and High-Strength Hooked Bars—Part 2: Data Analysis," *ACI Structural Journal*, Vol. 114, No. 1, Jan.-Feb. 2017, pp. 267-276.

CHAPTER 5: SUMMARY AND CONCLUSIONS

5.1 SUMMARY

This study uses results of 338 simulated beam-column joint specimen tests at the University of Kansas, including two, three, or four No. 5, 8, or 11 (No. 16, 25, or 36) hooked bars with 90° or 180° hooks, along with 61 tests by others to investigate the effects of hooked bar spacing, anchoring the hooked bars outside the column core or halfway through the column depth, concrete tail cover to 90° hooks, and the effect of tail kickout at failure on hooked bar anchorage strength. The 61 tests by others include 31 of simulated beam-column joint specimens and 30 simulated slab-to-wall connections. The specimens at the University of Kansas contained two, three, or four No. 5, 8, and 11 (No. 16, 25, and 36) hooked bars with 90° or 180° hooks. For beam-column joint specimens, center-to-center spacing between hooked bars ranged from 3 to 12 bar diameters, with the majority of values between $10d_b$ and $12d_b$. Hooked bars had nominal embedment lengths ranging from 2.5 to 25.2 in. (64 to 640 mm), nominal concrete side cover ranging from 1.5 to 4 in. (38 to 100 mm) in simulated beam-column joints and 11.3 to 24.6 in. (287 to 625 mm) in walls, and nominal concrete tail cover to the hook ranging from 2 to 18 in. (50 to 460 mm). Concrete compressive strength ranged from 4,300 to 16,510 psi (30 to 114 MPa) in simulated beam-column joints and 2,400 to 5,450 psi (17 to 38 MPa) in walls, and bar stresses at anchorage failure ranged from 27,100 to 141,000 psi (187 to 972 MPa) in simulated beam-column joints and 14,200 to 60,000 psi (98 to 420 MPa) in walls. Hooked bars were placed inside or outside the column core, extended to the far side of the column or extended halfway through the column depth. Within the joint region, the specimens contained no confinement, 1 No. 3 (No. 10) hoop, 2 No. 3 (No. 10) hoops, 1 No. 4 (No. 12) hoops, 2 No. 4 (No. 12) hoops, 4 No. 3 (No. 10) hoops, and No. 3 (No. 10) hoops spaced at $3d_b$, the latter confinement qualifying for a 0.8 reduction in development

length in accordance with Section 25.4.3.2 of ACI 318-14. This study is part of a larger study that investigated the effect of different parameters on hooked bar anchorage strength. A subset consisting of 214 specimens containing two widely-spaced hooked bars from the current study and 31 specimens from studies by Marques and Jirsa (1975), Pinc et al. (1977), Hamad et al. (1993), Ramirez and Russell (2008), and Lee and Park (2010) was used by Sperry et al. (2015b, 2017b) to develop a descriptive equation for hooked bar anchorage strength. The descriptive equation was used to develop a reliability-based design expression for hooked bar development length. The current study investigated the effect of spacing between hooked bars, bars anchored outside of the beam-column joint, concrete tail cover to the hook, and tail kickout at failure. Based on the analyses of those results, the descriptive and design expression were extended to include the effects of hooked bar spacing, placing the hooked bar outside column core, and not extending the bar to the back of the column. Design provisions for hooked bars are proposed for incorporation in ACI 318 Building Code.

5.2 CONCLUSIONS

Based on the current study, the following conclusions are drawn:

1. Front failure was the dominant failure mode for specimens containing more than two hooked bars.
2. The anchorage strength of hooked bars in joints with three or four bars decreased for values of center-to-center spacing below seven bar diameters. The addition of confining reinforcement mitigated but did not eliminate this effect.
3. The modification to the descriptive equation by Sperry et al. (2015b, 2017b) to calculate the anchorage strength of two widely-spaced hooked bars to account for the effect of low

spacing between hooked bars provides a reasonable representation of the anchorage strength of closely-spaced hooked bars.

4. As the force per bar decreased as the number of bars within a given width increased, the total anchorage force for the hooked bars in the simulated beam-column joints remained constant or increased moderately as the number of hooked bars increased.
5. Placing hooked bars outside the column core results in a significantly lower anchorage strength than placing hooked bars inside the column core. In this study, the reduction ranged from 4 to 34%, producing an average anchorage strength equal to about 84% of the average strength of hooked bars placed inside the column core.
6. For hooked bars are placed outside the column core, the dominant failure mode was front failure for No. 5 (No. 16) bars and side failure for No. 8 and No. 11 (No. 25 and No. 36) hooked bars.
7. Hooked bars anchored halfway through the column depth exhibit reductions in anchorage strength compared to those anchored at the far side of the column, with front failure as the dominant mode of failure for all specimens.
8. Hooked bars extended to the far side of the column in simulated beam-columns joints exhibit reduced strength where the ratio of effective depth to the embedment length is greater than 1.5 compared to specimens where the ratio of effective depth to the embedment length less than 1.5.
9. The anchorage strength of hooked bars with a 90° bend angle is not affected by tail kickout at failure or hook tail covers as low as 0.75 in. (19 mm). The likelihood of tail kickout

increases with increasing bar size and for hooks with tail cover less than 2 in. (50 mm) and no confining reinforcement.

10. The proposed descriptive equations for anchorage force and design expressions for development length that include the spacing modification factor account for the spacing effect between hooked bars.
11. A development length modification factor of 1.25 accounts for lower anchorage strength resulting from placing hooked bars outside the column core or not extending hooked bars to the back of the column.
12. Hooked bars not in a beam-column joint with side cover more than $7d_b$ behave similarly to those inside the column core of a beam-column joint.
13. The proposed design provisions show a better correlation with the experimental results and less scatter than those in ACI 318-14.

5.3 FUTURE WORK

Other variables will be investigated as part of this research program including testing more specimens with closely-spaced hooked bars and specimens with staggered bars (multiple rows). These tests will expand the existing database, and based on the tests, design modifications can be suggested to account for the effect of having closely-spaced and staggered bars.

APPENDIX A: NOTATION AND DATA TABLES USED IN CHAPTER 2

A_h	Bar area of hook
A_{tr}	Total area of transverse steel inside hook region
A_s	Area of longitudinal steel in the column
A_{cti}	Total area of cross-ties inside the hook region
b	Column width
c_b	Clear cover measured from the center of the hook to the side of the column
c_h	Clear spacing between hooked bars, inside-to-inside spacing
c_{so}	Clear cover measured from the side of the hook to the side of the column
$c_{so,avg}$	Average clear cover of the hooked bars
c_{th}	Clear cover measured from the tail of the hook to the back of the column
d_b	Nominal bar diameter of the hooked bar
d_{cto}	Nominal bar diameter of cross-ties outside the hook region
d_{tr}	Nominal bar diameter of transverse reinforcement inside the hook region
d_{s_o}	Nominal bar diameter of transverse reinforcing steel outside the hook region
f_c	Specified concrete compressive strength
f_{cm}	Measured average concrete compressive strength
$f_{s,ACI}$	Stress in hook as calculated by Section 25.4.3.1 of ACI 318-14
$f_{su,ind}$	Stress in hook at failure
f_{su}	Average peak stress in hooked bars at failure
f_{yt}	Nominal yield strength of transverse reinforcement
f_{ys}	Nominal yield strength of longitudinal reinforcing steel in the column
h_c	Width of bearing member flange
h_{cl}	Height measured from the center of the hook to the top of the bearing member flange
h_{cu}	Height measured from the center of the hook to the bottom of the upper compression member
ℓ_{eh}	Embedment length measured from the back of the hook to the front of the column
$\ell_{eh,avg}$	Average embedment length of hooked bars
n	Number of hooked bars confined by N legs
N	Number of legs of confining reinforcement in joint region
N_{cti}	Total number of cross-ties used as supplemental reinforcement inside the hook region
N_{cto}	Number of cross-ties used per layer as supplemental reinforcement outside the hook region and spaced at s_s
N_h	Number of hooked bars loaded simultaneously
N_{tr}	Number of stirrups/ties crossing the hook
T	Average peak load on hooked bars
T_c	Contribution of concrete to hooked bar anchorage capacity
T_{ind}	Peak load on the hooked bar at failure
T_h	Hooked bar anchorage strength
T_s	Contribution of confining steel in joint region to hooked bar anchorage strength
T_{max}	Maximum load on individual hooked bar
T_{total}	Sum of the loads on hooked bars at failure
T_N	Load on hooked bar at failure multiplied by concrete compressive strength normalized to 5,000 psi
R_r	Relative rib area
s_{cti}	Center-to-center spacing of cross-ties in the hook region
s_{tr}	Center-to-center spacing of transverse reinforcement in the hook region
s_s	Center-to-center spacing of stirrups/ties outside the hook region

α	Student's t-test significance
ψ_e	Epoxy coating factor as defined in ACI 318-14 Section 25.4.3.2
ψ_c	Factor for cover as defined in ACI 318-14 Section 25.4.3.2
ψ_r	Factor for transverse reinforcement in the hook region
ψ_o	Factor for hooked bar location
ψ_m	Hooked bar spacing factor

Failure types

FF	Front Failure
SF	Side Failure
TK	Tail Kickout
FL	Flexural Failure of column
BY	Yield of hooked bars

Specimen identification

(A@B) C-D-E-F#G-H-I-J-Kx(L)

A	Number of hooks in the specimen
B	Clear spacing between hooks in terms of bar diameter (A@B = blank, indicates standard 2-hook specimen)
C	ASTM in.-lb bar size
D	Nominal compressive strength of concrete
E	Angle of bend
F	Number of bars used as transverse reinforcement within the hook region
G	ASTM in.-lb bar size of transverse reinforcement (if D#E = 0 = no transverse reinforcement)
H	Hooked bars placed inside (i) or outside (o) of longitudinal reinforcement
I	Nominal value of c_{so}
J	Nominal value of c_{th}
K	Nominal value of ℓ_{eh}
x	Replication in a series, blank (or a), b, c, etc.
L	Replication not in a series

LONGITUDINAL COLUMN STEEL LAYOUTS

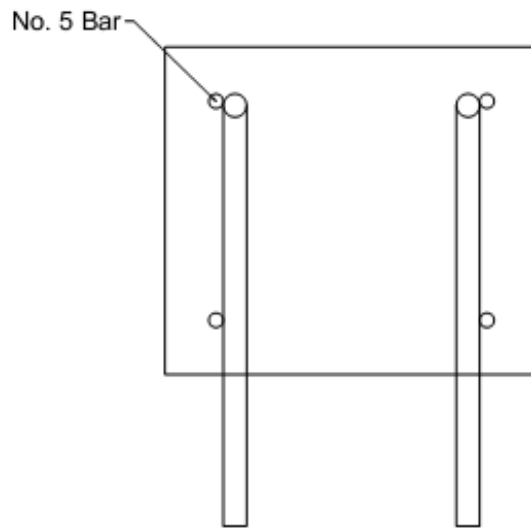

Figure A.1 Longitudinal column reinforcement-4 No. 5 bars. Transverse reinforcement not shown.

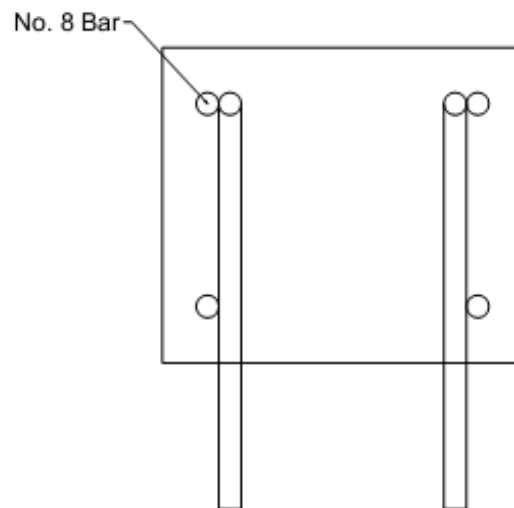

Figure A.2 Longitudinal column reinforcement-4 No. 8 bars. Transverse reinforcement not shown.

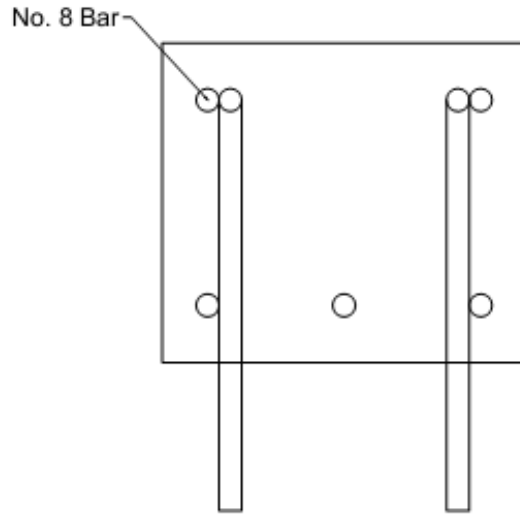

Figure A.3 Longitudinal column reinforcement-5 No. 8 bars. Transverse reinforcement not shown.

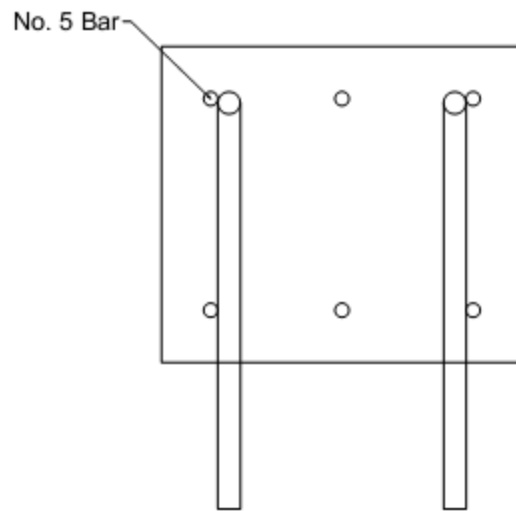

Figure A.4 Longitudinal column reinforcement-6 No. 5 bars. Transverse reinforcement not shown.

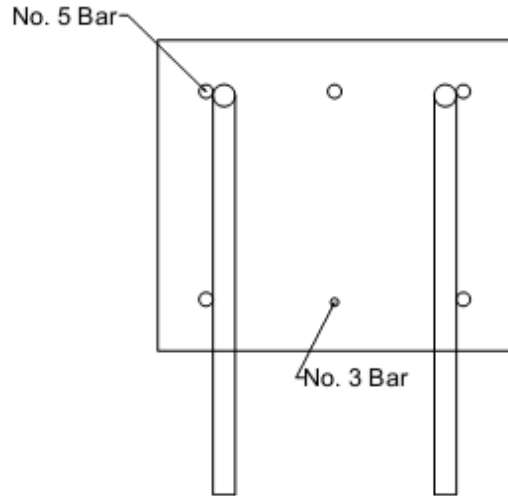

Figure A.5 Longitudinal column reinforcement-5 No. 5 bars + 1 No. 3 bar. Transverse reinforcement not shown.

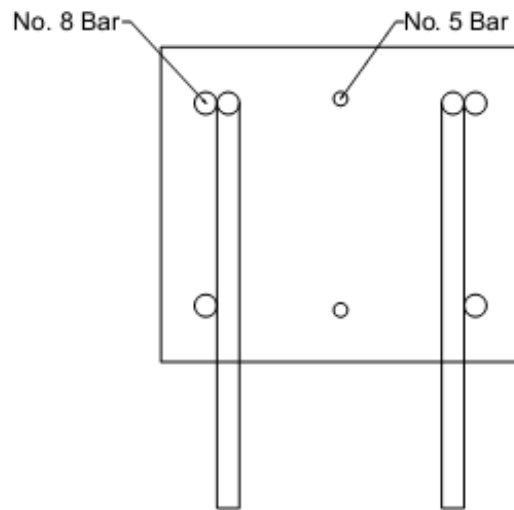

Figure A.6 Longitudinal column reinforcement-4 No. 8 bars + 2 No. 5 bars. Transverse reinforcement not shown.

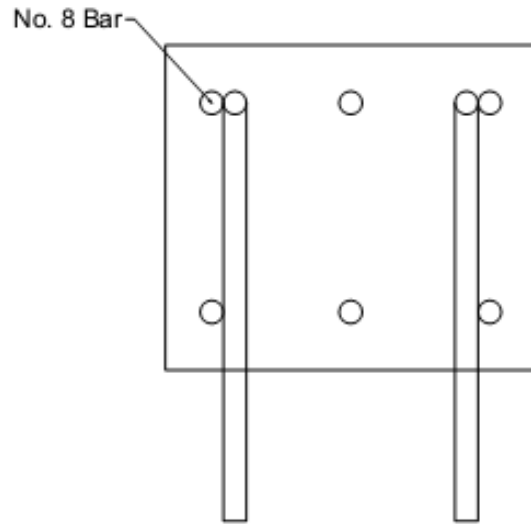

Figure A.7 Longitudinal column reinforcement-6 No. 8 bars. Transverse reinforcement not shown.

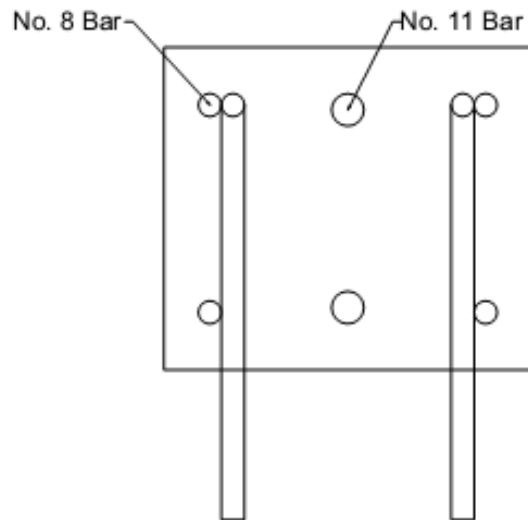

Figure A.8 Longitudinal column reinforcement-4 No. 8 bars + 2 No. 11 bars. Transverse reinforcement not shown.

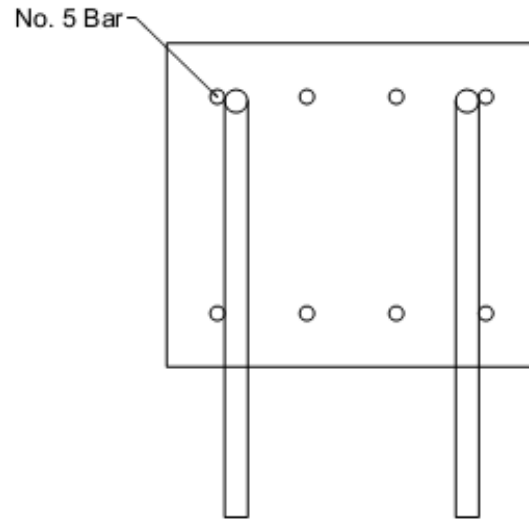

Figure A.9 Longitudinal column reinforcement-8 No. 5 bars. Transverse reinforcement not shown.

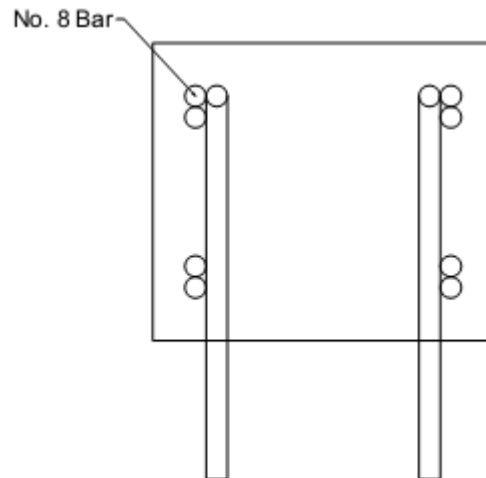

Figure A.10 Longitudinal column reinforcement-8 No. 8 bars (four bundles of two bars each). Transverse reinforcement not shown.

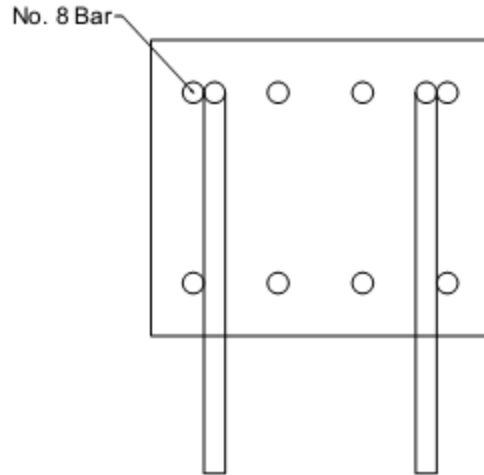

Figure A.11 Longitudinal column reinforcement-8 No. 8 bars (distributed across two column faces). Transverse reinforcement not shown.

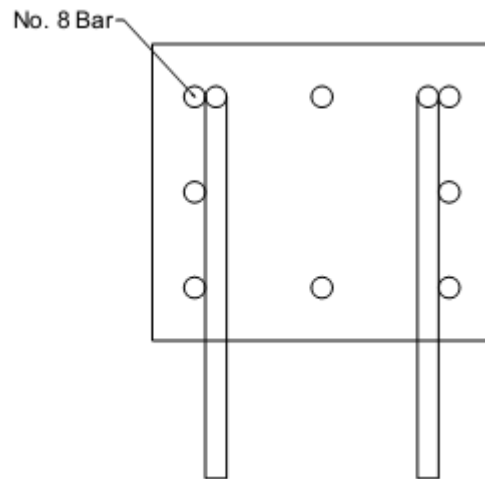

Figure A.12 Longitudinal column reinforcement-8 No. 8 bars (distributed across four column faces). Transverse reinforcement not shown.

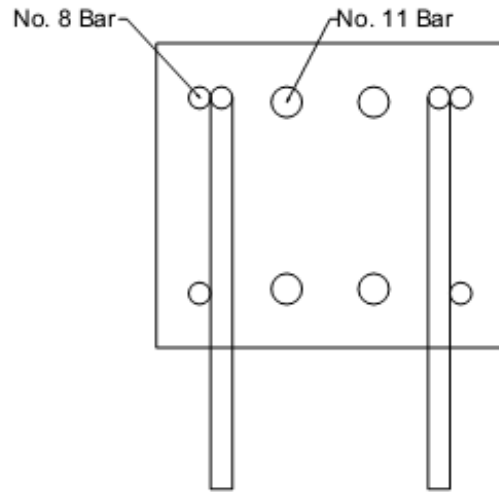

Figure A.13 Longitudinal column reinforcement-4 No. 8 bars + 4 No. 11 bars. Transverse reinforcement not shown.

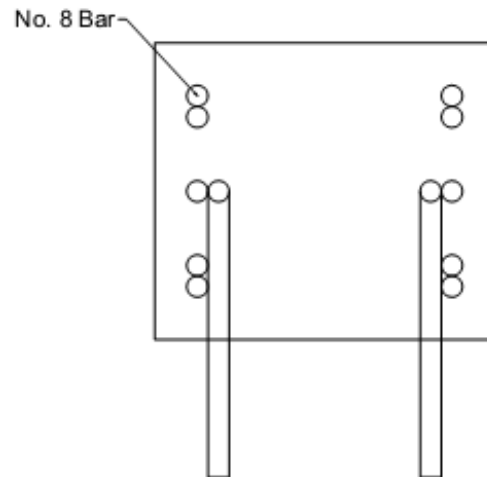

Figure A.14 Longitudinal column reinforcement-10 No. 8 bars. Transverse reinforcement not shown.

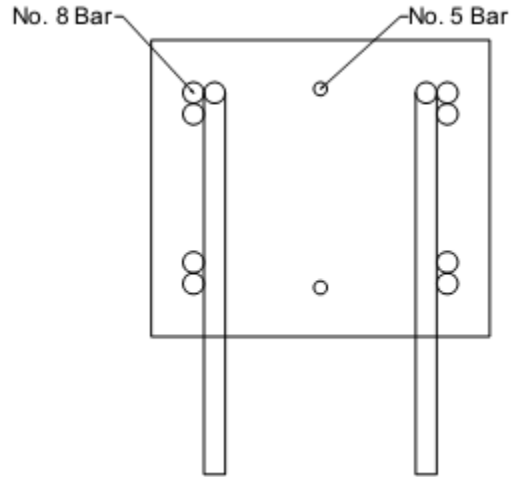

Figure A.15 Longitudinal column reinforcement-8 No. 8 bars + 2 No. 5 bars. Transverse reinforcement not shown.

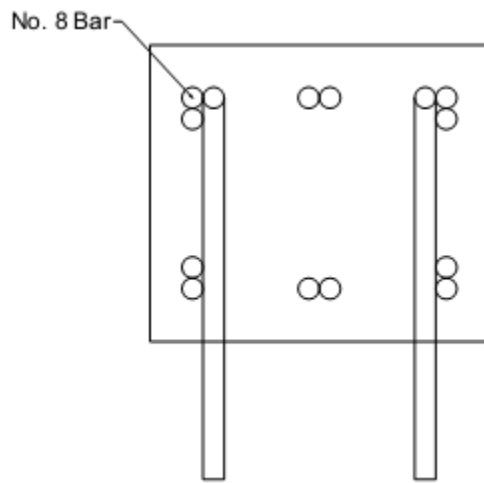

Figure A.16 Longitudinal column reinforcement-12 No. 8 bars. Transverse reinforcement not shown.

Table A.1 Comprehensive test results and data for No. 5 specimens with two hooks

	Specimen	Hook	Bend Angle	Trans. Reinf. Orient.	Hook Bar Type	ℓ_{ch} in.	$\ell_{ch,avg}$ in.	f'_c psi	Age days	d_b in.
1	5-5-90-0-o-1.5-2-5	A B	90°	Para	A615	5.0 5.0	5.0	4930	4	0.625
2	5-5-90-0-o-1.5-2-6.5	A B	90°	Para	A1035	6.5 5.9	6.2	5650	6	0.625
3	5-5-90-0-o-1.5-2-8	B	90°	Para	A1035	7.9	7.9	5650	6	0.625
4	5-5-90-0-o-2.5-2-5	A B	90°	Para	A615	4.8 4.8	4.8	4930	4	0.625
5	5-5-90-0-o-2.5-2-8	A	90°	Para	A1035	9.0	9.0	5780	7	0.625
6	5-5-180-0-o-1.5-2-9.5	A B	180°	Para	A1035	9.6 9.3	9.4	4420	7	0.625
7	5-5-180-0-o-1.5-2-11.25	A	180°	Para	A1035	11.3	11.3	4520	8	0.625
8	5-5-180-0-o-2.5-2-9.5	A B	180°	Para	A1035	9.5 9.5	9.5	4520	8	0.625
9	5-5-90-0-i-2.5-2-10	A B	90°	Para	A1035	9.4 9.4	9.4	5230	6	0.625
10	5-5-90-0-i-2.5-2-7	A B	90°	Para	A1035	6.9 7.0	6.9	5190	7	0.625
11	5-8-90-0-i-2.5-2-6	A B	90°	Para	A615	6.8 6.8	6.8	8450	14	0.625
12	5-8-90-0-i-2.5-2-6(1)	A B	90°	Para	A1035	6.1 6.5	6.3	9080	11	0.625
13	5-8-90-0-i-2.5-2-8	A B	90°	Para	A1035	8.0 7.5	7.8	8580	15	0.625
14	(2@4) 5-8-90-0-i-2.5-2-6	A B	90°	Para	A1035	5.8 6.0	5.9	6950	18	0.625
15	(2@6) 5-8-90-0-i-2.5-2-6	A B	90°	Para	A1035	6.0 6.0	6.0	6950	18	0.625
16	5-12-90-0-i-2.5-2-10	A B	90°	Para	A1035	10.0 11.0	10.5	10290	14	0.625
17	5-12-90-0-i-2.5-2-5	A B	90°	Para	A1035	5.1 4.8	4.9	11600	84	0.625
18	5-15-90-0-i-2.5-2-5.5	A B	90°	Para	A1035	6.1 5.8	5.9	15800	62	0.625
19	5-15-90-0-i-2.5-2-7.5	A B	90°	Para	A1035	7.3 7.3	7.3	15800	62	0.625
20	5-5-90-0-i-3.5-2-10	A B	90°	Para	A1035	10.5 10.4	10.4	5190	7	0.625
21	5-5-90-0-i-3.5-2-7	A B	90°	Para	A1035	7.5 7.6	7.6	5190	7	0.625
22	5-8-90-0-i-3.5-2-6	A B	90°	Para	A615	6.3 6.4	6.3	8580	15	0.625
23	5-8-90-0-i-3.5-2-6(1)	A B	90°	Para	A1035	6.5 6.6	6.6	9300	13	0.625
24	5-8-90-0-i-3.5-2-8	A B	90°	Para	A1035	8.6 8.5	8.6	8380	13	0.625
25	5-12-90-0-i-3.5-2-5	A B	90°	Para	A1035	5.5 5.4	5.4	10410	15	0.625
26	5-12-90-0-i-3.5-2-10	A B	90°	Para	A1035	10.1 10.0	10.1	11600	84	0.625

Table A.1 Cont. Comprehensive test results and data for No. 5 specimens with two hooks

	Hook	R_r	b in.	h in.	h_{cl} in.	h_c in.	c_{so} in.	$c_{so,avg}$ in.	c_{th} in.	c_h in.	N_h	Axial Load kips	Long. Reinf. Layout ^o
1	A B	0.077	11.3	7.0	5.25	8.375	1.5 1.8	1.6	2.0 2.0	6.8	2	80	A1
2	A B	0.073	11.0	8.6	5.25	8.375	1.5 1.6	1.6	2.0 2.8	6.6	2	80	A4
3	B	0.073	11.9	10.0	5.25	8.375	1.5	1.5	2.1	6.6	2	80	A1
4	A B	0.077	12.6	6.9	5.25	8.375	2.5 2.5	2.5	2.1 2.1	6.4	2	80	A1
5	A	0.073	12.1	10.8	5.25	8.375	2.6	2.6	1.5	6.6	2	80	A1
6	A B	0.077	10.9	11.6	5.25	8.375	1.6 1.6	1.6	2.1 2.1	6.4	2	80	A1
7	A	0.077	11.4	13.3	5.25	8.375	1.8	1.8	2.3	6.6	2	80	A1
8	A B	0.077	12.9	11.3	5.25	8.375	2.5 2.5	2.5	1.9 1.8	6.6	2	80	A4
9	A B	0.073	13.1	12.3	5.25	8.375	2.8 2.6	2.7	2.9 2.9	6.4	2	30	A4
10	A B	0.073	13.0	9.6	5.25	8.375	2.5 2.5	2.5	2.8 2.6	6.8	2	30	A1
11	A B	0.073	13.0	8.0	5.25	8.375	2.8 2.6	2.7	1.3 1.3	6.4	2	80	A1
12	A B	0.073	13.3	8.8	5.25	8.375	2.5 2.5	2.5	2.6 2.3	7.0	2	30	A1
13	A B	0.073	13.1	10.0	5.25	8.375	2.5 2.8	2.6	2.0 2.5	6.6	2	80	A1
14	A B	0.073	9.5	8.0	5.25	8.375	2.7 3.7	3.2	2.3 2.0	1.9	2	30	A2
15	A B	0.073	9.6	8.0	5.25	8.375	2.6 2.7	2.6	2.0 2.0	3.1	2	30	A2
16	A B	0.073	12.8	12.5	5.25	8.375	2.4 2.5	2.4	2.5 1.5	6.6	2	30	A4
17	A B	0.073	13.0	7.3	5.25	8.375	2.6 2.6	2.6	2.1 2.5	6.5	2	30	A1
18	A B	0.073	12.6	7.7	5.25	8.375	2.4 2.4	2.4	1.6 1.9	6.6	2	30	A1
19	A B	0.073	12.9	9.8	5.25	8.375	2.5 2.5	2.5	2.6 2.6	6.6	2	30	A2
20	A B	0.073	14.8	12.3	5.25	8.375	3.5 3.5	3.5	1.8 1.9	6.5	2	30	A4
21	A B	0.073	15.1	8.8	5.25	8.375	3.4 3.5	3.4	1.3 1.1	7.0	2	30	A1
22	A B	0.073	15.0	8.0	5.38	8.375	3.6 3.5	3.6	1.8 1.6	6.6	2	80	A1
23	A B	0.073	15.6	8.6	5.25	8.375	3.8 3.8	3.8	2.1 1.9	6.9	2	30	A1
24	A B	0.060	15.5	10.0	5.25	8.375	3.6 3.5	3.6	1.4 1.5	7.1	2	80	A1
25	A B	0.073	15.5	7.2	5.25	8.375	3.6 3.6	3.6	1.7 1.8	7.0	2	30	A1
26	A B	0.073	15.0	12.1	5.25	8.375	3.5 3.5	3.5	2.5 1.5	6.8	2	30	A4

^o Longitudinal column configurations shown in Appendix A, Figures A1 – A16

Table A.1 Cont. Comprehensive test results and data for No. 5 specimens with two hooks

	Hook	T_{max}	T_{ind}	T_{total}	T	$f_{su,max}$	f_{su}	$f_{s,ACI}$	Joint shear at failure/ $\sqrt{f_{cm}}$	Slip at Failure	Failure Type
		lb	lb	lb	lb	psi	psi	psi		in.	
1	A	14139	14029	28137	14069	45609	45382	40122	3.6	-	F/S
	B	19575	14108			63147				-	F/S
2	A	20758	17440	35627	17813	66962	57463	53261	3.5	-	F
	B	18187	18187			58667				-	F/S
3	B	23455	23455	23455	23455	75663	75663	67650	1.8	-	S
4	A	19559	19559	38566	19283	63094	62204	38116	4.4	-	F/S
	B	23982	19007			77362				-	F/S
5	A	30340	30340	30340	30340	97870	97870	78198	2.1	-	S
6	A	35211	28603	58973	29486	113585	95117	71707	4.9	-	F
	B	30370	30370			97968				-	F/S
7	A	32374	32374	32374	32374	104432	104432	86440	2.2	-	F/S
8	A	40406	40351	60255	30128	130342	97186	72994	4.3	-	F
	B	24657	19904			79538				-	F
9	A	37404	34303	67166	33583	120656	108333	77484	4.1	-	F/S
	B	32864	32864			106012				-	F/S
10	A	26607	26607	52529	26265	85831	84724	57119	4.1	-	F/S
	B	26095	25922			84176				0.192	F/S
11	A	27578	27102	59140	29570	88961	95387	70913	4.3	-	F/S
	B	32135	32038			103663				-	S/F
12	A	21741	21741	44849	22425	70131	72338	68744	2.8	0.296	F
	B	24995	23109			80630				.330(.030)	F
13	A	31878	31469	63347	31673	102831	102172	82042	3.6	-	S/F
	B	35934	31878			115915				-	S/F
14	A	23217	23089	44706	22353	74893	72106	55975	4.9	-	F
	B	21747	21617			70152				-	F
15	A	25504	25052	47902	23951	82272	77261	57166	5.2	-	F/S
	B	24013	22850			77463				-	F/S
16	A	40823	40823	83314	41657	131688	134377	121728	3.6	0.191	S
	B	42491	42491			137066				-	F/S/TK
17	A	19389	19389	38441	19220	62546	62001	60775	2.6	-	F/S
	B	23171	19051			74745				-	F
18	A	36163	32648	65021	32511	116656	104873	85295	3.7	-	F
	B	32373	32373			104430				-	F
19	A	42470	42464	84441	42221	137001	136196	104150	3.7	-	F
	B	41977	41977			135410				-	*
20	A	43228	43228	83855	41927	139446	135250	85935	4.5	-	S/F
	B	41140	40626			132710				-	S/F
21	A	27197	27197	53033	26516	87732	85537	62265	3.9	-	S
	B	25884	25836			83498				-	F/S
22	A	25129	25129	50950	25475	81060	82178	66825	3.2	-	F/S
	B	29054	25822			93723				-	F/S
23	A	24440	24440	49083	24541	78838	79166	72327	2.7	0.152	F/S
	B	27541	24643			88842				.178(.150)	F/S
24	A	39109	31179	65490	32745	126159	105629	89581	3.2	-	F/S
	B	34311	34311			110679				-	S
25	A	22045	22040	44241	22121	71114	71357	63404	2.7	-	F
	B	23158	22201			74702				-	F
26	A	46085	46016	90864	45432	148661	146556	123859	3.3	-	BY
	B	46076	44849			148631				-	BY

*Test terminated prior to failure of second hooked bar

Table A.1 Cont. Comprehensive test results and data for No. 5 specimens with two hooks

	Hook	f_{yt} ksi	d_{tr} in.	$A_{tr,l}$ in. ²	N_{tr}	s_{tr} in.	A_{cti} in. ²	N_{cti}	s_{cti} in.	d_s in.	s_s in.	d_{cto} in.	N_{cto}	A_s in. ²	f_{ys} ksi
1	A B	60	-	-	-	-	0.88	4 ¹	2.5	0.375	2.50	-	-	1.27	60
2	A B	60	-	-	-	-	0.88	4 ¹	2.5	0.375	2.50	-	-	1.89	60
3	B	60	-	-	-	-	0.88	4 ¹	2.5	0.375	2.50	-	-	1.27	60
4	A B	60	-	-	-	-	0.88	4 ¹	2.5	0.375	2.50	-	-	1.27	60
5	A	60	-	-	-	-	0.88	4 ¹	2.5	0.375	2.50	-	-	1.27	60
6	A B	60	-	-	-	-	0.22	1 ¹	4.0	0.375	4.00	-	-	1.27	60
7	A	60	-	-	-	-	0.22	1 ¹	4.0	0.375	4.0	-	-	1.27	60
8	A B	60	-	-	-	-	0.22	1 ¹	4.0	0.375	4.00	-	-	1.89	60
9	A B	60	-	-	-	-	0.33	3	3.0	0.375	3.00	-	-	1.89	60
10	A B	60	-	-	-	-	0.80	4	2.5	0.500	3.50	-	-	1.27	60
11	A B	60	-	-	-	-	0.80	4	4.0	0.500	4.00	-	-	1.27	60
12	A B	60	-	-	-	-	0.66	6	3.0	0.500	3.00	-	-	1.27	60
13	A B	60	-	-	-	-	0.80	4	4.0	0.500	4.00	-	-	1.27	60
14	A B	60	-	-	-	-	-	-	-	0.375	3.00	-	-	3.16	60
15	A B	60	-	-	-	-	-	-	-	0.375	3.00	-	-	3.16	60
16	A B	60	-	-	-	-	0.11	1	7.0	0.375	5.00	-	-	1.89	60
17	A B	60	-	-	-	-	0.66	6	2.5	0.500	3.00	-	-	1.27	60
18	A B	60	-	-	-	-	-	-	-	0.375	2.50	-	-	1.27	60
19	A B	60	-	-	-	-	-	-	-	0.375	3.50	-	-	3.16	60
20	A B	60	-	-	-	-	0.33	3	3.0	0.375	3.00	-	-	1.89	60
21	A B	60	-	-	-	-	0.80	4	2.5	0.375	3.50	-	-	1.27	60
22	A B	60	-	-	-	-	0.80	4	4.0	0.500	4.00	-	-	1.27	60
23	A B	60	-	-	-	-	0.66	6	3.0	0.500	3.00	-	-	1.27	60
24	A B	60	-	-	-	-	0.80	4	4.0	0.500	4.00	-	-	1.27	60
25	A B	60	-	-	-	-	0.66	6	2.5	0.500	3.00	-	-	1.27	60
26	A B	60	-	-	-	-	0.11	1	7.0	0.375	5.00	-	-	1.89	60

¹Specimen had full stirrups around the longitudinal bars in the hook region but not around the hooked bars

Table A.1 Cont. Comprehensive test results and data for No. 5 specimens with two hooks

	Specimen	Hook	Bend Angle	Trans. Reinf. Orient.	Hook Bar Type	ℓ_{eh} in.	$\ell_{eh,avg}$ in.	f'_c psi	Age days	d_b in.
27	5-8-180-0-i-2.5-2-7	A B	180°	Para	A1035	7.4 7.1	7.3	9080	11	0.625
28	5-8-180-0-i-3.5-2-7	A B	180°	Para	A1035	7.4 7.3	7.3	9080	11	0.625
29	5-5-90-1#3-i-2.5-2-8	A B	90°	Para	A1035	8.0 7.6	7.8	5310	6	0.625
30	5-5-90-1#3-i-2.5-2-6	A B	90°	Para	A615	4.8 5.5	5.1	5800	9	0.625
31	5-8-90-1#3-i-2.5-2-6	A B	90°	Para	A615	6.0 6.3	6.1	8450	14	0.625
32	5-8-90-1#3-i-2.5-2-6(1)	A B	90°	Para	A1035	6.1 5.6	5.9	9300	13	0.625
33	5-8-90-1#3-i-3.5-2-6	A B	90°	Para	A1035	6.0 6.0	6.0	8710	16	0.625
34	5-8-90-1#3-i-3.5-2-6(1)	A B	90°	Para	A1035	6.3 6.3	6.3	9190	12	0.625
35	5-5-180-1#3-i-2.5-2-8	A B	180°	Para	A1035	8.0 7.8	7.9	5670	7	0.625
36	5-5-180-1#3-i-2.5-2-6	A B	180°	Para	A615	6.0 6.0	6.0	5800	9	0.625
37	5-8-180-1#3-i-2.5-2-7	A B	180°	Para	A1035	7.1 7.3	7.2	9300	13	0.625
38	5-8-180-1#3-i-3.5-2-7	A B	180°	Para	A1035	7.1 6.8	6.9	9190	12	0.625
39	5-5-90-1#4-i-2.5-2-8	A B	90°	Para	A1035	7.4 7.8	7.6	5310	6	0.625
40	5-5-90-1#4-i-2.5-2-6	A B	90°	Para	A615	5.3 5.8	5.5	5860	8	0.625
41	5-8-90-1#4-i-2.5-2-6	A B	90°	Para	A1035	5.9 6.0	6.0	9300	13	0.625
42	5-8-90-1#4-i-3.5-2-6	A B	90°	Para	A1035	6.0 7.0	6.5	9190	12	0.625
43	5-5-180-1#4-i-2.5-2-8	A B	180°	Para	A1035	8.0 8.0	8.0	5310	6	0.625
44	5-5-180-1#4-i-2.5-2-6	A B	180°	Para	A615	6.5 6.0	6.3	5670	7	0.625
45	5-5-180-2#3-o-1.5-2-11.25	A B	180°	Para	A1035	11.6 11.5	11.6	4420	7	0.625
46	5-5-180-2#3-o-1.5-2-9.5	B	180°	Para	A1035	8.8	8.8	4520	8	0.625
47	5-5-180-2#3-o-2.5-2-9.5	A B	180°	Para	A1035	9.1 9.3	9.2	4420	7	0.625
48	5-5-180-2#3-o-2.5-2-11.25	A B	180°	Para	A1035	11.1 11.4	11.3	4520	8	0.625
49	5-5-90-2#3-i-2.5-2-8	A B	90°	Para	A1035	8.0 7.5	7.8	5860	8	0.625
50	5-5-90-2#3-i-2.5-2-6	A B	90°	Para	A615	6.0 5.8	5.9	5800	9	0.625
51	5-8-90-2#3-i-2.5-2-6	A B	90°	Para	A1035	6.0 6.0	6.0	8580	15	0.625
52	5-8-90-2#3-i-2.5-2-8	A B	90°	Para	A1035	8.3 8.5	8.4	8380	13	0.625

Table A.1 Cont. Comprehensive test results and data for No. 5 specimens with two hooks

	Hook	R_r	b in.	h in.	h_{cl} in.	h_c in.	c_{so} in.	$c_{so,avg}$ in.	c_{th} in.	c_h in.	N_h	Axial Load kips	Long. Reinf. Layout ^o
27	A B	0.073	12.6	9.5	5.25	8.375	2.5 2.6	2.6	2.1 2.4	6.3	2	30	A1
28	A B	0.073	15.4	9.3	5.25	8.375	3.6 3.4	3.5	1.9 2.0	7.1	2	30	A1
29	A B	0.073	13.1	10.4	5.25	8.375	2.5 2.5	2.5	2.4 2.8	6.9	2	80	A1
30	A B	0.060	13.1	8.0	5.25	8.375	2.5 2.5	2.5	3.3 2.5	6.9	2	80	A1
31	A B	0.060	12.9	8.0	5.25	8.375	2.5 2.5	2.5	2.0 1.8	6.6	2	80	A1
32	A B	0.073	13.1	8.3	5.25	8.375	2.6 2.8	2.7	2.1 2.6	6.5	2	30	A1
33	A B	0.060	15.3	8.0	5.25	8.375	3.6 3.6	3.6	2.0 2.0	6.8	2	80	A1
34	A B	0.073	15.3	8.6	5.25	8.375	3.8 3.5	3.6	2.4 2.4	6.8	2	30	A1
35	A B	0.073	13.0	10.3	5.25	8.375	2.6 2.5	2.6	2.3 2.5	6.6	2	80	A1
36	A B	0.060	13.1	8.0	5.25	8.375	2.6 2.6	2.6	2.0 2.0	6.6	2	80	A1
37	A B	0.073	12.8	9.5	5.25	8.375	2.5 2.5	2.5	2.4 2.3	6.5	2	30	A1
38	A B	0.073	15.3	9.3	5.25	8.375	3.5 3.5	3.5	2.1 2.5	7.0	2	30	A1
39	A B	0.073	13.1	10.1	9.25	8.375	2.5 2.5	2.5	2.8 2.4	6.9	2	80	A1
40	A B	0.060	12.9	8.0	5.25	8.375	2.5 2.5	2.5	2.8 2.3	6.6	2	80	A1
41	A B	0.073	12.9	8.8	5.25	8.375	2.5 2.8	2.6	2.8 2.8	6.4	2	30	A1
42	A B	0.073	15.1	9.0	5.25	8.375	3.6 3.5	3.6	3.0 2.0	6.8	2	30	A1
43	A B	0.073	12.9	10.0	5.25	8.375	2.5 2.5	2.5	2.0 2.0	6.6	2	80	A1
44	A B	0.060	13.0	8.5	5.25	8.375	2.5 2.6	2.6	2.0 2.5	6.6	2	80	A1
45	A B	0.077	11.0	13.4	5.25	8.375	1.6 1.5	1.6	1.9 1.9	6.6	2	80	A4
46	B	0.08	12.0	11.0	5.25	8.375	1.6	1.6	2.4	6.6	2	80	A1
47	A B	0.077	12.9	11.3	5.25	8.375	2.5 2.5	2.5	2.1 2.0	6.6	2	80	A4
48	A B	0.077	13.1	13.6	5.25	8.375	2.5 2.8	2.6	2.5 2.1	6.6	2	80	A4
49	A B	0.073	12.9	10.0	5.38	8.375	2.5 2.5	2.5	2.0 2.5	6.6	2	80	A1
50	A B	0.060	13.1	8.5	5.25	8.375	2.6 2.6	2.6	2.5 2.8	6.6	2	80	A1
51	A B	0.073	13.0	8.0	5.25	8.375	2.8 2.9	2.8	2.0 2.0	6.1	2	80	A1
52	A B	0.073	12.9	10.0	5.25	8.375	2.6 2.5	2.6	1.8 1.5	6.5	2	80	A5

^o Longitudinal column configurations shown in Appendix A, Figures A1 – A16

Table A.1 Cont. Comprehensive test results and data for No. 5 specimens with two hooks

	Hook	T_{max} lb	T_{ind} lb	T_{total} lb	T lb	$f_{su,max}$ psi	f_{su} psi	$f_{su,avg}$ psi	Joint shear at failure/ $\sqrt{f_{cm}}$	Slip at Failure in.	Failure Type
27	A	26722	26722	54217	27108	86199	87446	78954	3.3	0.194	F/S
	B	35215	27495			113596				.146(.016)	S/F
28	A	34057	30094	61508	30754	109860	99206	79634	3.2	0.251	S/F
	B	31441	31414			101422				.237(.021)	F/S
29	A	32860	32628	66273	33136	106001	106892	65062	4.7	-	F
	B	37440	33645			120776				-	S/F
30	A	20038	19968	39830	19915	64639	64242	44607	3.5	-	S
	B	29285	19863			94469				-	S/F
31	A	26203	26172	53146	26573	84524	85719	64347	3.9	-	F
	B	27858	26974			89865				-	S
32	A	29328	29328	54758	27379	94606	88319	64750	3.7	-	F/S
	B	25430	25430			82032				-	F/S
33	A	41369	28996	60169	30084	133448	97046	63996	3.7	-	F/S
	B	31173	31173			100558				-	F/S
34	A	28967	25617	51811	25905	93441	83565	68475	2.9	0.239	F/S
	B	26270	26194			84741				0.158	F/S
35	A	36570	36332	72896	36448	117967	117575	67769	5.1	-	S
	B	39949	36565			128867				-	S/F
36	A	29091	23661	47832	23916	93843	77148	52222	4.2	-	S/F
	B	24285	24171			78338				-	F/S
37	A	34198	34198	65819	32909	110316	106159	79216	3.9	0.373	F/S
	B	35367	31621			114087				.261(.035)	F/S
38	A	35824	35733	60999	30500	115563	98386	76007	3.1	0.205	F
	B	28925	25266			93305				0.238	F
39	A	35739	27537	55074	27537	115288	88829	62980	4.0	-	F/S
	B	27537	27537			88829				-	S
40	A	21633	21535	42914	21457	69782	69217	48118	3.8	-	S
	B	26769	21379			86352				-	S
41	A	23854	23854	48585	24292	76947	78363	65783	3.1	0.25	F
	B	27932	24731			90103				0.22	F/S
42	A	25266	25261	50482	25241	81504	81423	71214	2.7	-	F/S
	B	25221	25221			81359				-	F/S
43	A	43142	38421	76842	38421	139167	123938	66624	5.7	-	F/S
	B	38421	38421			123938				-	F
44	A	25321	23275	45954	22977	81681	74119	53785	3.9	-	F/S
	B	22912	22679			73909				-	F
45	A	48319	43085	86101	43051	155868	138873	87853	6.1	-	F/S
	B	43017	43017			138764				-	F/S
46	B	20282	20282	20282	20282	65426	65426	67231	1.6	-	F/S
47	A	35466	35466	79396	39698	114406	128058	69807	5.8	-	F/S
	B	43930	43930			141710				-	F
48	A	43621	42165	84648	42324	140714	136530	86440	4.9	-	F
	B	42484	42484			137044				-	F/S
49	A	37932	37807	74307	37154	122360	119850	67802	5.3	-	S/F
	B	38949	36500			125642				-	S/F
50	A	31846	29697	58888	29444	102730	94980	51134	4.8	-	F/S
	B	29191	29191			94164				-	F/S
51	A	33454	30402	61277	30638	107916	98833	63517	4.4	-	F/S
	B	30874	30874			99595				-	F/S
52	A	39822	39791	80336	40168	128457	129574	87619	4.8	-	F/S
	B	40545	40545			130789				-	F/S

Table A.1 Cont. Comprehensive test results and data for No. 5 specimens with two hooks

	Hook	f_{yt} ksi	d_{tr} in.	$A_{tr,l}$ in. ²	N_{tr}	s_{tr} in.	A_{cti} in. ²	N_{cti}	s_{cti} in.	d_s in.	s_s in.	d_{cto} in.	N_{cto}	A_s in. ²	f_{ys} ksi
27	A B	60	-	-	-	-	0.22	2	4.0	0.500	3.00	-	-	1.27	60
28	A B	60	-	-	-	-	0.22	2	4.0	0.500	3.00	-	-	1.27	60
29	A B	60	0.38	0.11	1	5.00	0.44	4	6.0	0.375	4.00	-	-	1.27	60
30	A B	60	0.38	0.11	1	5.00	0.44	4	6.0	0.375	4.00	-	-	1.27	60
31	A B	60	0.38	0.11	1	5.00	0.80	4	6.0	0.500	4.00	-	-	1.27	60
32	A B	60	0.38	0.11	1	6.00	0.66	6	3.0	0.500	3.00	-	-	1.27	60
33	A B	60	0.38	0.11	1	5.00	0.80	4	6.0	0.500	4.00	-	-	1.27	60
34	A B	60	0.38	0.11	1	6.00	0.66	6	3.0	0.500	3.00	-	-	1.27	60
35	A B	60	0.38	0.11	1	4.00	-	-	-	0.375	4.00	-	-	1.27	60
36	A B	60	0.38	0.11	1	4.00	-	-	-	0.375	4.00	-	-	1.27	60
37	A B	60	0.38	0.11	1	3.00	-	-	-	0.375	3.00	-	-	1.27	60
38	A B	60	0.38	0.11	1	3.00	-	-	-	0.375	3.00	-	-	1.27	60
39	A B	60	0.5	0.20	1	5.00	0.44	4	6.0	0.375	4.00	-	-	1.27	60
40	A B	60	0.5	0.20	1	5.00	0.44	4	6.0	0.375	4.00	-	-	1.27	60
41	A B	60	0.5	0.20	1	6.00	0.44	4	6.0	0.500	3.00	-	-	1.27	60
42	A B	60	0.5	0.20	1	6.00	0.44	4	6.0	0.500	3.00	-	-	1.27	60
43	A B	60	0.5	0.20	1	4.00	-	-	-	0.375	4.00	-	-	1.27	60
44	A B	60	0.5	0.20	1	4.00	-	-	-	0.375	4.00	-	-	1.27	60
45	A B	60	0.38	0.11	2	2.00	-	-	-	0.375	4.00	-	-	1.89	60
46	B	60	0.375	0.11	2	2.0	-	-	-	0.375	4.0	-	-	1.27	60
47	A B	60	0.38	0.11	2	2.00	-	-	-	0.375	4.00	-	-	1.89	60
48	A B	60	0.38	0.11	2	2.00	-	-	-	0.375	4.50	-	-	1.89	60
49	A B	60	0.38	0.11	2	4.00	-	-	-	0.375	4.00	-	-	1.27	60
50	A B	60	0.38	0.11	2	4.00	-	-	-	0.375	4.00	-	-	1.27	60
51	A B	60	0.38	0.11	2	4.00	-	-	-	0.500	4.00	-	-	1.27	60
52	A B	60	0.38	0.11	2	4.00	-	-	-	0.500	4.00	-	-	1.67	60

Table A.1 Cont. Comprehensive test results and data for No. 5 specimens with two hooks

	Specimen	Hook	Bend Angle	Trans. Reinf. Orient.	Hook Bar Type	l_{eh} in.	$l_{eh,avg}$ in.	f'_c psi	Age days	d_b in.
53	5-12-90-2#3-i-2.5-2-5	A B	90°	Para	A1035	5.8 5.8	5.8	11090	83	0.625
54	5-15-90-2#3-i-2.5-2-6	A B	90°	Para	A1035	6.3 6.5	6.4	15800	61	0.625
55	5-15-90-2#3-i-2.5-2-4	A B	90°	Para	A1035	3.5 4.0	3.8	15800	61	0.625
56	5-5-90-2#3-i-3.5-2-6	A B	90°	Para	A1035	6.0 5.8	5.9	5230	6	0.625
57	5-5-90-2#3-i-3.5-2-8	A B	90°	Para	A1035	7.9 7.5	7.7	5190	7	0.625
58	5-8-90-2#3-i-3.5-2-6	A B	90°	Para	A1035	6.5 6.0	6.3	8580	15	0.625
59	5-8-90-2#3-i-3.5-2-8	A B	90°	Para	A1035	7.1 7.0	7.1	8710	16	0.625
60	5-12-90-2#3-i-3.5-2-5	A B	90°	Para	A1035	5.6 5.3	5.4	10410	15	0.625
61	5-12-90-2#3-i-3.5-2-10	A B	90°	Para	A1035	10.8 10.6	10.7	11090	83	0.625
62	5-5-180-2#3-i-2.5-2-8	A B	180°	Para	A1035	8.0 8.0	8.0	5670	7	0.625
63	5-5-180-2#3-i-2.5-2-6	A B	180°	Para	A615	5.8 5.5	5.6	5860	8	0.625
64	5-8-180-2#3-i-2.5-2-7	A B	180°	Para	A1035	7.0 7.3	7.1	9080	11	0.625
65	5-8-180-2#3-i-3.5-2-7	A B	180°	Para	A1035	6.8 6.9	6.8	9080	11	0.625
66	5-8-90-4#3-i-2.5-2-8	A B	90°	Para	A1035	7.9 7.5	7.7	8380	13	0.625
67	5-8-90-4#3-i-3.5-2-8	A B	90°	Para	A1035	8.6 8.3	8.4	8380	13	0.625
68	5-5-90-5#3-o-1.5-2-5	B	90°	Para	A615	5.0	5.0	5205	5	0.625
69	5-5-90-5#3-o-1.5-2-8	A B	90°	Para	A1035	8.0 7.8	7.9	5650	6	0.625
70	5-5-90-5#3-o-1.5-2-6.5	A B	90°	Para	A1035	6.5 6.5	6.5	5780	7	0.625
71	5-5-90-5#3-o-2.5-2-5	A B	90°	Para	A615	5.2 5.1	5.2	4903	4	0.625
72	5-5-90-5#3-o-2.5-2-8	A	90°	Para	A1035	7.5	7.5	5650	6	0.625
73	5-5-90-5#3-i-2.5-2-7	A B	90°	Para	A1035	5.6 7.0	6.3	5230	6	0.625
74	5-12-90-5#3-i-2.5-2-5	A B	90°	Para	A1035	5.1 5.8	5.4	10410	15	0.625
75	5-15-90-5#3-i-2.5-2-4	A B	90°	Para	A1035	3.8 4.1	4.0	15800	62	0.625
76	5-15-90-5#3-i-2.5-2-5	A B	90°	Para	A1035	5.0 5.1	5.1	15800	62	0.625
77	5-5-90-5#3-i-3.5-2-7	A B	90°	Para	A1035	7.5 6.8	7.1	5190	7	0.625
78	5-12-90-5#3-i-3.5-2-5	A B	90°	Para	A1035	5.3 4.8	5.0	11090	83	0.625
79	5-12-90-5#3-i-3.5-2-10	A B	90°	Para	A1035	11.0 11.3	11.1	11090	83	0.625

Table A.1 Cont. Comprehensive test results and data for No. 5 specimens with two hooks

	Hook	R_r	b in.	h in.	h_{cl} in.	h_c in.	c_{so} in.	$c_{so,avg}$ in.	c_{th} in.	c_h in.	N_h	Axial Load kips	Long. Reinf. Layout ^o
53	A B	0.073	13.0	8.8	5.25	8.375	2.5 2.8	2.6	3.0 3.0	6.5	2	30	A1
54	A B	0.073	12.6	8.2	5.25	8.375	2.4 2.4	2.4	1.9 1.7	6.6	2	30	A2
55	A B	0.073	13.0	6.1	5.25	8.375	2.5 2.5	2.5	2.6 2.1	6.8	2	30	A9
56	A B	0.073	14.5	8.3	5.25	8.375	3.4 3.4	3.4	2.3 2.5	6.5	2	30	A1
57	A B	0.073	14.9	10.3	5.25	8.375	3.4 3.5	3.4	2.3 2.8	6.8	2	30	A1
58	A B	0.073	14.9	8.0	5.25	8.375	3.5 3.8	3.6	1.5 2.0	6.4	2	80	A1
59	A B	0.060	14.9	10.0	5.25	8.375	3.5 3.5	3.5	2.9 3.0	6.6	2	80	A5
60	A B	0.073	15.1	7.4	5.25	8.375	3.8 3.5	3.6	1.8 2.2	6.6	2	30	A1
61	A B	0.073	15.1	13.0	5.25	8.375	3.5 3.6	3.6	2.3 2.4	6.8	2	30	A4
62	A B	0.073	13.1	10.0	5.25	8.375	2.5 2.5	2.5	2.0 2.0	6.9	2	80	A1
63	A B	0.060	13.1	7.8	5.25	8.375	2.6 2.6	2.6	2.0 2.3	6.6	2	80	A1
64	A B	0.073	12.6	9.3	5.25	8.375	2.5 2.5	2.5	2.3 2.1	6.4	2	30	A1
65	A B	0.073	15.1	9.2	5.25	8.375	3.4 3.5	3.4	2.4 2.3	7.0	2	30	A1
66	A B	0.060	12.6	10.0	5.25	8.375	2.5 2.5	2.5	2.1 2.5	6.4	2	80	A5
67	A B	0.060	15.1	10.0	5.25	8.375	3.5 3.5	3.5	1.4 1.8	6.9	2	80	A5
68	B	0.077	10.8	7.1	5.25	8.375	1.5	1.5	2.0	6.5	2	80	A1
69	A B	0.077	10.7	10.3	5.25	8.375	1.6 1.5	1.5	2.3 2.6	6.4	2	80	A1
70	A B	0.073	10.9	8.5	5.25	8.375	1.6 1.6	1.6	2.0 2.0	6.5	2	80	A4
71	A B	0.077	13.1	7.0	5.38	8.375	2.6 2.6	2.6	1.9 1.9	6.6	2	80	A1
72	A	0.077	13.1	10.4	5.25	8.375	2.6	2.6	2.1	6.5	2	80	A1
73	A B	0.073	13.3	9.3	5.25	8.375	2.8 2.8	2.8	3.6 2.3	6.5	2	30	A1
74	A B	0.073	13.0	7.3	5.25	8.375	2.6 2.6	2.6	2.1 1.5	6.5	2	30	A1
75	A B	0.073	12.8	6.0	5.25	8.375	2.4 2.5	2.4	2.2 1.9	6.6	2	30	A9
76	A B	0.073	12.8	7.1	5.25	8.375	2.4 2.3	2.4	2.1 1.9	6.8	2	30	A2
77	A B	0.073	15.1	9.5	5.25	8.375	3.4 3.5	3.4	2.0 2.8	7.0	2	30	A1
78	A B	0.073	14.4	7.0	5.25	8.375	3.3 3.3	3.3	2.5 1.5	6.6	2	30	A1
79	A B	0.073	15.1	13.0	5.25	8.375	3.5 3.5	3.5	2.0 1.8	6.9	2	30	A4

^o Longitudinal column configurations shown in Appendix A, Figures A1 – A16

Table A.1 Cont. Comprehensive test results and data for No. 5 specimens with two hooks

	Hook	T_{max} lb	T_{ind} lb	T_{total} lb	T lb	$f_{su,max}$ psi	f_{su} psi	$f_{su,avg}$ psi	Joint shear at failure/ $\sqrt{f_{cm}}$	Slip at Failure in.	Failure Type
53	A	25201	25120	48696	24348	81295	78542	69203	2.8	-	F/S
	B	29393	23576			94816				-	F
54	A	42381	42381	85276	42638	136714	137542	91580	4.6	-	F
	B	42895	42895			138371				-	F
55	A	18652	18652	37334	18667	60167	60217	53871	2.6	-	F
	B	21256	18683			68569				-	F
56	A	21341	21146	42186	21093	68842	68042	48557	3.4	0.183	S/F
	B	21262	21040			68586				-	S/F
57	A	43675	43675	89329	44665	140887	144079	63551	5.7	-	F
	B	45654	45654			147271				-	F
58	A	29930	29930	60069	30035	96549	96886	66163	3.8	-	F
	B	30139	30139			97223				-	F/S
59	A	38022	28716	57312	28656	122652	92439	75329	2.9	-	F
	B	28596	28596			92246				-	F
60	A	27860	27860	56728	28364	89871	91497	63404	3.4	-	F
	B	28869	28869			93124				0.349	F
61	A	46561	44490	90490	45245	150197	145952	128628	3.1	-	BY
	B	46006	46001			148406				-	BY
62	A	34036	33674	68157	34078	109795	109930	68845	4.8	-	F/S
	B	34483	34483			111236				-	F/S
63	A	26852	26782	53456	26728	86620	86220	49211	4.8	-	F/S
	B	26912	26674			86814				-	F
64	A	34580	29762	58459	29230	111548	94289	77592	3.6	-	F/S
	B	28697	28697			92572				.369(.081)	F/S
65	A	29310	29285	61862	30931	94550	99777	74189	3.3	-	F/S
	B	32577	32577			105086				.329(.028)	F
66	A	33367	25867	52823	26411	107636	85198	80426	3.2	-	F/S
	B	27016	26955			87150				-	F/S
67	A	42471	37810	76960	38480	137003	124130	88273	3.9	-	F
	B	39278	39150			126704				-	S/F
68	B	22060	22060	22060	22060	71000	71000	51500	2.8	-	F/S
69	A	25173	25173	50221	25110	81202	81002	84562	4.2	-	F/S
	B	30446	25048			98211				-	F/S
70	A	26229	22736	43422	21711	84610	70035	70596	4.3	-	F/S
	B	20940	20686			67550				-	F/S
71	A	22279	22230	45058	22529	71868	72675	51578	4.9	-	F/S
	B	29466	22829			95050				-	F/S
72	A	28429	28429	28429	28429	91706	91706	80536	1.9	-	F
73	A	32080	32080	63393	31696	103484	102246	65216	5.0	-	F
	B	31340	31313			101095				-	F/S
74	A	33923	33923	68839	34420	109428	111031	79255	5.0	0.292	F/S
	B	34916	34916			112634				0.295	S/F
75	A	31312	31312	62637	31318	101006	101027	71266	4.5	0.603	F
	B	31325	31325			101048				0.378	F
76	A	38574	38574	78312	39156	124434	126309	90907	4.8	-	F
	B	46165	39737			148921				-	BY
77	A	44301	36844	72050	36025	142906	116210	73328	4.9	-	F
	B	35206	35206			113568				-	F
78	A	31472	31396	60882	30441	101522	98196	75221	4.0	-	F
	B	31302	29485			100973				-	F
79	A	46464	46464	92102	46051	149882	148551	167366	3.1	-	BY
	B	45703	45638			147430				-	BY

Table A.1 Cont. Comprehensive test results and data for No. 5 specimens with two hooks

	Hook	f_{yt} ksi	d_{tr} in.	$A_{tr,l}$ in. ²	N_{tr}	s_{tr} in.	A_{cti} in. ²	N_{cti}	s_{cti} in.	d_s in.	s_s in.	d_{cto} in.	N_{cto}	A_s in. ²	f_{ys} ksi
53	A B	60	0.38	0.11	2	3.30	0.33	3	3.3	0.500	3.00	-	-	1.27	60
54	A B	60	0.38	0.11	2	3.00	-	-	-	0.375	2.75	-	-	3.16	60
55	A B	60	0.38	0.11	2	3.00	-	-	-	0.375	1.75	-	-	2.51	60
56	A B	60	0.38	0.11	2	3.50	0.11	1	3.5	0.375	3.50	-	-	1.27	60
57	A B	60	0.38	0.11	2	3.50	-	-	-	0.375	4.00	-	-	1.27	60
58	A B	60	0.38	0.11	2	4.00	-	-	-	0.500	4.00	-	-	1.27	60
59	A B	60	0.38	0.11	2	4.00	-	-	-	0.500	4.00	-	-	1.67	60
60	A B	60	0.38	0.11	2	3.33	0.33	3	3.3	0.500	3.00	-	-	1.27	60
61	A B	60	0.38	0.11	2	3.30	-	-	-	0.375	5.00	-	-	1.89	60
62	A B	60	0.38	0.11	2	2.50	-	-	-	0.375	4.00	-	-	1.27	60
63	A B	60	0.38	0.11	2	2.50	-	-	-	0.375	4.00	-	-	1.27	60
64	A B	60	0.38	0.11	2	2.00	-	-	-	0.375	3.00	-	-	1.27	60
65	A B	60	0.38	0.11	2	2.00	-	-	-	0.375	3.00	-	-	1.27	60
66	A B	60	0.38	0.11	4	2.00	-	-	-	0.500	4.00	-	-	1.67	60
67	A B	60	0.38	0.11	4	2.00	-	-	-	0.500	4.00	-	-	1.67	60
68	B	60	0.375	0.11	5	2.00	-	-	-	0.375	2.50	-	-	1.27	60
69	A B	60	0.38	0.11	5	2.50	-	-	-	0.375	2.50	-	-	1.27	60
70	A B	60	0.38	0.11	5	2.50	-	-	-	0.375	2.50	-	-	1.89	60
71	A B	60	0.38	0.11	5	2.00	-	-	-	0.375	2.50	-	-	1.27	60
72	A	60	0.375	0.11	5	2.50	-	-	-	0.375	2.50	-	-	1.27	60
73	A B	60	0.38	0.11	5	1.75	-	-	-	0.500	3.50	-	-	1.27	60
74	A B	60	0.38	0.11	5	1.67	-	-	-	0.500	3.00	-	-	1.27	60
75	A B	60	0.38	0.11	5	1.75	-	-	-	0.375	1.75	-	-	2.51	60
76	A B	60	0.38	0.11	5	1.75	-	-	-	0.375	2.25	-	-	3.16	60
77	A B	60	0.38	0.11	5	1.75	-	-	-	0.500	3.50	-	-	1.27	60
78	A B	60	0.38	0.11	5	1.70	-	-	-	0.500	3.00	-	-	1.27	60
79	A B	60	0.38	0.11	5	1.70	-	-	-	0.375	5.00	-	-	1.89	60

Table A.2 Comprehensive test results and data for No. 8 specimens with two hooks

	Specimen	Hook	Bend Angle	Trans. Reinf. Orient.	Hook Bar Type	ℓ_{ch} in.	$\ell_{ch,avg}$ in.	f'_c psi	Age days	d_b in.
80	8-5-90-0-o-2.5-2-10a	A B	90°	Para	A1035 ^a	10.3 10.5	10.4	5270	7	1
81	8-5-90-0-o-2.5-2-10b	A B	90°	Para	A1035 ^a	9.3 10.3	9.8	5440	8	1
82	8-5-90-0-o-2.5-2-10c	A B	90°	Para	A1035 ^a	10.8 10.5	10.6	5650	9	1
83	8-8-90-0-o-2.5-2-8	A B	90°	Para	A1035 ^b	8.6 8.3	8.4	8740	12	1
84	8-8-90-0-o-3.5-2-8	A B	90°	Para	A1035 ^b	7.6 8.0	7.8	8810	14	1
85	8-8-90-0-o-4-2-8	A B	90°	Para	A1035 ^b	8.1 8.3	8.2	8630	11	1
86	8-5-90-0-i-2.5-2-16	A B	90°	Para	A1035 ^b	16.0 16.8	16.4	4980	7	1
87	8-5-90-0-i-2.5-2-9.5	A B	90°	Para	A615	9.0 10.3	9.6	5140	8	1
88	8-5-90-0-i-2.5-2-12.5	A B	90°	Para	A615	13.3 13.3	13.3	5240	9	1
89	8-5-90-0-i-2.5-2-18	A B	90°	Para	A1035 ^b	19.5 17.9	18.7	5380	11	1
90	8-5-90-0-i-2.5-2-13	A B	90°	Para	A1035 ^b	13.3 13.5	13.4	5560	11	1
91	8-5-90-0-i-2.5-2-15(1)	A B	90°	Para	A1035 ^b	14.5 15.3	14.9	5910	14	1
92	8-5-90-0-i-2.5-2-15	A B	90°	Para	A1035 ^b	15.3 14.4	14.8	6210	8	1
93	(2@3) 8-5-90-0-i-2.5-2-10 [‡]	A B	90°	Para	A615	10.4 10.6	10.5	4490	10	1
94	(2@5) 8-5-90-0-i-2.5-2-10 [‡]	A B	90°	Para	A615	10.1 10.1	10.1	4490	10	1
95	8-8-90-0-i-2.5-2-8	A B	90°	Para	A1035 ^b	8.9 8.0	8.4	7910	15	1
96	8-8-90-0-i-2.5-2-10	A B	90°	Para	A1035 ^b	9.8 9.5	9.6	7700	14	1
97	8-8-90-0-i-2.5-2-8(1)	A B	90°	Para	A1035 ^b	8.0 8.0	8.0	8780	13	1
98	8-8-90-0-i-2.5sc-2tc-9 [‡]	A B	90°	Para	A615	9.5 9.5	9.5	7710	25	1
99	8-8-90-0-i-2.5sc-9tc-9	A B	90°	Para	A615	9.3 9.0	9.1	7710	25	1
100	(2@3) 8-8-90-0-i-2.5-9-9	A B	90°	Para	A615	9.3 9.0	9.1	7510	21	1
101	(2@4) 8-8-90-0-i-2.5-9-9	A B	90°	Para	A615	9.9 10.0	9.9	7510	21	1
102	8-12-90-0-i-2.5-2-9	A B	90°	Para	A1035 ^b	9.0 9.0	9.0	11160	77	1
103	8-12-90-0-i-2.5-2-12.5	A B	90°	Para	A1035 ^c	12.9 12.8	12.8	11850	39	1
104	8-12-90-0-i-2.5-2-12	A B	90°	Para	A1035 ^c	12.1 12.1	12.1	11760	34	1
105	8-15-90-0-i-2.5-2-8.5	A B	90°	Para	A1035 ^c	8.8 8.9	8.8	15800	61	1

[‡] Specimen contained A1035 Grade 120 for column longitudinal steel

^a Heat 1, ^b Heat 2, ^c Heat 3 as described in Table 2.3

Table A.2 Cont. Comprehensive test results and data for No. 8 specimens with two hooks

	Hook	R_r	b in.	h in.	h_{cl} in.	h_c in.	c_{so} in.	$c_{so,avg}$ in.	c_{th} in.	c_h in.	N_h	Axial Load kips	Long. Reinf. Layout ^o
80	A B	0.084	17.1	12.3	10.5	8.375	2.5 2.6	2.6	2.0 1.8	10.0	2	80	A2
81	A B	0.084	17.0	12.5	10.5	8.375	2.5 2.5	2.5	3.3 2.3	10.0	2	80	A2
82	A B	0.084	17.0	12.3	10.5	8.375	2.5 2.5	2.5	1.5 1.8	10.0	2	80	A2
83	A B	0.078	16.3	10.4	10.5	8.375	2.8 2.5	2.6	1.8 2.1	9.0	2	30	A2
84	A B	0.078	18.9	10.0	10.5	8.375	3.5 3.6	3.6	2.4 2.0	9.8	2	30	A2
85	A B	0.078	20.0	10.6	10.5	8.375	4.5 3.8	4.1	2.5 2.4	9.8	2	30	A2
86	A B	0.078	17.0	17.9	10.5	8.375	2.8 2.8	2.8	1.8 1.4	9.5	2	80	A2
87	A B	0.078	16.8	12.0	10.5	8.375	2.8 2.5	2.6	3.0 1.8	9.5	2	80	A2
88	A B	0.078	17.3	14.5	10.5	8.375	2.8 2.8	2.8	1.3 1.3	9.8	2	80	A2
89	A B	0.078	17.5	20.3	10.5	8.375	2.5 2.5	2.5	0.8 2.4	10.5	2	30	A6
90	A B	0.078	16.8	15.3	10.5	8.375	2.5 2.5	2.5	2.0 1.8	9.8	2	30	A2
91	A B	0.073	16.7	17.3	10.5	8.375	2.5 2.6	2.5	2.8 2.0	9.6	2	30	A2
92	A B	0.073	16.6	17.3	10.5	8.375	2.5 2.6	2.6	2.0 2.9	9.5	2	30	A2
93	A B	0.073	9.0	12.0	10.5	8.375	2.5 2.5	2.5	1.6 1.4	2.0	2	30	A2
94	A B	0.073	10.9	12.0	10.5	8.375	2.5 2.3	2.4	1.9 1.9	4.1	2	30	A2
95	A B	0.078	16.3	10.0	10.5	8.375	2.8 2.9	2.8	1.1 2.0	8.6	2	30	A2
96	A B	0.078	16.6	12.0	10.5	8.375	2.8 2.9	2.8	2.3 2.5	9.0	2	30	A2
97	A B	0.078	17.0	10.8	10.5	8.375	2.8 2.8	2.8	2.8 2.8	9.5	2	30	A2
98	A B	0.073	17.3	11.0	10.5	8.375	2.5 2.8	2.6	1.5 1.5	10.0	2	30	A2
99	A B	0.073	17.5	18.0	10.5	8.375	2.8 2.8	2.8	8.8 9.0	10.0	2	30	A7
100	A B	0.073	9.1	18.0	10.5	8.375	2.5 2.6	2.6	8.8 9.0	2.0	2	30	A7
101	A B	0.073	10.2	18.0	10.5	8.375	2.6 2.5	2.5	8.1 8.0	3.1	2	30	A7
102	A B	0.078	17.0	11.4	10.5	8.375	2.8 2.6	2.7	2.4 2.4	9.6	2	30	A2
103	A B	0.073	17.4	14.6	10.5	8.375	2.6 2.6	2.6	1.7 1.8	10.1	2	30	A2
104	A B	0.073	16.8	14.0	10.5	8.375	2.5 2.4	2.5	1.9 1.9	9.8	2	30	A2
105	A B	0.073	17.0	10.8	10.5	8.375	2.5 2.5	2.5	2.0 1.9	10.0	2	30	A6

^o Longitudinal column configurations shown in Appendix A, Figures A1 – A16

Table A.2 Cont. Comprehensive test results and data for No. 8 specimens with two hooks

	Hook	T_{max} lb	T_{ind} lb	T_{total} lb	T lb	$f_{su,max}$ psi	f_{su} psi	$f_{s,ACI}$ psi	Joint shear at failure/ $\sqrt{f_{cm}}$	Slip at Failure in.	Failure Type
80	A	40645	38970	84628	42314	51449	53562	53798	3.4	-	F/S
	B	46612	45658			59003				0.186	S/F
81	A	47870	38190	67302	33651	60596	42596	51366	2.6	-	F/S
	B	30599	29112			38733				-	S/F
82	A	62682	57437	111949	55975	79345	70854	57046	4.3	-	F/S
	B	54558	54512			69061				0.132	S/F/TK
83	A	44396	32792	66029	33015	56198	41791	56343	2.5	0.153	S/TK
	B	33238	33238			42073				0.113	S/TK
84	A	35613	35613	71745	35872	45080	45408	52378	2.5	-	F/S
	B	44488	36132			56314				-	S/F
85	A	37130	35849	75022	37511	47000	47482	54329	2.3	0.362	S/F
	B	39173	39173			49586				(.0.017)	S
86	A	83310	83310	166479	83239	105455	105366	82541	4.7	-	F/S
	B	86063	83169			108940				-	F/TK
87	A	44627	44627	88971	44485	56489	56311	49289	3.7	-	F
	B	65800	44344			83291				-	S
88	A	65254	65254	131639	65819	82600	83316	68510	4.4	-	S/F
	B	69872	66385			88446				-	S
89	A	100169	82023	161763	80881	126796	102381	97907	3.8	-	F/S/TK
	B	79805	79740			101018				0.153	F/S/TK
90	A	73143	65881	131078	65539	92586	82960	71237	4.2	-	S
	B	65197	65197			82527				-	F/S
91	A	64532	64532	127534	63767	81686	80718	81681	3.5	-	F/S
	B	87275	63002			110475				-	S
92	A	76256	76162	150955	75478	96527	95541	83377	4.0	-	S/F
	B	80724	74793			102182				-	S/F
93	A	38900	38908	80626	40313	49241	51029	50256	6.8	0.2	F
	B	41700	41718			52785				-	F
94	A	41853	41853	80104	40052	52979	50699	48150	5.5	0.33	F
	B	38251	38251			48419				0	F/S
95	A	54674	45317	90486	45243	69208	57269	53601	3.8	-	F/TK
	B	45169	45169			57176				-	F/S
96	A	50000	49985	102911	51455	63291	65134	60328	3.6	0.195	F
	B	52926	52926			66995				0.185	F
97	A	38047	35988	73642	36821	48161	46609	53544	2.6	0.387	F/S
	B	37660	37654			47671				0.229	F/S
98	A	35543	35543	70199	35100	44991	44430	59583	2.6	0.104	F
	B	34656	34656			43868				0	F
99	A	38519	38519	75358	37679	48758	47695	57231	1.7	0.12	F
	B	36839	36839			46632				0.29	F
100	A	34015	33826	61345	30672	43057	38826	56484	2.6	-	F
	B	27575	27518			34905				-	F
101	A	32856	32856	68391	34195	41590	43285	61513	2.6	0.018	F
	B	35534	35534			44980				0	F
102	A	50809	50677	99845	49923	64315	63193	67912	3.0	0.219	F/S
	B	54796	49168			69362				-	S/F
103	A	66009	65995	133873	66937	83555	84730	99624	2.9	0.295	F/S
	B	77378	67878			97947				0.266	F/S
104	A	70689	65980	131758	65879	89479	83391	93920	3.1	-	S/F
	B	65778	65778			83263				0.0119	F/S
105	A	43063	43063	87150	43575	54510	55158	79122	2.3	-	F
	B	44087	44087			55807				-	F

Table A.2 Cont. Comprehensive test results and data for No. 8 specimens with two hooks

	Hook	f_{yt} ksi	d_{tr} in.	$A_{tr,l}$ in. ²	N_{tr}	S_{tr} in.	A_{cti} in. ²	N_{cti}	S_{cti} in.	d_s in.	S_s in.	d_{cto} in.	N_{cto}	A_s in. ²	f_{ys} ksi
80	A B	60	-	-	-	-	3.10	5	3.5	0.63	3.50	-	-	3.16	60
81	A B	60	-	-	-	-	3.10	5	3.5	0.63	3.50	-	-	3.16	60
82	A B	60	-	-	-	-	3.10	5	3.5	0.63	3.50	-	-	3.16	60
83	A B	60	-	-	-	-	2.00	10	3.0	0.50	1.75	-	-	3.16	60
84	A B	60	-	-	-	-	2.00	10	3.0	0.50	1.75	-	-	3.16	60
85	A B	60	-	-	-	-	2.00	10	3.0	0.50	1.75	-	-	3.16	60
86	A B	60	-	-	-	-	2.00	10	3.0	0.50	3.00	-	-	3.16	60
87	A B	60	-	-	-	-	2.00	10	3.0	0.50	3.00	-	-	3.16	60
88	A B	60	-	-	-	-	2.00	10	3.0	0.50	3.00	-	-	3.16	60
89	A B	60	-	-	-	-	1.10	10	3.0	0.38	3.50	0.375	1	3.78	60
90	A B	60	-	-	-	-	1.00	5	3.0	0.50	3.00	0.375	1	3.16	60
91	A B	60	-	-	-	-	1.10	10	3.0	0.38	3.50	0.375	2	3.16	60
92	A B	60	-	-	-	-	1.10	10	3.0	0.38	3.50	0.375	2	3.16	60
93	A B	60	-	-	-	-	-	-	-	0.38	5.00	-	-	3.16	120
94	A B	60	-	-	-	-	-	-	-	0.38	5.00	-	-	3.16	120
95	A B	60	-	-	-	-	1.60	8	4.0	0.50	1.75	-	-	3.16	60
96	A B	60	-	-	-	-	1.60	8	4.0	0.63	3.50	-	-	3.16	60
97	A B	60	-	-	-	-	1.60	8	4.0	0.50	1.50	-	-	3.16	60
98	A B	60	-	-	-	-	-	-	-	0.38	4.00	-	-	3.16	60
99	A B	60	-	-	-	-	-	-	-	0.38	4.00	-	-	4.74	60
100	A B	60	-	-	-	-	-	-	-	0.38	4.00	-	-	4.74	60
101	A B	60	-	-	-	-	-	-	-	0.38	4.00	-	-	4.74	60
102	A B	60	-	-	-	-	0.88	8	4.0	0.50	4.00	0.375	2	3.16	60
103	A B	60	-	-	-	-	-	-	-	0.50	2.25	-	-	3.16	60
104	A B	60	-	-	-	-	-	-	-	0.38	4.00	-	-	3.16	60
105	A B	60	-	-	-	-	-	-	-	0.38	4.00	-	-	3.78	60

Table A.2 Cont. Comprehensive test results and data for No. 8 specimens with two hooks

	Specimen	Hook	Bend Angle	Trans. Reinf. Orient.	Hook Bar Type	l_{eh} in.	$l_{eh,avg}$ in.	f'_c psi	Age days	d_b in.
106	8-15-90-0-i-2.5-2-13	A B	90°	Para	A1035 ^c	12.8 12.8	12.8	15800	61	1
107	8-5-90-0-i-3.5-2-18	A B	90°	Para	A1035 ^b	19.0 18.0	18.5	5380	11	1
108	8-5-90-0-i-3.5-2-13	A B	90°	Para	A1035 ^b	13.4 13.4	13.4	5560	11	1
109	8-5-90-0-i-3.5-2-15(2)	A B	90°	Para	A1035 ^c	15.6 14.9	15.3	5180	8	1
110	8-5-90-0-i-3.5-2-15(1)	A B	90°	Para	A1035 ^c	15.4 15.1	15.3	6440	9	1
111	8-8-90-0-i-3.5-2-8(1)	A B	90°	Para	A1035 ^b	7.8 7.8	7.8	7910	15	1
112	8-8-90-0-i-3.5-2-10	A B	90°	Para	A1035 ^b	8.8 10.8	9.8	7700	14	1
113	8-8-90-0-i-3.5-2-8(2)	A B	90°	Para	A1035 ^b	8.5 8.0	8.3	8780	13	1
114	8-12-90-0-i-3.5-2-9	A B	90°	Para	A1035 ^b	9.0 9.0	9.0	11160	77	1
115	8-8-90-0-i-4-2-8	A B	90°	Para	A1035 ^b	7.6 8.0	7.8	8740	12	1
116	8-5-180-0-i-2.5-2-11	A B	180°	Para	A615	11.0 11.0	11.0	4550	7	1
117	8-5-180-0-i-2.5-2-14	A B	180°	Para	A1035 ^b	14.0 14.0	14.0	4840	8	1
118	(2@3) 8-5-180-0-i-2.5-2-10 [‡]	A B	180°	Para	A615	10.3 10.0	10.2	5260	15	1
119	(2@5)8-5-180-0-i-2.5-2-10 [‡]	A B	180°	Para	A615	10.0 10.0	10.0	5260	15	1
120	8-8-180-0-i-2.5-2-11.5	A B	180°	Para	A1035 ^b	9.3 9.3	9.3	8630	11	1
121	8-12-180-0-i-2.5-2-12.5	A B	180°	Para	A1035 ^c	12.8 12.5	12.6	11850	39	1
122	8-5-180-0-i-3.5-2-11	A B	180°	Para	A615	11.6 11.6	11.6	4550	7	1
123	8-5-180-0-i-3.5-2-14	A B	180°	Para	A1035 ^b	14.4 13.9	14.1	4840	8	1
124	8-15-180-0-i-2.5-2-13.5	A B	180°	Para	A1035 ^c	13.8 13.5	13.6	16510	88	1
125	8-5-90-1#3-i-2.5-2-16	A B	90°	Para	A1035 ^b	15.6 15.6	15.6	4810	6	1
126	8-5-90-1#3-i-2.5-2-12.5	A B	90°	Para	A1035 ^b	12.5 12.5	12.5	5140	8	1
127	8-5-90-1#3-i-2.5-2-9.5	A B	90°	Para	A615	9.0 9.0	9.0	5240	9	1
128	8-5-180-1#3-i-2.5-2-11	A B	180°	Para	A615	11.5 11.5	11.5	4300	6	1
129	8-5-180-1#3-i-2.5-2-14	A B	180°	Para	A1035 ^b	14.8 15.0	14.9	4870	9	1
130	8-5-180-1#3-i-3.5-2-11	A B	180°	Para	A615	11.6 10.6	11.1	4550	7	1
131	8-5-180-1#3-i-3.5-2-14	A B	180°	Para	A1035 ^b	15.6 14.5	15.1	4840	8	1

[‡] Specimen contained A1035 Grade 120 for column longitudinal steel

^a Heat 1, ^b Heat 2, ^c Heat 3 as described in Table 2.3

Table A.2 Cont. Comprehensive test results and data for No. 8 specimens with two hooks

	Hook	R_r	b in.	h in.	h_{cl} in.	h_c in.	c_{so} in.	$c_{so,avg}$ in.	c_{th} in.	c_h in.	N_h	Axial Load kips	Long. Reinf. Layout ^o
106	A B	0.073	16.8	14.8	10.5	8.375	2.4 2.5	2.4	2.1 2.0	9.9	2	30	A7
107	A B	0.078	18.5	20.4	10.5	8.375	3.8 3.4	3.6	1.4 2.4	9.4	2	30	A6
108	A B	0.078	18.4	15.3	10.5	8.375	3.6 3.4	3.5	1.9 1.9	9.4	2	30	A2
109	A B	0.073	18.5	17.3	10.5	8.375	3.5 3.5	3.5	1.6 2.4	9.5	2	30	A2
110	A B	0.073	18.8	17.1	10.5	8.375	3.3 3.4	3.3	1.8 2.0	10.1	2	30	A2
111	A B	0.078	18.3	10.0	10.5	8.375	3.5 3.8	3.6	2.3 2.3	9.0	2	30	A2
112	A B	0.078	18.5	12.0	10.5	8.375	3.8 3.8	3.8	3.3 1.3	9.0	2	30	A2
113	A B	0.078	19.4	10.6	10.5	8.375	3.6 3.8	3.7	2.1 2.6	10.0	2	30	A2
114	A B	0.078	19.0	11.3	10.5	8.375	3.5 3.8	3.6	2.4 2.1	9.8	2	30	A2
115	A B	0.078	19.9	10.5	10.5	8.375	4.5 3.9	4.2	2.9 2.5	9.5	2	30	A2
116	A B	0.078	17.5	13.0	10.5	8.375	3.0 2.8	2.9	2.0 2.0	9.8	2	80	A2
117	A B	0.078	17.1	16.0	10.5	8.375	2.8 2.6	2.7	2.0 2.0	9.8	2	80	A2
118	A B	0.073	8.9	12.0	10.5	8.375	2.5 2.4	2.4	1.7 2.0	2.0	2	30	A10
119	A B	0.073	11.0	12.0	10.5	8.375	2.4 2.5	2.4	2.0 2.0	4.1	2	30	A10
120	A B	0.078	17.5	13.8	10.5	8.375	3.0 3.0	3.0	4.5 4.5	9.5	2	30	A2
121	A B	0.073	17.1	14.9	10.5	8.375	3.0 2.5	2.8	2.1 2.4	9.6	2	30	A2
122	A B	0.078	19.5	13.0	10.5	8.375	3.8 3.8	3.8	1.4 1.4	10.0	2	80	A2
123	A B	0.078	19.4	16.0	10.5	8.375	3.9 3.8	3.8	1.6 2.1	9.8	2	80	A2
124	A B	0.073	17.0	15.8	10.5	8.375	2.5 2.5	2.5	2.0 2.3	10.0	2	30	A7
125	A B	0.078	17.3	17.9	10.5	8.375	2.8 3.0	2.9	2.3 2.3	9.5	2	80	A2
126	A B	0.078	17.1	14.6	10.5	8.375	2.6 2.8	2.7	2.1 2.1	9.8	2	80	A2
127	A B	0.078	17.1	11.5	10.5	8.375	2.6 2.8	2.7	2.5 2.5	9.8	2	80	A2
128	A B	0.078	17.0	13.0	10.5	8.375	2.5 2.5	2.5	1.5 1.5	10.0	2	80	A2
129	A B	0.078	17.5	16.0	10.5	8.375	2.8 2.9	2.8	1.3 1.0	9.9	2	80	A2
130	A B	0.078	19.3	13.0	10.5	8.375	3.8 3.5	3.6	1.4 2.4	10.0	2	80	A2
131	A B	0.078	19.3	16.5	10.5	8.375	3.6 3.6	3.6	0.9 2.0	10.0	2	80	A2

^o Longitudinal column configurations shown in Appendix A, Figures A1 – A16

Table A.2 Cont. Comprehensive test results and data for No. 8 specimens with two hooks

	Hook	T_{max} lb	T_{ind} lb	T_{total} lb	T lb	$f_{su,max}$ psi	f_{su} psi	$f_{s,ACI}$ psi	Joint shear at failure/ $\sqrt{f_{cm}}$	Slip at Failure in.	Failure Type
106	A B	77232 79007	77232 79007	156239	78120	97762 100009	98885	114756	3.0	- -	F/S F
107	A B	96026 105140	96026 94717	190743	95372	121552 133089	120724	96925	4.2	0.181 -	F/S/TK F/S
108	A B	69449 68307	67892 68307	136199	68099	87910 86464	86202	71237	3.9	- -	F/S S/F
109	A B	106184 85459	89959 85459	175417	87709	134410 108176	111024	78398	4.6	- -	S S/F
110	A B	71216 79405	70412 70890	141302	70651	90146 100512	89432	87415	3.3		S/F S
111	A B	43697 43993	43697 43993	87690	43845	55313 55687	55500	49234	3.3	0.144 0.156	S/F S/F
112	A B	55230 71880	55088 56046	111134	55567	69911 90987	70338	61111	3.5	0.195 0.242	F/S S/F
113	A B	41170 42930	41170 42899	84069	42034	52114 54341	53208	55217	2.6	0.133 0.201	F F
114	A B	61380 68385	61380 59097	120477	60238	77696 86563	76251	67912	3.2	0.434	F F/S
115	A B	37554 48708	37554 37309	74863	37431	47537 61656	47381	52170	2.3	- -	F/S F
116	A B	45587 50511	45587 46699	92286	46143	57705 63938	58409	52999	3.6	0.275 -	S/F S
117	A B	49439 69415	49439 48866	98305	49152	62581 87867	62218	69570	3.1	0.088 0.096	S S
118	A B	47587 56064	47587 56064	103651	51825	60236 70967	65602	52614	8.1	0 0.9	F F
119	A B	52300 54030	52300 54030	106330	53165	66202 68392	67297	51804	6.7		F F
120	A B	62777 80190	62777 80190	142967	71484	79465 101506	90485	61379	3.9	- -	F/S F/S
121	A B	74782 92250	74782 75635	150417	75208	94661 116772	95201	98166	3.3	0.193 0.242	F/S F
122	A B	58575 60519	58145 60439	118584	59292	74145 76606	75053	56011	4.2	0.372 0.239	F/S S
123	A B	63745 78050	63689 63320	127009	63504	80690 98797	80385	70191	3.6	- -	S F/S
124	A B	90688 89145	90688 89145	179833	89916	114795 112841	113818	125050	3.2	- -	- F/S
125	A B	94588 73936	75682 73936	149617	74809	119731 93589	94694	77429	4.2	- -	F/S F/S
126	A B	73919 64783	64891 64783	129674	64837	93569 82004	82072	64012	4.4	- -	F/S S/F
127	A B	62525 65289	59716 64750	124467	62233	79145 82645	78776	46535	5.3	- -	S F/S
128	A B	57294 68950	48342 51122	99464	49732	72524 87278	62952	53865	4.2	0.088 0.341	S/F S/F
129	A B	67269 70909	67183 70860	138043	69021	85150 89758	87369	74147	4.3	- 0.123	S/F F/S
130	A B	62945 56154	54681 56100	110781	55390	79678 71082	70114	53602	4.0	0.434 0.216	S S
131	A B	78657 76919	75069 76919	151988	75994	99565 97366	96195	74850	4.2	0.232 0.227	S/F S/F

Table A.2 Cont. Comprehensive test results and data for No. 8 specimens with two hooks

	Hook	f_{yt} ksi	d_{tr} in.	$A_{tr,t}$ in. ²	N_{tr}	S_{tr} in.	A_{cti} in. ²	N_{cti}	S_{cti} in.	d_s in.	S_s in.	d_{cto} in.	N_{cto}	A_s in. ²	f_{ys} ksi
106	A B	60	-	-	-	-	-	-	-	0.38	5.00	-	-	4.74	60
107	A B	60	-	-	-	-	1.10	10	3.0	0.38	3.50	0.375	1	3.78	60
108	A B	60	-	-	-	-	1.00	5	3.0	0.50	3.00	0.375	1	3.16	60
109	A B	60	-	-	-	-	1.10	10	3.0	0.38	3.50	0.375	2	3.16	60
110	A B	60	-	-	-	-	1.10	10	3.0	0.38	3.50	0.375	2	3.16	60
111	A B	60	-	-	-	-	1.60	8	4.0	0.50	1.75	-	-	3.16	60
112	A B	60	-	-	-	-	1.60	8	4.0	0.63	3.50	-	-	3.16	60
113	A B	60	-	-	-	-	1.60	8	4.0	0.50	1.50	-	-	3.16	60
114	A B	60	-	-	-	-	0.88	8	4.0	0.50	4.00	0.375	2	3.16	60
115	A B	60	-	-	-	-	1.60	8	4.0	0.50	1.75	-	-	3.16	60
116	A B	60	-	-	-	-	0.44	4	3.5	0.50	3.50	-	-	3.16	60
117	A B	60	-	-	-	-	0.44	4	3.5	0.50	3.50	-	-	3.16	60
118	A B	60	-	-	-	-	-	-	-	0.50	4.00	-	-	6.32	120
119	A B	60	-	-	-	-	-	-	-	0.50	4.00	-	-	6.32	120
120	A B	60	-	-	-	-	0.44	4	3.0	0.50	3.00	-	-	3.16	60
121	A B	60	-	-	-	-	-	-	-	0.50	2.25	-	-	3.16	60
122	A B	60	-	-	-	-	0.44	4	3.5	0.50	3.50	-	-	3.16	60
123	A B	60	-	-	-	-	0.44	4	3.5	0.50	3.50	-	-	3.16	60
124	A B	60	-	-	-	-	-	-	-	0.50	4.00	-	-	4.74	60
125	A B	60	0.38	0.11	1	9.00	2.00	10	3.0	0.50	3.00	-	-	3.16	60
126	A B	60	0.38	0.11	1	9.00	2.00	10	3.0	0.50	3.00	-	-	3.16	60
127	A B	60	0.38	0.11	1	9.00	2.00	10	3.0	0.50	3.00	-	-	3.16	60
128	A B	60	0.38	0.11	1	3.50	0.44	4	4.5	0.50	3.50	-	-	3.16	60
129	A B	60	0.38	0.11	1	3.50	0.44	4	4.5	0.50	3.50	-	-	3.16	60
130	A B	60	0.38	0.11	1	3.50	0.44	4	4.5	0.50	3.50	-	-	3.16	60
131	A B	60	0.38	0.11	1	3.50	0.44	4	4.5	0.50	3.50	-	-	3.16	60

Table A.2 Cont. Comprehensive test results and data for No. 8 specimens with two hooks

	Specimen	Hook	Bend Angle	Trans. Reinf. Orient.	Hook Bar Type	l_{eh} in.	$l_{eh,avg}$ in.	f'_c psi	Age days	d_b in.
132	8-8-180-1#4-i-2.5-2-11.5	A B	180°	Para	A1035 ^b	12.0 12.3	12.1	8740	12	1
133	8-5-90-2#3-i-2.5-2-16	A B	90°	Para	A1035 ^b	15.0 15.8	15.4	4810	6	1
134	8-5-90-2#3-i-2.5-2-9.5	A B	90°	Para	A615	9.0 9.3	9.1	5140	8	1
135	8-5-90-2#3-i-2.5-2-12.5	A B	90°	Para	A615	12.0 12.0	12.0	5240	9	1
136	8-5-90-2#3-i-2.5-2-8.5	A B	90°	Para	A1035 ^c	8.9 9.6	9.3	5240	6	1
137	8-5-90-2#3-i-2.5-2-14	A B	90°	Para	A1035 ^c	13.5 14.0	13.8	5450	7	1
138	(2@3) 8-5-90-2#3-i-2.5-2-10 [‡]	A B	90°	Para	A615	10.0 10.5	10.3	4760	11	1
139	(2@5) 8-5-90-2#3-i-2.5-2-10 [‡]	A B	90°	Para	A615	9.6 10.0	9.8	4760	11	1
140	8-8-90-2#3-i-2.5-2-8	A B	90°	Para	A1035 ^b	8.0 8.5	8.3	7700	14	1
141	8-8-90-2#3-i-2.5-2-10	A B	90°	Para	A1035 ^b	9.9 9.5	9.7	8990	17	1
142	8-12-90-2#3-i-2.5-2-9	A B	90°	Para	A1035 ^b	9.0 9.0	9.0	11160	77	1
143	8-12-90-2#3-i-2.5-2-11	A B	90°	Para	A1035 ^c	10.5 11.3	10.9	12010	42	1
144	8-12-90-2#3vr-i-2.5-2-11	A B	90°	Perp	A1035 ^c	10.9 10.4	10.6	12010	42	1
145	8-15-90-2#3-i-2.5-2-6	A B	90°	Para	A1035 ^c	5.8 6.4	6.1	15800	61	1
146	8-15-90-2#3-i-2.5-2-11	A B	90°	Para	A1035 ^c	11.3 10.8	11.0	15800	61	1
147	8-5-90-2#3-i-3.5-2-17	A B	90°	Para	A1035 ^b	17.5 17.0	17.3	5570	12	1
148	8-5-90-2#3-i-3.5-2-13	A B	90°	Para	A1035 ^b	13.8 13.5	13.6	5560	11	1
149	8-8-90-2#3-i-3.5-2-8	A B	90°	Para	A1035 ^b	8.0 8.1	8.1	8290	16	1
150	8-8-90-2#3-i-3.5-2-10	A B	90°	Para	A1035 ^b	8.8 8.8	8.8	8990	17	1
151	8-12-90-2#3-i-3.5-2-9	A B	90°	Para	A1035 ^b	9.0 9.0	9.0	11160	77	1
152	8-5-180-2#3-i-2.5-2-11	A B	180°	Para	A615	10.8 10.5	10.6	4550	7	1
153	8-5-180-2#3-i-2.5-2-14	A B	180°	Para	A1035 ^b	13.5 14.0	13.8	4870	9	1
154	(2@3) 8-5-180-2#3-i-2.5-2-10 [‡]	A B	180°	Para	A615	10.3 10.3	10.3	5400	16	1
155	(2@5) 8-5-180-2#3-i-2.5-2-10 [‡]	A B	180°	Para	A615	10.3 9.8	10.0	5400	16	1
156	8-8-180-2#3-i-2.5-2-11.5	A B	180°	Para	A1035 ^b	10.5 10.3	10.4	8810	14	1

[‡] Specimen contained A1035 Grade 120 for column longitudinal steel

^a Heat 1, ^b Heat 2, ^c Heat 3 as described in Table 2.3

Table A.2 Cont. Comprehensive test results and data for No. 8 specimens with two hooks

	Hook	R_r	b in.	h in.	h_{cl} in.	h_c in.	c_{so} in.	$c_{so,avg}$ in.	c_{th} in.	c_h in.	N_h	Axial Load kips	Long. Reinf. Layout ^o
132	A B	0.078	17.1	14.0	10.5	8.375	2.9 2.8	2.8	2.0 1.8	9.5	2	30	A2
133	A B	0.078	17.1	17.9	10.5	8.375	2.8 2.9	2.8	2.9 2.1	9.5	2	80	A2
134	A B	0.078	17.0	11.6	10.5	8.375	2.5 2.5	2.5	2.6 2.3	10.0	2	80	A2
135	A B	0.078	17.0	14.6	10.5	8.375	2.8 2.8	2.8	2.6 2.6	9.5	2	80	A2
136	A B	0.073	17.1	10.7	10.5	8.375	3.0 3.0	3.0	1.8 1.1	9.1	2	30	A2
137	A B	0.073	17.0	16.1	10.5	8.375	2.8 3.0	2.9	2.6 2.1	9.3	2	30	A2
138	A B	0.073	9.3	12.0	10.5	8.375	2.5 2.5	2.5	2.0 1.5	2.3	2	30	A2
139	A B	0.073	10.9	12.0	10.5	8.375	2.5 2.5	2.5	2.4 2.0	3.9	2	30	A2
140	A B	0.078	16.9	10.0	10.5	8.375	3.0 2.9	2.9	2.0 1.5	9.0	2	30	A2
141	A B	0.078	16.0	12.0	10.5	8.375	2.8 2.8	2.8	2.1 2.5	8.5	2	30	A2
142	A B	0.078	17.0	11.3	10.5	8.375	2.9 2.6	2.8	2.3 2.3	9.5	2	30	A2
143	A B	0.073	17.0	12.9	10.5	8.375	2.8 2.8	2.8	2.4 1.6	9.5	2	30	A2
144	A B	0.073	16.5	13.0	10.5	8.375	2.5 2.3	2.4	2.1 2.6	9.8	2	30	A2
145	A B	0.073	16.8	8.1	10.5	8.375	2.5 2.4	2.4	2.3 1.8	9.9	2	30	A11
146	A B	0.073	17.0	13.1	10.5	8.375	2.5 2.5	2.5	1.9 2.4	10.0	2	30	A11
147	A B	0.078	18.9	19.3	10.5	8.375	3.3 3.5	3.4	1.8 2.3	10.1	2	30	A2
148	A B	0.078	19.0	15.3	10.5	8.375	3.1 3.6	3.4	1.5 1.8	10.3	2	30	A2
149	A B	0.078	17.9	10.0	10.5	8.375	3.6 3.8	3.7	2.0 1.9	8.5	2	30	A2
150	A B	0.078	17.9	12.0	10.5	8.375	3.6 3.8	3.7	3.3 3.3	8.5	2	30	A2
151	A B	0.078	19.3	11.3	10.5	8.375	3.6 4.0	3.8	2.3 2.4	9.6	2	30	A2
152	A B	0.078	16.8	13.0	10.5	8.375	2.8 2.5	2.6	2.3 2.5	9.5	2	80	A2
153	A B	0.078	17.3	16.0	10.5	8.375	2.8 2.8	2.8	2.5 2.0	9.8	2	80	A2
154	A B	0.073	9.0	12.0	10.5	8.375	2.5 2.5	2.5	1.8 1.8	2.0	2	30	A10
155	A B	0.073	11.0	12.0	10.5	8.375	2.5 2.5	2.5	1.8 2.3	4.0	2	30	A10
156	A B	0.078	17.5	12.8	10.5	8.375	2.8 2.8	2.8	2.3 2.5	10.0	2	30	A2

^o Longitudinal column configurations shown in Appendix A, Figures A1 – A16

Table A.2 Cont. Comprehensive test results and data for No. 8 specimens with two hooks

	Hook	T_{max} lb	T_{ind} lb	T_{total} lb	T lb	$f_{su,max}$ psi	f_{su} psi	$f_{s,ACI}$ psi	Joint shear at failure/ $\sqrt{f_{cm}}$	Slip at Failure in.	Failure Type
132	A B	72047 72506	71987 72475	144462	72231	91199 91780	91432	80967	3.9	- ,(0.013)	F/S F/S
133	A B	80014 92780	79629 79629	159258	79629	101284 117443	100796	76166	4.5	- -	S/F F
134	A B	54916 53621	53621 53621	107242	53621	69513 67874	67874	46729	4.6	- -	F F
135	A B	74108 76334	67801 76334	144135	72067	93808 96625	91225	62047	4.9	- -	F F/S
136	A B	52863 48439	52862 48260	101122	50561	66915 61315	64001	47828	4.6		F/S S
137	A B	76959 77540	76388 77540	153927	76964	97416 98151	97422	72506	4.6		S/F F/S
138	A B	58584 47051	58435 35184	93619	46810	74157 59558	59253	50513	7.4	0.21 -	F F
139	A B	48430 48617	48412 48617	97029	48515	61303 61541	61411	48357	6.5	0.23 0.108	F F
140	A B	46211 55377	46211 49540	95751	47876	58495 70098	60602	51710	3.9	- -	F/S F/S
141	A B	60670 67001	60670 61378	122047	61024	76797 84812	77245	65609	4.1	0.186 0.152	F F
142	A B	61813 60251	61813 60213	122026	61013	78244 76267	77232	67912	3.7	0.345 0.361	F/S S/F
143	A B	68128 79794	68101 69264	137365	68683	86237 101004	86940	85128	3.5	0.181 0.165	F F
144	A B	50709 66830	50709 54637	105346	52673	64188 84595	66674	83171	2.7	- 0.13	F/S F
145	A B	37450 37689	37450 37689	75138	37569	47405 47707	47556	54712	2.7	- -	F F
146	A B	99011 83603	83072 83567	166640	83320	125330 105827	105468	98763	3.6	- 0.123	F F
147	A B	102613 88572	91402 88426	179829	89914	129889 112117	113816	91958	4.0	- -	S S/F
148	A B	81199 86858	81199 79522	160720	80360	102783 109946	101722	72568	4.5	- -	S/F S/F
149	A B	48324 49258	48324 49222	97545	48773	61169 62352	61738	52435	3.6	0.31 ,340(.147)	F F
150	A B	53960 53810	53960 53810	107770	53885	68304 68113	68209	59260	3.2	- -	S F
151	A B	50266 49289	50266 49289	99555	49777	63628 62391	63009	67912	2.6	0.15	F/S F/S
152	A B	64232 61892	58650 61819	120469	60235	81306 78345	76246	51193	5.0	0.26 0.087	S/F S/F
153	A B	87080 76851	75744 76814	152558	76279	110228 97279	96556	68539	4.8	0.774 0.199	F F/S
154	A B	57472 58835	57188 58114	115302	57651	72749 74474	72976	53801	8.8	0.288	F F
155	A B	63698 60130	63640 60130	123770	61885	80630 76114	78335	52489	7.7	0.263	F F
156	A B	70102 59494	56934 59408	116343	58171	88737 75309	73635	69558	3.4	0.261 ,25(.027)	F/S F/S

Table A.2 Cont. Comprehensive test results and data for No. 8 specimens with two hooks

	Hook	f_{yt} ksi	d_{tr} in.	$A_{tr,l}$ in. ²	N_{tr}	s_{tr} in.	A_{cti} in. ²	N_{cti}	s_{cti} in.	d_s in.	s_s in.	d_{cto} in.	N_{cto}	A_s in. ²	f_{ys} ksi
132	A B	60	0.5	0.20	1	3.00	0.44	4	3.0	0.50	3.00	-	-	3.16	60
133	A B	60	0.38	0.11	2	3.00	2.00	10	3.0	0.50	3.00	-	-	3.16	60
134	A B	60	0.38	0.11	2	3.00	2.00	10	3.0	0.50	3.00	-	-	3.16	60
135	A B	60	0.38	0.11	2	3.00	2.00	10	3.0	0.50	3.00	-	-	3.16	60
136	A B	60	0.38	0.11	2	7.50	2.00	10	2.5	0.50	3.25	0.5	1	3.16	60
137	A B	60	0.38	0.11	2	6.00	0.88	8	3.0	0.50	3.50	0.5	1	3.16	60
138	A B	60	0.38	0.11	2	3.00	-	-	-	0.38	4.00	-	-	3.16	120
139	A B	60	0.38	0.11	2	3.00	-	-	-	0.38	5.00	-	-	3.16	120
140	A B	60	0.38	0.11	2	7.13	1.20	6	4.0	0.50	1.50	-	-	3.16	60
141	A B	60	0.38	0.11	2	7.13	1.20	6	4.0	0.63	3.50	-	-	3.16	60
142	A B	60	0.38	0.11	2	8.00	0.88	8	4.0	0.50	4.00	0.375	2	3.16	60
143	A B	60	0.38	0.11	2	8.00	-	-	-	0.50	2.00	-	-	3.16	60
144	A B	60	0.38	0.11	2	2.67	-	-	-	0.50	2.00	-	-	3.16	60
145	A B	60	0.38	0.11	2	6.00	-	-	-	0.38	2.75	-	-	6.32	60
146	A B	60	0.38	0.11	2	5.50	-	-	-	0.38	4.00	-	-	6.32	60
147	A B	60	0.38	0.11	2	8.00	0.80	4	4.0	0.50	4.00	0.375	1	3.16	60
148	A B	60	0.38	0.11	2	8.00	0.44	4	4.0	0.50	3.00	-	-	3.16	60
149	A B	60	0.38	0.11	2	7.13	1.20	6	4.0	0.50	1.50	-	-	3.16	60
150	A B	60	0.38	0.11	2	7.13	1.20	6	4.0	0.63	3.50	-	-	3.16	60
151	A B	60	0.38	0.11	2	8.00	0.88	8	4.0	0.50	4.00	0.375	2	3.16	60
152	A B	60	0.38	0.11	2	3.50	-	-	-	0.50	3.50	-	-	3.16	60
153	A B	60	0.38	0.11	2	3.50	-	-	-	0.50	3.50	-	-	3.16	60
154	A B	60	0.38	0.11	2	3.00	-	-	-	0.50	4.00	-	-	6.32	120
155	A B	60	0.38	0.11	2	3.00	-	-	-	0.50	4.00	-	-	6.32	120
156	A B	60	0.38	0.11	2	3.00	-	-	-	0.50	3.00	-	-	3.16	60

Table A.2 Cont. Comprehensive test results and data for No. 8 specimens with two hooks

	Specimen	Hook	Bend Angle	Trans. Reinf. Orient.	Hook Bar Type	l_{eh} in.	$l_{eh,avg}$ in.	f'_c psi	Age days	d_b in.
157	8-12-180-2#3-i-2.5-2-11	A B	180°	Para	A1035 ^c	11.1 10.4	10.8	12010	42	1
158	8-12-180-2#3vr-i-2.5-2-11	A B	180°	Perp	A1035 ^b	10.9 10.9	10.9	12010	42	1
159	8-5-180-2#3-i-3.5-2-11	A B	180°	Para	A1035 ^b	10.1 10.6	10.4	4300	6	1
160	8-5-180-2#3-i-3.5-2-14	A B	180°	Para	A1035 ^b	13.5 13.6	13.6	4870	9	1
161	8-15-180-2#3-i-2.5-2-11	A B	180°	Para	A1035 ^b	11.1 11.1	11.1	15550	87	1
162	8-8-90-2#4-i-2.5-2-10	A B	90°	Para	A1035 ^b	8.5 9.3	8.9	8290	16	1
163	8-8-90-2#4-i-3.5-2-10	A B	90°	Para	A1035 ^b	9.0 9.8	9.4	8290	16	1
164	8-5-90-4#3-i-2.5-2-16	B A	90°	Para	A1035 ^b	16.0 16.3	16.1	4810	6	1
165	8-5-90-4#3-i-2.5-2-12.5	A B	90°	Para	A1035 ^b	11.9 11.9	11.9	4980	7	1
166	8-5-90-4#3-i-2.5-2-9.5	A B	90°	Para	A615	9.5 9.5	9.5	5140	8	1
167	8-5-90-5#3-o-2.5-2-10a	A B	90°	Para	A1035 ^a	10.3 10.5	10.4	5270	7	1
168	8-5-90-5#3-o-2.5-2-10b	A B	90°	Para	A1035 ^a	10.5 10.5	10.5	5440	8	1
169	8-5-90-5#3-o-2.5-2-10c	A B	90°	Para	A1035 ^a	11.3 10.5	10.9	5650	9	1
170	8-8-90-5#3-o-2.5-2-8	A B	90°	Para	A1035 ^b	8.3 8.8	8.5	8630	11	1
171	8-8-90-5#3-o-3.5-2-8	A B	90°	Para	A1035 ^b	7.8 8.0	7.9	8810	14	1
172	8-8-90-5#3-o-4-2-8	A B	90°	Para	A1035 ^b	8.5 8.0	8.3	8740	12	1
173	8-5-90-5#3-i-2.5-2-10b	A B	90°	Para	A1035 ^a	10.3 10.5	10.4	5440	8	1
174	8-5-90-5#3-i-2.5-2-10c	A B	90°	Para	A1035 ^a	10.5 10.5	10.5	5650	9	1
175	8-5-90-5#3-i-2.5-2-15	A B	90°	Para	A1035 ^b	15.3 15.8	15.5	4850	7	1
176	8-5-90-5#3-i-2.5-2-13	A B	90°	Para	A1035 ^b	13.8 13.5	13.6	5560	11	1
177	8-5-90-5#3-i-2.5-2-12(1)	A B	90°	Para	A1035 ^c	11.5 11.1	11.3	5090	7	1
178	8-5-90-5#3-i-2.5-2-12	A B	90°	Para	A1035 ^c	11.3 12.3	11.8	5960	7	1
179	8-5-90-5#3-i-2.5-2-12(2)	A B	90°	Para	A1035 ^c	12.4 12.0	12.2	5240	6	1
180	8-5-90-5#3-i-2.5-2-8	A B	90°	Para	A1035 ^c	7.8 7.4	7.6	5240	6	1
181	8-5-90-5#3-i-2.5-2-10a	B	90°	Para	A1035 ^a	10.5	10.5	5270	7	1
182	(2@3) 8-5-90-5#3-i-2.5-2-10 [‡]	A B	90°	Para	A615	10.0 10.5	10.3	4805	12	1

[‡] Specimen contained A1035 Grade 120 for column longitudinal steel

^a Heat 1, ^b Heat 2, ^c Heat 3 as described in Table 2.3

Table A.2 Cont. Comprehensive test results and data for No. 8 specimens with two hooks

	Hook	R_r	b in.	h in.	h_{cl} in.	h_c in.	c_{so} in.	$c_{so,avg}$ in.	c_{th} in.	c_h in.	N_h	Axial Load kips	Long. Reinf. Layout ^o
157	A B	0.073	16.8	13.2	10.5	8.375	2.5 2.6	2.6	2.1 2.8	9.6	2	30	A2
158	A B	0.073	17.1	13.3	10.5	8.375	2.8 2.6	2.7	2.4 2.4	9.8	2	30	A2
159	A B	0.078	18.6	13.0	10.5	8.375	3.4 3.5	3.4	2.9 2.4	9.8	2	80	A2
160	A B	0.078	19.1	16.0	10.5	8.375	3.6 3.8	3.7	2.5 2.4	9.8	2	80	A2
161	A B	0.073	17.3	13.1	10.5	8.375	2.8 2.8	2.8	2.1 2.0	9.8	2	30	A7
162	A B	0.078	17.3	12.0	10.5	8.375	3.0 3.0	3.0	3.5 2.8	9.3	2	30	A2
163	A B	0.078	18.8	12.0	10.5	8.375	3.8 3.9	3.8	3.0 2.3	9.1	2	30	A2
164	B A	0.078	17.3	17.9	10.5	8.375	2.8 3.0	2.9	1.9 1.6	9.5	2	80	A2
165	A B	0.078	17.0	13.9	10.5	8.375	2.5 2.5	2.5	2.0 2.0	10.0	2	80	A2
166	A B	0.078	17.1	11.5	10.5	8.375	2.8 2.9	2.8	2.0 2.0	9.5	2	80	A2
167	A B	0.084	17.1	12.3	10.5	8.375	2.6 2.6	2.6	1.8 2.0	9.9	2	80	A2
168	A B	0.084	17.0	12.5	10.5	8.375	2.5 2.6	2.6	2.0 2.0	9.9	2	80	A2
169	A B	0.084	17.0	12.5	10.5	8.375	2.6 2.5	2.6	1.3 2.0	9.9	2	80	A2
170	A B	0.078	16.8	10.0	10.5	8.375	2.8 2.8	2.8	1.8 1.3	9.3	2	30	A2
171	A B	0.078	18.5	10.0	10.5	8.375	3.5 3.5	3.5	2.3 2.0	9.5	2	30	A2
172	A B	0.078	20.4	10.0	10.5	8.375	3.9 4.5	4.2	1.5 2.0	10.0	2	30	A2
173	A B	0.084	17.3	12.3	10.5	8.375	2.8 2.6	2.7	2.0 1.8	9.9	2	80	A2
174	A B	0.084	17.0	12.5	10.5	8.375	2.5 2.5	2.5	2.0 2.0	10.0	2	80	A2
175	A B	0.078	17.1	17.2	10.5	8.375	2.8 2.5	2.6	1.9 1.4	9.9	2	30	A2
176	A B	0.078	17.1	15.3	10.5	8.375	2.5 2.4	2.4	1.5 1.8	10.3	2	30	A2
177	A B	0.073	16.8	14.1	10.5	8.375	2.5 2.5	2.5	2.6 3.0	9.8	2	30	A2
178	A B	0.073	16.6	14.3	10.5	8.375	2.5 2.4	2.4	3.0 2.0	9.8	2	30	A2
179	A B	0.073	16.1	14.1	10.5	8.375	2.5 2.6	2.6	1.8 2.1	9.0	2	30	A2
180	A B	0.073	16.6	10.3	10.5	8.375	2.8 2.9	2.8	2.6 2.9	9.0	2	30	A2
181	B	0.08	17	12.3	10.5	8.375	2.5	2.5	1.8	9.8	2	80	A2
182	A B	0.073	9.2	12.0	10.5	8.375	2.4 2.8	2.6	2.0 1.5	2.0	2	30	A2

^o Longitudinal column configurations shown in Appendix A, Figures A1 – A16

Table A.2 Cont. Comprehensive test results and data for No. 8 specimens with two hooks

	Hook	T_{max} lb	T_{ind} lb	T_{total} lb	T lb	$f_{su,max}$ psi	f_{su} psi	$f_{s,ACT}$ psi	Joint shear at failure/ $\sqrt{f_{cm}}$	Slip at Failure in.	Failure Type
157	A	73700	63140	129310	64655	93291	81842	84150	3.2	-	F
	B	66170	66170			83759				-	F
158	A	67136	67136	131559	65780	84983	83265	85128	3.2	-	S/F
	B	87053	64423			110194				0.369	F/S
159	A	57158	56965	111737	55869	72352	70720	48595	4.3	0.167	S/F
	B	54943	54772			69548				0.212	S/F
160	A	68293	68293	126934	63467	86446	80338	67605	3.6	-	F/S
	B	90408	58642			114441				-	F/S
161	A	79626	79553	157845	78922	100792	99902	98813	3.4	-	F/S
	B	78291	78291			99103				-	F
162	A	61367	61286	122721	61360	77680	77671	57719	3.9	0.171	F/S
	B	71322	61434			90281				.285(.129)	F/S
163	A	69451	69451	138925	69463	87913	87927	60971	4.1	0.26	S/F
	B	69474	69474			87942				.181(.104)	F/S
164	B	91801	91801	180857	90429	116204	114467	79881	5.1	-	F/S
	A	97200	89056			123038				-	F/S
165	A	83079	68532	137165	68583	105164	86814	59883	5.0	-	F
	B	68634	68634			86878				-	F
166	A	63275	55094	109827	54914	80094	69511	48649	4.7	-	F
	B	54846	54733			69425				-	F/S
167	A	55700	53308	108513	54257	70507	68679	67247	4.3	-	S
	B	55774	55206			70601				0.213	S
168	A	66444	61714	131183	65592	84107	83027	69147	5.1	0.203	F/S
	B	69470	69470			87936				0.235	S/F
169	A	80648	80648	138988	69494	102086	87967	72985	5.3	-	S/F
	B	58800	58340			74430				-	S/F
170	A	56092	56092	115962	57981	71002	73394	70503	4.5	0.253	F/S
	B	66796	59870			84551				.237(.033)	F/S
171	A	53926	53865	109914	54957	68261	69566	65996	3.8	-	F
	B	56134	56048			71055				.251(.249)	F/S
172	A	39553	39553	78142	39071	50067	49457	68864	2.5	0.388	S/F
	B	41461	38589			52483				0.754	F
173	A	78824	75418	139430	69715	99777	88247	68323	5.4	0.129	F/S
	B	66728	64012			84466				-	F
174	A	68947	68071	137674	68837	87275	87136	70469	5.2	-	F/S
	B	69633	69604			88143				-	F/S
175	A	77125	74150	146753	73377	97627	92882	96574	4.3	0.196	F/S
	B	72603	72603			91903				-	F/S
176	A	93116	83412	164752	82376	117868	104273	90710	5.1	-	S/F
	B	81340	81340			102962				-	F/S
177	A	66726	66726	132727	66363	84463	84004	72061	4.8	-	S/F
	B	75878	66001			96048				-	S/F
178	A	84900	*	72000	72000	107468	91139	80992	2.4		S
	B	72000	72000			91139					S
179	A	72359	72321	142939	71470	91593	90468	78770	5.3		F/S
	B	77425	70619			98006					F/S
180	A	48024	47948	94956	47478	60790	60099	48878	4.6		F
	B	47008	47008			59503				0.321	F
181	B	82800	82800	82800	82800	104800	104800	68100	3.4	0.164	F/S
182	A	61451	57620	115845	57922	77787	73319	63438	9.2	0.05	F/S
	B	58224	58224			73702				0.37	F/S

Table A.2 Cont. Comprehensive test results and data for No. 8 specimens with two hooks

	Hook	f_{yt} ksi	d_{tr} in.	$A_{tr,l}$ in. ²	N_{tr}	S_{tr} in.	A_{cti} in. ²	N_{cti}	S_{cti} in.	d_s in.	S_s in.	d_{cto} in.	N_{cto}	A_s in. ²	f_{ys} ksi
157	A B	60	0.38	0.11	2	8.00	-	-	-	0.50	2.00	-	-	3.16	60
158	A B	60	0.38	0.11	2	2.67	-	-	-	0.50	2.00	-	-	3.16	60
159	A B	60	0.38	0.11	2	3.50	-	-	-	0.50	3.50	-	-	3.16	60
160	A B	60	0.38	0.11	2	3.50	-	-	-	0.50	3.50	-	-	3.16	60
161	A B	60	0.38	0.11	2	5.00	-	-	-	0.50	4.00	-	-	4.74	60
162	A B	60	0.5	0.20	2	7.13	1.20	6	4.0	0.50	2.00	-	-	3.16	60
163	A B	60	0.5	0.20	2	7.13	1.20	6	4.0	0.50	2.00	-	-	3.16	60
164	B A	60	0.38	0.11	4	3.00	2.00	10	3.0	0.50	3.00	-	-	3.16	60
165	A B	60	0.38	0.11	4	3.00	2.00	10	3.0	0.50	3.00	-	-	3.16	60
166	A B	60	0.38	0.11	4	3.00	2.00	10	3.0	0.50	3.00	-	-	3.16	60
167	A B	60	0.38	0.11	5	3.00	1.10	10	3.0	0.63	5.00	-	-	3.16	60
168	A B	60	0.38	0.11	5	3.00	1.10	10	3.0	0.63	5.00	-	-	3.16	60
169	A B	60	0.38	0.11	5	3.00	1.10	10	3.0	0.63	5.00	-	-	3.16	60
170	A B	60	0.38	0.11	5	3.00	2.00	10	3.0	0.50	1.75	-	-	3.16	60
171	A B	60	0.38	0.11	5	3.00	2.00	10	3.0	0.50	1.75	-	-	3.16	60
172	A B	60	0.38	0.11	5	3.00	2.00	10	3.0	0.50	1.75	-	-	3.16	60
173	A B	60	0.38	0.11	5	3.00	1.10	10	3.0	0.63	5.00	-	-	3.16	60
174	A B	60	0.38	0.11	5	3.00	1.10	10	3.0	0.63	5.00	-	-	3.16	60
175	A B	60	0.38	0.11	5	3.00	0.55	5	3.0	0.38	3.50	0.375	2	3.16	60
176	A B	60	0.38	0.11	5	3.00	1.00	5	3.0	0.50	3.00	0.375	1	3.16	60
177	A B	60	0.38	0.11	5	3.00	0.55	5	3.0	0.38	3.50	0.5	2	3.16	60
178	A B	60	0.38	0.11	5	3.00	0.55	5	3.0	0.38	3.50	0.5	2	3.16	60
179	A B	60	0.38	0.11	5	3.00	0.55	5	3.0	0.38	3.50	0.375	1	3.16	60
180	A B	60	0.38	0.11	5	3.00	1.55	5	3.0	0.50	3.00	0.5	1	3.16	60
181	B	60	0.375	0.11	5	3.0	1.10	10	3.0	0.63	3.50	-	-	3.16	60
182	A B	60	0.38	0.11	5	3.00	-	-	-	0.38	4.00	-	-	3.16	120

Table A.2 Cont. Comprehensive test results and data for No. 8 specimens with two hooks

	Specimen	Hook	Bend Angle	Trans. Reinf. Orient.	Hook Bar Type	l_{ch} in.	$l_{ch,avg}$ in.	f'_c psi	Age days	d_b in.
183	(2@5) 8-5-90-5#3-i-2.5-2-10 [‡]	A B	90°	Para	A615	9.9 9.5	9.7	4805	12	1
184	8-8-90-5#3-i-2.5-2-8	A B	90°	Para	A1035 ^b	7.3 7.3	7.3	8290	16	1
185	8-8-90-5#3-i-2.5-2-9 [‡]	A B	90°	Para	A615	8.6 9.0	8.8	7710	25	1
186	8-8-90-5#3-i-2.5-9-9 [‡]	A B	90°	Para	A615	9.0 9.3	9.1	7710	25	1
187	(2@3) 8-8-90-5#3-i-2.5-9-9	A B	90°	Para	A615	9.3 9.5	9.4	7440	22	1
188	(2@4) 8-8-90-5#3-i-2.5-9-9	A B	90°	Para	A615	8.9 9.1	9.0	7440	22	1
189	8-12-90-5#3-i-2.5-2-9	A B	90°	Para	A1035 ^b	9.0 9.0	9.0	11160	77	1
190	8-12-90-5#3-i-2.5-2-10	A B	90°	Para	A1035 ^c	9.0 9.9	9.4	11800	38	1
191	8-12-90-5#3-i-2.5-2-12 [‡]	A B	90°	Para	A1035 ^c	12.2 12.3	12.2	11760	34	1
192	8-12-90-5#3vr-i-2.5-2-10	A B	90°	Perp	A1035 ^c	10.3 10.2	10.2	11800	38	1
193	8-12-90-4#3vr-i-2.5-2-10	A B	90°	Perp	A1035 ^c	10.6 10.3	10.4	11850	39	1
194	8-15-90-5#3-i-2.5-2-6	A B	90°	Para	A1035 ^c	6.5 6.1	6.3	15800	60	1
195	8-15-90-5#3-i-2.5-2-10	A B	90°	Para	A1035 ^c	10.6 9.7	10.1	15800	60	1
196	8-5-90-5#3-i-3.5-2-15	A B	90°	Para	A1035 ^b	15.8 15.8	15.8	4850	7	1
197	8-5-90-5#3-i-3.5-2-13	A B	90°	Para	A1035 ^b	13.3 13.0	13.1	5570	12	1
198	8-5-90-5#3-i-3.5-2-12(1)	A B	90°	Para	A1035 ^c	12.8 12.3	12.5	5090	7	1
199	8-5-90-5#3-i-3.5-2-12	A B	90°	Para	A1035 ^c	12.5 11.8	12.1	6440	9	1
200	8-8-90-5#3-i-3.5-2-8	A B	90°	Para	A1035 ^b	8.0 8.0	8.0	7910	15	1
201	8-12-90-5#3-i-3.5-2-9*	A B	90°	Para	A1035 ^b	9.0 9.0	9.0	11160	77	1
202	(2@5) 8-5-180-5#3-i-2.5-2-10 [‡]	A B	180°	Para	A615	10.0 10.3	10.1	5540	17	1
203	8-12-180-5#3-i-2.5-2-10	A B	180°	Para	A1035 ^c	9.9 9.6	9.8	11800	38	1
204	8-12-180-5#3vr-i-2.5-2-10	A B	180°	Perp	A1035 ^c	11.1 10.5	10.8	11800	38	1
205	8-12-180-4#3vr-i-2.5-2-10	A B	180°	Perp	A1035 ^c	10.5 10.0	10.3	11850	39	1
206	8-15-180-5#3-i-2.5-2-9.5	A B	180°	Para	A1035 ^c	9.6 9.8	9.7	15550	87	1
207	8-5-90-4#4s-i-2.5-2-15	A B	90°	Para	A1035 ^b	15.6 15.6	15.6	4810	6	1

[‡] Specimen contained A1035 Grade 120 for column longitudinal steel

^a Heat 1, ^b Heat 2, ^c Heat 3 as described in Table 2.3

Table A.2 Cont. Comprehensive test results and data for No. 8 specimens with two hooks

	Hook	R_r	b in.	h in.	h_{cl} in.	h_c in.	c_{so} in.	$c_{so,avg}$ in.	c_{th} in.	c_h in.	N_h	Axial Load kips	Long. Reinf. Layout ^o
183	A B	0.073	10.9	12.0	10.5	8.375	2.3 2.4	2.3	2.1 2.5	4.3	2	30	A2
184	A B	0.078	16.1	10.0	10.5	8.375	2.9 2.8	2.8	2.8 2.8	8.5	2	30	A2
185	A B	0.073	17.8	11.0	10.5	8.375	2.8 3.3	3.0	2.4 2.0	9.8	2	30	A2
186	A B	0.073	17.3	18.0	10.5	8.375	2.5 2.8	2.6	9.0 8.8	10.0	2	30	A7
187	A B	0.073	9.0	18.0	10.5	8.375	2.5 2.5	2.5	8.8 8.5	2.0	2	30	A7
188	A B	0.073	10.3	18.0	10.5	8.375	2.5 2.5	2.5	9.1 8.9	3.3	2	30	A7
189	A B	0.078	16.6	11.5	10.5	8.375	2.5 2.6	2.6	2.5 2.5	9.5	2	30	A2
190	A B	0.073	16.8	12.2	10.5	8.375	2.6 2.3	2.4	3.2 2.3	9.9	2	30	A2
191	A B	0.073	16.9	14.2	10.5	8.375	2.4 2.5	2.4	2.0 1.9	10.0	2	30	A2
192	A B	0.073	16.6	11.9	10.5	8.375	2.5 2.4	2.4	1.7 1.7	9.8	2	30	A2
193	A B	0.073	16.0	12.4	10.5	8.375	2.5 2.5	2.5	1.8 2.1	9.0	2	30	A2
194	A B	0.073	17.0	8.3	10.5	8.375	2.6 2.6	2.6	1.8 2.2	9.8	2	30	A11
195	A B	0.073	16.7	12.1	10.5	8.375	2.4 2.4	2.4	1.6 2.4	9.9	2	30	A11
196	A B	0.078	19.3	17.0	10.5	8.375	3.6 3.5	3.5	1.3 1.3	10.3	2	30	A2
197	A B	0.078	19.3	15.4	10.5	8.375	3.4 3.5	3.4	2.1 2.4	10.4	2	30	A2
198	A B	0.073	18.7	14.3	10.5	8.375	3.5 3.4	3.5	1.6 2.1	9.8	2	30	A2
199	A B	0.073	18.6	14.2	10.5	8.375	3.4 3.5	3.4	1.7 2.4	9.8	2	30	A2
200	A B	0.078	18.0	10.0	10.5	8.375	3.5 3.6	3.6	2.0 2.0	8.9	2	30	A2
201	A B	0.078	18.1	11.5	10.5	8.375	3.3 3.4	3.3	2.5 2.5	9.5	2	30	A2
202	A B	0.073	11.0	12.0	10.5	8.375	2.5 2.5	2.5	2.0 1.8	4.0	2	30	A10
203	A B	0.073	16.9	12.2	10.5	8.375	2.3 2.8	2.5	2.3 2.6	9.9	2	30	A2
204	A B	0.073	16.8	12.4	10.5	8.375	2.5 2.5	2.5	1.3 1.9	9.8	2	30	A2
205	A B	0.073	17.0	12.3	10.5	8.375	2.8 2.5	2.6	1.8 2.3	9.8	2	30	A2
206	A B	0.073	17.3	11.7	10.5	8.375	2.5 2.8	2.6	2.1 1.9	10.0	2	30	A10
207	A B	0.078	17.0	17.3	10.5	8.375	3.0 2.9	2.9	1.6 1.6	9.1	2	30	A2

^o Longitudinal column configurations shown in Appendix A, Figures A1 – A16

Table A.2 Cont. Comprehensive test results and data for No. 8 specimens with two hooks

	Hook	T_{max} lb	T_{ind} lb	T_{total} lb	T lb	$f_{su,max}$ psi	f_{su} psi	$f_{s,ACI}$ psi	Joint shear at failure/ $\sqrt{f_{cm}}$	Slip at Failure in.	Failure Type
183	A	59715	59715	111921	55960	75589	70836	59957	7.5	0.12	F
	B	52232	52205			66116				66116	0.29
184	A	56006	49326	100532	50266	70893	63628	58938	4.1	0.3	F
	B	51206	51206			64818				64818	.375 (.092)
185	A	64834	64834	128795	64397	82068	81516	69089	4.6	0.047	F
	B	64027	63961			81047				81047	0
186	A	61960	61894	126597	63298	78431	80125	71539	2.8	0.05	F
	B	65209	64703			82543				82543	0
187	A	56456	56420	117585	58792	71463	74421	72200	5.1	0.082	F
	B	61169	61165			77430				77430	-
188	A	55664	55603	114911	57455	70461	72728	69312	4.4	0.117	F
	B	59345	59307			75120				75120	0
189	A	66512	66512	129507	64753	84193	81966	84890	3.9	0.224	F/S
	B	63119	62994			79897				79897	0.252
190	A	66000	64479	129061	64530	83544	81684	91533	3.5	0.44	F/S
	B	64599	64582			81771				81771	0.547
191	A	90544	88954	175422	87711	114613	111027	118308	4.1	-	F/S
	B	86469	86469			109454				109454	-
192	A	59428	59428	120439	60219	75225	76227	99111	3.4	0.236	F
	B	64145	61011			81196				81196	0.246
193	A	80288	59214	118481	59241	101630	74988	81157	3.3	0.123	F/S
	B	59267	59267			75021				75021	0.101
194	A	48315	48315	96998	48499	61158	61391	70845	3.3	-	F
	B	48683	48683			61624				61624	-
195	A	111610	89783	180007	90003	141278	113928	113633	4.3	-	F/S
	B	90223	90223			114207				114207	0.407
196	A	81187	81187	160681	80341	102768	101697	97934	4.3	.214(.026)	S/F
	B	87144	79494			110309				110309	-
197	A	89620	78290	154137	77069	113443	97555	87460	4.2	-	S
	B	75971	75847			96166				96166	-
198	A	78862	78813	152863	76431	99825	96749	79625	4.9	-	S/F
	B	75869	74050			96037				96037	-
199	A	79156	79156	158301	79150	100198	100190	86877	4.5	-	F
	B	79258	79145			100327				100327	0.162
200	A	55391	55391	111619	55810	70116	70645	63527	4.2	-	F
	B	56240	56228			71190				71190	-
201	A	68822	68822	135663	67831	87116	85863	84890	3.7	-	F/S
	B	82227	66841			104084				104084	0.415
202	A	58132	58132	133288	66644	73585	84359	67287	8.2	-	F
	B	75155	75155			95134				95134	0.111
203	A	63041	63041	128214	64107	79798	81148	94564	3.5	-	F/S
	B	81419	65173			103062				103062	0.339
204	A	67538	67538	135560	67780	85491	85798	104869	3.6	-	F
	B	68023	68023			86105				86105	0.321
205	A	69654	69654	138377	69188	88170	87580	79699	3.7	-	F
	B	68753	68723			87030				87030	-
206	A	85951	85951	171901	85951	108798	108798	107512	4.1	-	S
	B	85951	85951			108798				108798	-
207	A	93337	93337	187306	93653	118148	118548	77404	5.6	0.21	S/F
	B	107709	93969			136340				136340	-

Table A.2 Cont. Comprehensive test results and data for No. 8 specimens with two hooks

	Hook	f_{yt} ksi	d_{tr} in.	$A_{tr,t}$ in. ²	N_{tr}	s_{tr} in.	A_{cti} in. ²	N_{cti}	s_{cti} in.	d_s in.	s_s in.	d_{cto} in.	N_{cto}	A_s in. ²	f_{ys} ksi
183	A B	60	0.38	0.11	5	3.00	-	-	-	0.38	4.00	-	-	3.16	120
184	A B	60	0.38	0.11	5	3.00	1.20	6	3.0	0.50	1.50	-	-	3.16	60
185	A B	60	0.38	0.11	5	3.00	-	-	-	0.38	4.00	-	-	3.16	120
186	A B	60	0.38	0.11	5	3.00	-	-	-	0.38	4.00	-	-	4.74	120
187	A B	60	0.38	0.11	5	3.00	-	-	-	0.38	4.00	-	-	4.74	60
188	A B	60	0.38	0.11	5	3.00	-	-	-	0.38	4.00	-	-	4.74	60
189	A B	60	0.38	0.11	5	3.00	0.88	8	4.0	0.50	4.00	0.375	2	3.16	60
190	A B	60	0.38	0.11	5	3.00	-	-	-	0.50	1.75	-	-	3.16	60
191	A B	60	0.38	0.11	5	3.00	-	-	-	0.38	4.00	-	-	3.16	120
192	A B	60	0.38	0.11	5	1.75	-	-	-	0.50	1.75	-	-	3.16	60
193	A B	60	0.38	0.11	4	2.25	-	-	-	0.50	1.75	-	-	3.16	60
194	A B	60	0.38	0.11	5	3.00	-	-	-	0.38	2.75	-	-	6.32	60
195	A B	60	0.38	0.11	5	3.00	-	-	-	0.38	3.00	-	-	6.32	60
196	A B	60	0.38	0.11	5	3.00	0.55	5	3.0	0.38	3.50	0.375	2	3.16	60
197	A B	60	0.38	0.11	5	3.00	1.00	5	3.0	0.50	3.00	0.375	1	3.16	60
198	A B	60	0.38	0.11	5	3.00	0.55	5	3.0	0.38	3.50	0.5	2	3.16	60
199	A B	60	0.38	0.11	5	3.00	0.55	5	3.0	0.38	3.50	0.5	2	3.16	60
200	A B	60	0.38	0.11	5	3.00	1.20	6	3.0	0.50	1.50	-	-	3.16	60
201	A B	60	0.38	0.11	5	3.00	0.88	8	4.0	0.50	4.00	0.375	2	3.16	60
202	A B	60	0.38	0.11	5	3.00	-	-	-	0.50	4.00	-	-	6.32	120
203	A B	60	0.38	0.11	5	3.00	-	-	-	0.50	1.75	-	-	3.16	60
204	A B	60	0.38	0.11	5	1.75	-	-	-	0.50	1.75	-	-	3.16	60
205	A B	60	0.38	0.11	4	2.25	-	-	-	0.50	1.75	-	-	3.16	60
206	A B	60	0.38	0.11	5	3.00	-	-	-	0.50	4.00	-	-	6.32	60
207	A B	60	0.5	0.20	4	4.00	0.88	8	4.0	0.38	3.50	0.375	2	3.16	60

Table A.2 Cont. Comprehensive test results and data for No. 8 specimens with two hooks

	Specimen	Hook	Bend Angle	Trans. Reinf. Orient.	Hook Bar Type	l_{eh} in.	$l_{eh,avg}$ in.	f'_c psi	Age days	d_b in.
208	8-5-90-4#4s-i-2.5-2-12(1)	A B	90°	Para	A1035 ^c	12.3 12.5	12.4	5180	8	1
209	8-5-90-4#4s-i-2.5-2-12	A B	90°	Para	A1035 ^c	12.0 12.6	12.3	6210	8	1
210	8-5-90-4#4s-i-3.5-2-15	A B	90°	Para	A1035 ^b	15.5 15.1	15.3	4810	6	1
211	8-5-90-4#4s-i-3.5-2-12(1)	A B	90°	Para	A1035 ^c	12.0 11.9	11.9	5910	14	1
212	8-5-90-4#4s-i-3.5-2-12	A B	90°	Para	A1035 ^c	12.0 12.5	12.3	5960	7	1

^a Heat 1, ^b Heat 2, ^c Heat 3 as described in Table 2.3

Table A.2 Cont. Comprehensive test results and data for No. 8 specimens with two hooks

	Hook	R_r	b in.	h in.	h_{cl} in.	h_c in.	c_{so} in.	$c_{so,avg}$ in.	c_{th} in.	c_h in.	N_h	Axial Load kips	Long. Reinf. Layout ^o
208	A B	0.073	17.1	14.4	10.5	8.375	2.5 2.6	2.6	2.1 1.9	10.0	2	30	A2
209	A B	0.073	16.6	14.3	10.5	8.375	2.6 2.5	2.6	2.3 1.6	9.5	2	30	A2
210	A B	0.078	19.6	17.3	10.5	8.375	4.1 4.0	4.1	1.8 2.1	9.5	2	30	A2
211	A B	0.073	19.0	14.3	10.5	8.375	3.8 3.5	3.6	2.3 2.4	9.8	2	30	A2
212	A B	0.073	18.3	14.4	10.5	8.375	3.8 3.5	3.6	2.4 1.9	9.0	2	30	A2

^o Longitudinal column configurations shown in Appendix A, Figures A1 – A16

Table A.2 Cont. Comprehensive test results and data for No. 8 specimens with two hooks

	Hook	T_{max} lb	T_{ind} lb	T_{total} lb	T lb	$f_{su,max}$ psi	f_{su} psi	$f_{s,ACI}$ psi	Joint shear at failure/ $\sqrt{f_{cm}}$	Slip at Failure in.	Failure Type
208	A B	100177 90092	91540 90092	181632	90816	126806 114041	114957	63618	6.2	- -	F/S F/S
209	A B	116352 99672	99838 99672	199509	99755	147281 126167	126272	69305	6.5		F/S S/F
210	A B	105974 90156	91613 90118	181730	90865	134144 114121	115019	75856	4.7	- -	F/S S/F
211	A B	115165 92876	113609 77301	190910	95455	145779 117565	120829	65551	5.6	- -	S F/S
212	A B	103861 96919	99392 96919	196312	98156	131470 122683	124248	67551	5.9		S/F F/S

Table A.2 Cont. Comprehensive test results and data for No. 8 specimens with two hooks

	Hook	f_{yt} ksi	d_{tr} in.	$A_{tr,l}$ in.²	N_{tr}	s_{tr} in.	A_{cti} in.²	N_{cti}	s_{cti} in.	d_s in.	s_s in.	d_{cto} in.	N_{cto}	A_s in.²	f_{ys} ksi
208	A B	60	0.5	0.20	4	4.00	1.60	8	4.0	0.50	3.50	0.5	1	3.16	60
209	A B	60	0.5	0.20	4	4.00	1.60	8	4.0	0.50	3.50	0.5	1	3.16	60
210	A B	60	0.5	0.20	4	4.00	0.88	8	4.0	0.38	3.50	0.375	2	3.16	60
211	A B	60	0.5	0.20	4	4.00	1.60	8	4.0	0.50	3.50	0.5	1	3.16	60
212	A B	60	0.5	0.20	4	4.00	1.60	8	4.0	0.50	3.50	0.5	1	3.16	60

Table A.3 Comprehensive test results and data for No. 11 specimens with two hooks

	Specimen	Hook	Bend Angle	Trans. Reinf. Orient.	Hook Bar Type	ℓ_{eh} in.	$\ell_{eh,avg}$ in.	f'_c psi	Age days	d_b in.
213	11-8-90-0-o-2.5-2-25	A B	90°	Para	A1035	25.3 25.1	25.2	9460	9	1.41
214	11-8-90-0-o-2.5-2-17	A B	90°	Para	A1035	16.8 16.4	16.6	9460	9	1.41
215	11-12-90-0-o-2.5-2-17	A B	90°	Para	A1035	17.1 16.6	16.9	11800	36	1.41
216	11-12-180-0-o-2.5-2-17	A B	180°	Para	A1035	16.9 17.3	17.1	11800	36	1.41
217	11-5-90-0-i-2.5-2-14	A B	90°	Para	A615	13.5 15.3	14.4	4910	13	1.41
218	11-5-90-0-i-2.5-2-26	A B	90°	Para	A1035	26.0 26.0	26.0	5360	6	1.41
219	(2@5.35) 11-5-90-0-i-2.5-13-13	A B	90°	Para	A615	14.0 13.9	13.9	5330	11	1.41
220	11-8-90-0-i-2.5-2-17	A B	90°	Para	A1035	17.3 18.0	17.6	9460	9	1.41
221	11-8-90-0-i-2.5-2-21	A B	90°	Para	A1035	20.0 21.1	20.6	7870	6	1.41
222	11-8-90-0-i-2.5-2-17	A B	90°	Para	A1035	16.3 18.1	17.2	8520	7	1.41
223	11-12-90-0-i-2.5-2-17	A B	90°	Para	A1035	16.1 16.9	16.5	11880	35	1.41
224	11-12-90-0-i-2.5-2-17.5	A B	90°	Para	A1035	17.6 17.8	17.7	13330	31	1.41
225	11-12-90-0-i-2.5-2-25	A B	90°	Para	A1035	24.9 24.4	24.6	13330	34	1.41
226	11-15-90-0-i-2.5-2-24	A B	90°	Para	A1035	24.0 24.8	24.4	16180	62	1.41
227	11-15-90-0-i-2.5-2-11	A B	90°	Para	A1035	12.1 11.5	11.8	16180	63	1.41
228	11-15-90-0-i-2.5-2-10‡	A B	90°	Para	A615	9.5 9.5	9.5	14050	76	1.41
229	11-15-90-0-i-2.5-2-15‡	A B	90°	Para	A1035	14.0 14.0	14.0	14050	77	1.41
230	11-5-90-0-i-3.5-2-17	A B	90°	Para	A1035	18.1 17.6	17.9	5600	24	1.41
231	11-5-90-0-i-3.5-2-14	A B	90°	Para	A615	14.8 15.3	15.0	4910	13	1.41
232	11-5-90-0-i-3.5-2-26	A B	90°	Para	A1035	26.3 25.8	26.0	5960	8	1.41
233	11-8-180-0-i-2.5-2-21	A B	180°	Para	A1035	21.3 20.9	21.1	7870	6	1.41
234	11-8-180-0-i-2.5-2-17	A B	180°	Para	A1035	17.8 18.0	17.9	8520	7	1.41
235	11-12-180-0-i-2.5-2-17	A B	180°	Para	A1035	16.6 16.6	16.6	11880	35	1.41
236	11-5-90-1#4-i-2.5-2-17	A B	90°	Para	A1035	17.8 17.6	17.7	5790	25	1.41
237	11-5-90-1#4-i-3.5-2-17	A B	90°	Para	A1035	17.8 17.8	17.8	5790	25	1.41
238	11-5-90-2#3-i-2.5-2-17	A B	90°	Para	A1035	17.4 17.8	17.6	5600	24	1.41

‡ Specimen contained A1035 Grade 120 for column longitudinal steel

Table A.3 Cont. Comprehensive test results and data for No. 11 specimens with two hooks

	Hook	R_r	b in.	h in.	h_{ct} in.	h_c in.	c_{so} in.	$c_{so,avg}$ in.	c_{th} in.	c_h in.	N_h	Axial Load kips	Long. Reinf. Layout ^o
213	A B	0.085	21.9	27.4	19.5	8.375	2.6 2.9	2.8	2.2 2.3	13.6	2	169	A16
214	A B	0.085	21.4	19.3	19.5	8.375	2.5 2.4	2.4	2.6 2.9	13.8	2	116	A16
215	A B	0.085	21.6	19.3	19.5	8.375	2.5 2.5	2.5	2.2 2.7	13.8	2	117	A7
216	A B	0.085	21.3	19.2	19.5	8.375	2.5 2.6	2.5	2.3 1.9	13.4	2	114	A7
217	A B	0.069	21.6	16.0	19.5	8.375	2.8 2.8	2.8	2.5 0.8	13.3	2	97	A7
218	A B	0.085	21.5	28.1	19.5	8.375	2.5 2.9	2.7	2.1 2.1	13.3	2	169	A12
219	A B	0.085	14.1	26.0	19.5	8.375	2.6 2.6	2.6	12.0 12.1	6.2	2	103	A14
220	A B	0.085	21.2	19.3	19.5	8.375	2.5 2.5	2.5	2.0 1.3	13.4	2	114	A16
221	A B	0.085	21.1	23.4	19.5	8.375	2.5 2.8	2.6	3.4 2.3	13.0	2	138	A13
222	A B	0.085	21.3	19.3	19.5	8.375	2.5 2.5	2.5	3.0 1.1	13.5	2	115	A8
223	A B	0.085	21.2	19.3	19.5	8.375	2.5 2.6	2.6	3.1 2.4	13.3	2	114	A13
224	A B	0.085	22.8	19.8	19.5	8.375	3.8 2.5	3.1	2.1 2.0	13.8	2	126	A7
225	A B	0.085	20.9	27.3	19.5	8.375	2.5 2.5	2.5	2.4 2.9	13.1	2	160	A12
226	A B	0.085	21.3	26.0	19.5	8.375	2.5 2.5	2.5	2.0 1.3	13.5	2	155	A11
227	A B	0.085	20.9	13.1	19.5	8.375	2.4 2.8	2.6	1.0 1.6	13.0	2	77	A2
228	A B	0.085	21.9	12.0	19.5	8.375	2.8 2.7	2.7	2.5 2.5	13.6	2	74	A15
229	A B	0.085	21.4	17.0	19.5	8.375	2.8 2.8	2.8	3.0 3.0	13.0	2	102	A15
230	A B	0.085	23.8	20.0	19.5	8.375	4.0 3.9	3.9	1.8 2.5	13.1	2	133	A7
231	A B	0.069	23.7	16.3	19.5	8.375	3.8 3.9	3.8	1.5 1.0	13.3	2	108	A7
232	A B	0.085	23.8	28.4	19.5	8.375	3.8 3.8	3.8	2.1 2.6	13.5	2	189	A12
233	A B	0.085	21.1	23.1	19.5	8.375	2.9 2.4	2.7	1.8 2.2	13.0	2	137	A13
234	A B	0.085	21.4	19.1	19.5	8.375	2.4 2.5	2.4	1.4 1.1	13.8	2	115	A8
235	A B	0.085	21.6	19.2	19.5	8.375	3.0 2.5	2.8	2.5 2.5	13.3	2	116	A13
236	A B	0.085	21.4	19.6	19.5	8.375	2.8 2.8	2.8	1.8 2.0	13.1	2	117	A7
237	A B	0.085	23.6	19.5	19.5	8.375	3.8 3.9	3.8	1.8 1.8	13.1	2	129	A7
238	A B	0.085	21.3	19.6	19.5	8.375	2.5 2.6	2.6	2.3 1.8	13.4	2	117	A7

^o Longitudinal column configurations shown in Appendix A, Figures A1 – A16

Table A.3 Cont. Comprehensive test results and data for No. 11 specimens with two hooks

	Hook	T_{max} lb	T_{ind} lb	T_{total} lb	T lb	$f_{su,max}$ psi	f_{su} psi	$f_{s,ACT}$ psi	Joint shear at failure/ $\sqrt{f_{cm}}$	Slip at Failure in.	Failure Type
213	A	194500	178670	349530	174765	124679	112029	124103	4.1	-	S
	B	170700	170860			109423				-	S
214	A	121403	108779	214417	107209	77822	68723	81606	3.7	-	S/F
	B	105721	105638			67770				-	S/TK
215	A	123725	105010	210804	105402	79311	67565	92862	3.2	0.143	F/TK
	B	105794	105794			67817				-	F/TK
216	A	83343	83343	166986	83493	53425	53521	93894	2.6	-	S/F
	B	90122	83644			57770				-	S
217	A	67249	67249	133180	66590	43108	42686	51027	3.8	0.139	F/S
	B	81430	65931			52199				-	S
218	A	165682	150653	297454	148727	106206	95338	96429	4.6	-	F/S
	B	146801	146801			94103				-	F/S/TK
219	A	58206	58206	121186	60593	37311	38842	51547	3.1	0.2	F
	B	63035	62981			40407				-	F
220	A	131998	131969	264111	132055	84614	84651	86842	4.6	-	F/TK
	B	141233	132141			90534				-	F/TK
221	A	127061	127061	250252	125126	81449	80209	92409	3.9	-	F/TK
	B	147904	123191			94810				-	F
222	A	105626	105537	209557	104779	67709	67166	80368	3.8	-	S
	B	115172	104020			73828				-	F
223	A	148361	148361	268741	134371	95103	86135	91106	4.1	-	S
	B	120380	120380			77167				-	S/F
224	A	125648	125648	249245	124622	80544	79886	103451	3.3	-	S/TK
	B	123622	123597			79245				0.25	S
225	A	205050	201395	399486	199743	131443	128040	144027	4.2	-	S
	B	198110	198091			126994				-	S
226	A	212601	212601	426530	213265	136283	136708	157068	4.2	-	S/TK
	B	231323	213928			148284				-	S/TK
227	A	48563	48563	96252	48126	31130	30850	76117	1.9	-	F/TK
	B	47717	47689			30588				0.252	F
228	A	52097	52097	102962	51481	33395	33001	57045	2.3	-	F
	B	50882	50866			32617				-	F
229	A	93327	93327	184335	92168	59825	59082	84066	2.9	-	S
	B	91008	91008			58339				-	S
230	A	105772	105772	216244	108122	67803	69309	67763	4.2	0.187	S/TK
	B	117570	110472			75366				-	S
231	A	82601	70046	139027	69514	52949	44560	53246	3.5	-	F/S
	B	68982	68982			44219				-	F/S/TK
232	A	198346	183026	364508	182254	127145	116829	101683	4.8	-	S/F
	B	181661	181481			116449				-	F/S
233	A	137773	129406	256246	128123	88316	82130	94656	4.1	-	F
	B	126839	126839			81307				-	F/S
234	A	101710	101710	200907	100453	65199	64393	83583	3.6	-	F
	B	121269	99197			77737				-	F
235	A	106726	106726	214921	107461	68414	68885	91796	3.3	0.156	S/F
	B	108195	108195			69356				-	S
236	A	99443	99403	202995	101498	63746	65063	68180	4.4	-	S/F
	B	119681	103592			76718				-	F/S
237	A	105692	103693	212540	106270	67751	68122	68421	4.2	-	S
	B	108846	108846			69773				-	S/F/TK
238	A	108406	98172	201390	100695	69491	64548	66578	4.4	-	S/F
	B	103234	103218			66176				-	S/F

Table A.3 Cont. Comprehensive test results and data for No. 11 specimens with two hooks

	Hook	f_{yt} ksi	d_{tr} in.	$A_{tr,l}$ in. ²	N_{tr}	s_{tr} in.	A_{cti} in. ²	N_{cti}	S_{cti} in.	d_s in.	s_s in.	d_{cto} in.	N_{cto}	A_s in. ²	f_{ys} ksi
213	A B	60	-	-	-	-	-	-	-	0.50	6.0	-	-	9.48	60
214	A B	60	-	-	-	-	-	-	-	0.50	6.0	-	-	9.48	60
215	A B	60	-	-	-	-	-	-	-	0.50	3.5	-	-	4.74	60
216	A B	60	-	-	-	-	-	-	-	0.50	3.5	-	-	4.74	60
217	A B	60	-	-	-	-	2.4	12	4.0	0.50	4.0	0.375	2	4.74	60
218	A B	60	-	-	-	-	1.86	6	4.0	0.50	4.0	0.375	1	6.32	60
219	A B	60	-	-	-	-	-	-	-	0.50	7.0	-	-	7.90	60
220	A B	60	-	-	-	-	-	-	-	0.50	6.0	-	-	9.48	60
221	A B	60	-	-	-	-	-	-	-	0.50	6.0	-	-	9.40	60
222	A B	60	-	-	-	-	-	-	-	0.50	8.0	-	-	6.28	60
223	A B	60	-	-	-	-	-	-	-	0.50	6.0	-	-	9.40	60
224	A B	60	-	-	-	-	2.4	12	4.0	0.50	4.0	-	-	4.74	60
225	A B	60	-	-	-	-	3.6	18	4.0	0.50	4.0	0.5	1	6.32	60
226	A B	60	-	-	-	-	-	-	-	0.50	3.5	-	-	6.32	60
227	A B	60	-	-	-	-	-	-	-	0.50	3.0	-	-	3.16	60
228	A B	60	-	-	-	-	-	-	-	0.50	4.5	-	-	6.94	120
229	A B	60	-	-	-	-	-	-	-	0.50	4.5	-	-	6.94	120
230	A B	60	-	-	-	-	2.4	12	4.0	0.50	4.0	0.375	2	4.74	60
231	A B	60	-	-	-	-	2.4	12	4.0	0.50	4.0	0.375	2	4.74	60
232	A B	60	-	-	-	-	1.86	6	4.0	0.50	4.0	0.375	1	6.32	60
233	A B	60	-	-	-	-	-	-	-	0.50	6.0	-	-	9.40	60
234	A B	60	-	-	-	-	-	-	-	0.50	8.0	-	-	6.28	60
235	A B	60	-	-	-	-	-	-	-	0.50	6.0	-	-	9.40	60
236	A B	60	0.5	0.20	1	8.75	2.2	11	4.0	0.50	4.0	0.375	2	4.74	60
237	A B	60	0.5	0.20	1	8.75	2.2	11	4.0	0.50	4.0	0.375	2	4.74	60
238	A B	60	0.38	0.11	2	8.00	2	10	4.0	0.50	4.0	0.375	2	4.74	60

Table A.3 Cont. Comprehensive test results and data for No. 11 specimens with two hooks

	Specimen	Hook	Bend Angle	Trans. Reinf. Orient.	Hook Bar Type	l_{eh} in.	$l_{eh,avg}$ in.	f'_c psi	Age days	d_b in.
239	11-5-90-2#3-i-2.5-2-14	A B	90°	Para	A615	13.5 13.8	13.6	4910	13	1.41
240	(2@5.35) 11-5-90-2#3-i-2.5-13-13	A B	90°	Para	A615	13.9 13.8	13.8	5330	11	1.41
241	11-12-90-2#3-i-2.5-2-17.5	A B	90°	Para	A1035	18.0 17.5	17.8	13710	30	1.41
242	11-12-90-2#3-i-2.5-2-25	A B	90°	Para	A1035	25.0 24.5	24.8	13710	30	1.41
243	11-15-90-2#3-i-2.5-2-23	A B	90°	Para	A1035	23.5 23.5	23.5	16180	62	1.41
244	11-15-90-2#3-i-2.5-2-10.5	A B	90°	Para	A1035	11.8 10.5	11.1	16180	63	1.41
245	11-15-90-2#3-i-2.5-2-10*	A B	90°	Para	A615	10.0 10.0	10.0	14045	76	1.41
246	11-15-90-2#3-i-2.5-2-15*	A B	90°	Para	A1035	14.0 14.3	14.1	14045	80	1.41
247	11-5-90-2#3-i-3.5-2-17	A B	90°	Para	A1035	17.5 17.8	17.6	7070	28	1.41
248	11-5-90-2#3-i-3.5-2-14	A B	90°	Para	A615	14.5 13.4	13.9	4910	12	1.41
249	11-5-90-5#3-i-2.5-2-14	A B	90°	Para	A615	14.3 13.5	13.9	4910	12	1.41
250	11-5-90-5#3-i-3.5-2-14	A B	90°	Para	A615	14.6 14.5	14.6	4910	14	1.41
251	11-8-90-6#3-o-2.5-2-16	A B	90°	Para	A1035	15.9 16.5	16.2	9420	8	1.41
252	11-8-90-6#3-o-2.5-2-22	A B	90°	Para	A1035	21.5 22.3	21.9	9120	7	1.41
253	11-12-90-6#3-o-2.5-2-17	A B	90°	Para	A1035	15.6 17.3	16.4	11800	36	1.41
254	11-12-180-6#3-o-2.5-2-17	A B	180°	Para	A1035	16.6 16.4	16.5	11800	36	1.41
255	11-5-90-6#3-i-2.5-2-20	A B	90°	Para	A1035	19.5 19.0	19.3	5420	7	1.41
256	(2@5.35) 11-5-90-6#3-i-2.5-13-13	A B	90°	Para	A615	14.0 13.8	13.9	5280	12	1.41
257	(2@5.35) 11-5-90-6#3-i-2.5-18-18	A B	90°	Para	A1035	19.3 19.5	19.4	5280	12	1.41
258	11-8-90-6#3-i-2.5-2-16	A B	90°	Para	A1035	15.5 16.4	15.9	9120	7	1.41
259	11-8-90-6#3-i-2.5-2-22	A B	90°	Para	A1035	21.3 21.5	21.4	9420	8	1.41
260	11-8-90-6#3-i-2.5-2-22	A B	90°	Para	A1035	21.9 22.0	21.9	9420	8	1.41
261	11-8-90-6#3-i-2.5-2-15	A B	90°	Para	A1035	15.8 15.3	15.5	7500	5	1.41
262	11-8-90-6#3-i-2.5-2-19	A B	90°	Para	A1035	19.1 19.4	19.2	7500	5	1.41
263	11-12-90-6#3-i-2.5-2-17	A B	90°	Para	A1035	17.1 16.5	16.8	12370	37	1.41
264	11-12-90-6#3-i-2.5-2-16	A B	90°	Para	A1035	14.8 16.0	15.4	13710	31	1.41

Table A.3 Cont. Comprehensive test results and data for No. 11 specimens with two hooks

	Hook	R_r	b in.	h in.	h_{cl} in.	h_c in.	c_{so} in.	$c_{so,avg}$ in.	c_{th} in.	c_h in.	N_h	Axial Load kips	Long. Reinf. Layout ^o
239	A B	0.069	21.7	16.0	19.5	8.375	2.8 2.9	2.8	2.5 2.3	13.3	2	97	A7
240	A B	0.085	14.3	26.0	19.5	8.375	2.7 2.6	2.6	12.1 12.3	6.2	2	104	A14
241	A B	0.085	21.1	19.5	19.5	8.375	2.5 2.5	2.5	1.5 2.0	13.3	2	115	A7
242	A B	0.085	21.4	27.3	19.5	8.375	2.6 3.0	2.8	2.3 2.8	13.0	2	164	A12
243	A B	0.085	21.3	25.0	19.5	8.375	2.8 2.8	2.8	1.5 1.5	13.0	2	149	A11
244	A B	0.085	21.8	12.8	19.5	8.375	2.5 2.8	2.6	1.0 2.3	13.8	2	78	A2
245	A B	0.085	22.0	12.0	19.5	8.375	2.8 3.0	2.9	2.0 2.0	13.4	2	74	A15
246	A B	0.085	21.5	17.0	19.5	8.375	2.6 2.6	2.6	3.0 2.8	13.6	2	102	A15
247	A B	0.085	23.4	19.7	19.5	8.375	3.6 3.6	3.6	2.1 2.0	13.4	2	129	A7
248	A B	0.069	23.7	16.1	19.5	8.375	3.8 3.9	3.8	1.6 2.8	13.3	2	107	A7
249	A B	0.069	21.8	16.0	19.5	8.375	2.8 2.9	2.8	1.8 2.5	13.4	2	98	A7
250	A B	0.069	23.7	16.0	19.5	8.375	3.9 3.9	3.9	1.4 1.5	13.1	2	106	A7
251	A B	0.085	21.6	18.1	19.5	8.375	2.5 2.6	2.6	2.3 1.6	13.6	2	109	A16
252	A B	0.085	21.4	24.4	19.5	8.375	2.5 2.6	2.6	2.9 2.1	13.5	2	146	A16
253	A B	0.085	21.4	19.3	19.5	8.375	2.5 2.4	2.4	3.6 2.0	13.8	2	116	A7
254	A B	0.085	21.6	19.5	19.5	8.375	2.5 2.8	2.6	2.9 3.1	13.5	2	118	A7
255	A B	0.085	20.9	22.3	19.5	8.375	2.6 2.6	2.6	2.8 3.3	12.9	2	130	A7
256	A B	0.085	14.2	26.0	19.5	8.375	2.4 2.8	2.6	12.0 12.3	6.2	2	103	A14
257	A B	0.085	14.3	36.0	19.5	8.375	2.7 2.6	2.6	16.8 16.5	6.2	2	144	A14
258	A B	0.085	21.2	18.3	19.5	8.375	2.5 2.5	2.5	2.8 1.9	13.4	2	108	A16
259	A B	0.085	21.4	24.1	19.5	8.375	2.5 2.6	2.6	2.8 2.6	13.5	2	145	A11
260	A B	0.085	21.7	24.2	19.5	8.375	2.6 2.9	2.8	2.3 2.2	13.4	2	147	A16
261	A B	0.085	21.6	17.3	19.5	8.375	2.8 2.5	2.6	1.5 2.0	13.5	2	104	A13
262	A B	0.085	21.4	21.0	19.5	8.375	2.5 2.6	2.6	2.0 1.7	13.5	2	126	A13
263	A B	0.085	21.4	19.1	19.5	8.375	2.6 3.0	2.8	1.9 2.6	13.0	2	114	A13
264	A B	0.085	20.8	18.0	19.5	8.375	2.5 2.5	2.5	3.3 2.0	13.0	2	105	A7

^o Longitudinal column configurations shown in Appendix A, Figures A1 – A16

Table A.3 Cont. Comprehensive test results and data for No. 11 specimens with two hooks

	Hook	T_{max} lb	T_{ind} lb	T_{total} lb	T lb	$f_{su,max}$ psi	f_{su} psi	$f_{s,ACI}$ psi	Joint shear at failure/ $\sqrt{f_{cm}}$	Slip at Failure in.	Failure Type
239	A B	77718 77214	77718 77127	154845	77422	49819 49496	49630	48365	4.4	0.206 -	F/S S
240	A B	68288 70143	68250 69997	138247	69123	43774 44963	44310	51084	3.5	-	F F
241	A B	133178 129868	132555 128223	260779	130389	85371 83249	83583	105286	3.7	- -	S S
242	A B	210112 205996	210112 205996	416108	208054	134687 132049	133368	146807	4.2	- -	BY BY
243	A B	232100 206900	212550 206600	419150	209575	148782 132628	134343	151429	4.2	- -	S S/F
244	A B	50558 49575	50558 49547	100105	50053	32409 31779	32085	71687	1.9	0.249 -	F F/S
245	A B	64250 63631	64250 63631	127881	63940	41186 40789	40987	60036	2.8	-	F F
246	A B	115577 114801	115577 114801	230377	115189	74088 73590	73839	84801	3.6	- -	F/S F/S
247	A B	107807 111480	107807 111480	219287	109644	69107 71462	70284	75074	3.9	- -	S/F/TK S
248	A B	92719 81848	82732 81817	164549	82275	59435 52467	52740	49474	4.2	- -	F/S S/F/TK
249	A B	105597 94115	96267 94072	190339	95170	67690 60330	61006	49252	5.3	0.397 0.375	S/F S/F
250	A B	101315 94663	101315 94663	195979	97989	64946 60682	62814	51693	5.1	-	F/S S/F
251	A B	138900 134714	138793 134714	273507	136753	89038 86355	87662	99487	4.9	- -	S/F S/F
252	A B	186100 170498	170000 170498	340498	170249	119295 109294	109134	132284	4.7	- -	S S/F
253	A B	116430 147268	116390 115367	231757	115878	74635 94403	74281	113068	3.5	- -	F/S S/F
254	A B	130005 113819	112424 113819	226243	113121	83337 72961	72514	113498	3.4	- 0.112	S F/S
255	A B	153119 134977	137617 134927	272543	136272	98153 86524	87354	89741	5.5	0.274 -	F/S F/S
256	A B	83757 95951	83556 95940	179496	89748	53691 61507	57531	63843	4.6	- -	F F
257	A B	118507 128624	116107 127103	243210	121605	75966 82451	77952	89150	4.5	-	F F
258	A B	147508 129692	136385 129586	265971	132986	94556 83136	85247	96379	4.9	- -	F/S F/S
259	A B	204260 183175	186246 182892	369138	184569	130936 117420	118314	131369	5.1	- -	* S
260	A B	197739 191344	190740 191344	382084	191042	126756 122656	122463	134827	5.2	- -	* S/F
261	A B	142278 108021	108602 108021	216623	108312	91204 69245	69431	85001	4.6	- -	S S/F
262	A B	182735 146093	144766 146093	290860	145430	117138 93650	93224	105395	5.1	- -	F/S F/S
263	A B	179693 162285	161019 162277	323295	161648	115188 104029	103620	118408	4.9	0.334 -	F/S S/S
264	A B	115139 127542	115089 115306	230394	115197	73807 81758	73844	113998	3.6	- 0.952	S/F S/F

*Test terminated prior to failure of second hooked bar

Table A.3 Cont. Comprehensive test results and data for No. 11 specimens with two hooks

	Hook	f_{yt} ksi	d_{tr} in.	$A_{tr,l}$ in. ²	N_{tr}	S_{tr} in.	A_{cti} in. ²	N_{cti}	S_{cti} in.	d_s in.	s_s in.	d_{cto} in.	N_{cto}	A_s in. ²	f_{ys} ksi
239	A B	60	0.38	0.11	2	8.00	2.4	12	4.0	0.50	4.0	0.375	2	4.74	60
240	A B	60	0.38	0.11	2	8.00	-	-	-	0.50	7.0	-	-	7.90	60
241	A B	60	0.38	0.11	2	12.00	2.4	12	4.0	0.50	4.0	-	-	4.74	60
242	A B	60	0.38	0.11	2	12.00	3.2	16	4.0	0.50	4.0	0.5	1	6.32	60
243	A B	60	0.38	0.11	2	8.00	-	-	-	0.50	3.0	-	-	6.32	60
244	A B	60	0.38	0.11	2	8.00	-	-	-	0.50	2.8	-	-	3.16	60
245	A B	60	0.38	0.11	2	8.00	-	-	-	0.50	4.5	-	-	6.94	120
246	A B	60	0.38	0.11	2	8.00	-	-	-	0.50	4.5	-	-	6.94	120
247	A B	60	0.38	0.11	2	8.00	2	10	4.0	0.50	4.0	0.375	2	4.74	60
248	A B	60	0.38	0.11	2	8.00	2.4	12	4.0	0.50	4.0	0.375	2	4.74	60
249	A B	60	0.38	0.11	5	4.38	2.4	12	4.0	0.50	4.0	0.375	2	4.74	60
250	A B	60	0.38	0.11	5	4.38	2.4	12	4.0	0.50	4.0	0.375	2	4.74	60
251	A B	60	0.38	0.11	6	4.00	-	-	-	0.50	6.0	-	-	9.48	60
252	A B	60	0.38	0.11	6	4.00	-	-	-	0.50	6.0	-	-	9.48	60
253	A B	60	0.38	0.11	6	4.00	-	-	-	0.50	3.5	-	-	4.74	60
254	A B	60	0.38	0.11	6	4.00	-	-	-	0.50	3.5	-	-	4.74	60
255	A B	60	0.38	0.11	6	4.00	1.2	6	4.0	0.50	4.0	0.375	2	4.74	60
256	A B	60	0.38	0.11	6	4.00	-	-	-	0.50	7.0	-	-	7.90	60
257	A B	60	0.38	0.11	6	4.00	-	-	-	0.50	7.0	-	-	7.90	60
258	A B	60	0.38	0.11	6	4.00	-	-	-	0.50	6.0	-	-	9.48	60
259	A B	60	0.38	0.11	6	4.00	-	-	-	0.50	2.5	-	-	6.32	60
260	A B	60	0.38	0.11	6	4.00	-	-	-	0.50	6.0	-	-	9.48	60
261	A B	60	0.38	0.11	6	4.00	-	-	-	0.50	6.0	-	-	9.40	60
262	A B	60	0.38	0.11	6	4.00	-	-	-	0.50	6.0	-	-	9.40	60
263	A B	60	0.38	0.11	6	4.00	-	-	-	0.50	6.0	-	-	9.40	60
264	A B	60	0.38	0.11	6	4.00	2.4	12	4.0	0.50	4.0	0.375	1	4.74	60

Table A.3 Cont. Comprehensive test results and data for No. 11 specimens with two hooks

	Specimen	Hook	Bend Angle	Trans. Reinf. Orient.	Hook Bar Type	ℓ_{eh} in.	$\ell_{eh,avg}$ in.	f'_c psi	Age days	d_b in.
265	11-12-90-6#3-i-2.5-2-22	A B	90°	Para	A1035	21.9 21.5	21.7	13710	31	1.41
266	11-15-90-6#3-i-2.5-2-22	A B	90°	Para	A1035	22.3 22.4	22.3	16180	62	1.41
267	11-15-90-6#3-i-2.5-2-9.5	A B	90°	Para	A1035	9.0 10.3	9.6	16180	63	1.41
268	11-15-90-6#3-i-2.5-2-10a‡	A B	90°	Para	A615	9.5 10.0	9.8	14045	76	1.41
269	11-15-90-6#3-i-2.5-2-10b‡	A B	90°	Para	A615	9.5 9.8	9.6	14050	77	1.41
270	11-15-90-6#3-i-2.5-2-15‡	A B	90°	Para	A1035	14.5 15.0	14.8	14045	80	1.41
271	11-5-90-6#3-i-3.5-2-20	A B	90°	Para	A1035	20.5 20.3	20.4	5420	7	1.41
272	11-8-180-6#3-i-2.5-2-15	A B	180°	Para	A1035	15.1 15.5	15.3	7500	5	1.41
273	11-8-180-6#3-i-2.5-2-19	A B	180°	Para	A1035	19.6 19.9	19.8	7870	6	1.41
274	11-12-180-6#3-i-2.5-2-17	A B	180°	Para	A1035	16.9 16.5	16.7	12370	37	1.41
275	11-12-180-6#3-i-2.5-2-17	A B	180°	Para	A1035	16.8 16.8	16.8	12370	37	1.41
276	11-5-90-5#4s-i-2.5-2-20	A B	90°	Para	A1035	20.0 20.3	20.1	5420	7	1.41
277	11-5-90-5#4s-i-3.5-2-20	A B	90°	Para	A1035	19.8 19.3	19.5	5960	8	1.41

‡ Specimen contained A1035 Grade 120 for column longitudinal steel

Table A.3 Cont. Comprehensive test results and data for No. 11 specimens with two hooks

	Hook	R_r	b in.	h in.	h_{cl} in.	h_c in.	c_{so} in.	$c_{so,avg}$ in.	c_{th} in.	c_h in.	N_h	Axial Load kips	Long. Reinf. Layout ^o
265	A B	0.085	22.1	24.3	19.5	8.375	2.9 3.1	3.0	2.4 2.8	13.3	2	150	A12
266	A B	0.085	21.8	24.0	19.5	8.375	3.0 2.5	2.8	1.8 1.6	13.5	2	147	A10
267	A B	0.085	21.6	11.5	19.5	8.375	2.5 3.0	2.8	2.5 1.3	13.3	2	69	A2
268	A B	0.085	21.5	12.0	19.5	8.375	2.6 2.8	2.7	2.5 2.0	13.4	2	72	A15
269	A B	0.085	21.4	12.0	19.5	8.375	2.8 2.8	2.8	2.5 2.3	13.0	2	72	A10
270	A B	0.085	21.5	17.0	19.5	8.375	2.6 2.6	2.6	2.5 2.0	13.6	2	102	A15
271	A B	0.085	23.6	22.3	19.5	8.375	3.8 3.9	3.8	1.8 2.0	13.1	2	147	A7
272	A B	0.085	21.8	17.1	19.5	8.375	2.9 3.1	3.0	2.0 1.6	13.0	2	104	A13
273	A B	0.085	21.8	21.2	19.5	8.375	2.9 2.9	2.9	1.5 1.3	13.3	2	129	A13
274	A B	0.085	21.7	19.8	19.5	8.375	2.6 2.8	2.7	2.9 3.3	13.5	2	120	A7
275	A B	0.085	21.4	19.4	19.5	8.375	2.5 2.8	2.6	2.7 2.6	13.4	2	117	A13
276	A B	0.085	21.4	22.3	19.5	8.375	2.5 2.8	2.6	2.3 2.0	13.4	2	134	A7
277	A B	0.085	23.4	22.0	19.5	8.375	3.8 3.8	3.8	2.3 2.8	13.1	2	144	A7

^o Longitudinal column configurations shown in Appendix A, Figures A1 – A16

Table A.3 Cont. Comprehensive test results and data for No. 11 specimens with two hooks

	Hook	T_{max} lb	T_{ind} lb	T_{total} lb	T lb	$f_{su,max}$ psi	f_{su} psi	$f_{s,ACI}$ psi	Joint shear at failure/ $\sqrt{f_{cm}}$	Slip at Failure in.	Failure Type
265	A B	206283 199234	203983 198395	402379	201189	132233 127714	128967	160802	4.4	- -	S/F F
266	A B	204557 195710	200084 195534	395618	197809	131126 125455	126801	179722	4.1	- -	F/S S/F
267	A B	58154 56612	58154 56612	114765	57383	37278 36290	36784	77527	2.5	0.358 -	F F
268	A B	83558 81804	83558 81804	165362	82681	53563 52438	53001	73169	3.7	- -	F F
269	A B	76605 74596	76605 74553	151158	75579	49106 47818	48448	72244	3.4	-	F F
270	A B	145670 144870	145664 144870	290534	145267	93378 92866	93120	110692	4.6	- -	F F
271	A B	150216 135259	136607 135036	271643	135821	96293 86704	87065	94986	4.8	- -	S/F S
272	A B	112423 110981	112423 110933	223356	111678	72066 71142	71588	83973	4.8	- -	S S
273	A B	170000 149000	149000 149000	298000	149000	108974 95513	95513	110947	5.0	- -	F/S F/S
274	A B	123150 117638	115105 117638	232743	116371	78942 75409	74597	117527	3.4	- 0.379	F F/S
275	A B	148872 173034	148872 148484	297356	148678	95431 110919	95306	118188	4.4	- -	F/S S/F
276	A B	141399 161640	141399 140691	282090	141045	90640 103615	90414	75057	5.5	- -	F/S F/S
277	A B	186703 153546	152402 153532	305934	152967	119681 98427	98056	76262	5.3	- -	S/F F/S

Table A.3 Cont. Comprehensive test results and data for No. 11 specimens with two hooks

	Hook	f_{yt} ksi	d_{tr} in.	$A_{tr,l}$ in. ²	N_{tr}	s_{tr} in.	A_{cti} in. ²	N_{cti}	S_{cti} in.	d_s in.	s_s in.	d_{cto} in.	N_{cto}	A_s in. ²	f_{ys} ksi
265	A B	60	0.38	0.11	6	4.00	3.06	12	4.0	0.50	4.0	0.375	2	6.32	60
266	A B	60	0.38	0.11	6	4.00	-	-	-	0.50	3.0	-	-	6.32	60
267	A B	60	0.38	0.11	6	4.00	-	-	-	0.50	2.3	-	-	3.16	60
268	A B	60	0.38	0.11	6	4.00	-	-	-	0.50	4.5	-	-	6.94	120
269	A B	60	0.38	0.11	6	4.00	-	-	-	0.50	4.5	-	-	6.32	120
270	A B	60	0.38	0.11	6	4.00	-	-	-	0.50	4.5	-	-	6.94	120
271	A B	60	0.38	0.11	6	4.00	1.2	6	4.0	0.50	4.0	0.375	2	4.74	60
272	A B	60	0.38	0.11	6	4.00	-	-	-	0.50	6.0	-	-	9.40	60
273	A B	60	0.38	0.11	6	4.00	-	-	-	0.50	6.0	-	-	9.40	60
274	A B	60	0.38	0.11	6	4.00	-	-	-	0.50	3.0	-	-	4.74	60
275	A B	60	0.38	0.11	6	4.00	-	-	-	0.50	6.0	-	-	9.40	60
276	A B	60	0.5	0.20	5	5.00	4	10	5.0	0.50	5.0	0.375	2	4.74	60
277	A B	60	0.5	0.20	5	5.00	4	10	5.0	0.50	5.0	0.375	2	4.74	60

Table A.4 Comprehensive test results and data for No. 5 specimens with closely-spaced hooks

	Specimen	Hook	Bend Angle	Trans. Reinf. Orient.	Hook Bar Type	ℓ_{eh} in.	$\ell_{eh,avg}$ in.	f'_c psi	Age days	d_b in.
278	(4@4) 5-5-90-0-i-2.5-2-6	A B C D	90°	Para	A1035	5.4 5.3 4.8 5.3	5.2	6430	11	0.625
279	(4@4) 5-5-90-0-i-2.5-2-10	A B C D	90°	Para	A1035	9.0 8.0 9.3 9.9	9.0	6470	12	0.625
280	(4@4) 5-8-90-0-i-2.5-2-6	A B C D	90°	Para	A1035	6.3 5.8 5.8 6.0	5.9	6950	18	0.625
281	(4@6) 5-8-90-0-i-2.5-2-6	A B C D	90°	Para	A1035	6.0 6.0 5.8 6.0	5.9	6693	21	0.625
282	(4@6) 5-8-90-0-i-2.5-6-6	A B C D	90°	Para	A1035	6.3 6.3 6.3 6.3	6.3	6693	21	0.625
283	(3@4) 5-8-90-0-i-2.5-2-6	A B C	90°	Para	A1035	6.0 5.6 6.0	5.9	6950	18	0.625
284	(3@6) 5-8-90-0-i-2.5-2-6	A B C	90°	Para	A1035	6.4 5.9 5.8	6.0	6950	18	0.625
285	(4@4) 5-5-90-2#3-i-2.5-2-6	A B C D	90°	Para	A1035	6.3 6.1 6.3 6.4	6.3	6430	11	0.625
286	(4@4) 5-5-90-2#3-i-2.5-2-8	A B C D	90°	Para	A1035	8.4 7.8 8.0 7.8	8.0	6430	11	0.625
287	(3@6) 5-8-90-5#3-i-2.5-2-6.25	A B C	90°	Para	A1035	5.0 6.3 5.3	5.5	10110	196	0.625
288	(3@4) 5-8-90-5#3-i-2.5-2-6 [‡]	A B C	90°	Para	A1035	6.0 6.3 6.0	6.1	6703	22	0.625
289	(3@6) 5-8-90-5#3-i-2.5-2-6 [‡]	A B C	90°	Para	A1035	6.0 6.0 6.0	6.0	6703	22	0.625
290	(4@4) 5-5-90-5#3-i-2.5-2-7	A B C D	90°	Para	A1035	6.6 7.9 7.5 6.5	7.1	6430	11	0.625
291	(4@4) 5-5-90-5#3-i-2.5-2-6	A B C D	90°	Para	A1035	6.0 6.5 6.6 6.3	6.3	6430	11	0.625

[‡] Specimen contained A1035 Grade 120 for column longitudinal steel

Table A.4 Cont. Comprehensive test results and data for No. 5 specimens with closely-spaced hooks

	Hook	R_r	b in.	h in.	h_{cl} in.	h_c in.	c_{so} in.	$c_{so,avg}$ in.	c_{th} in.	c_h in.	N_h	Axial Load kips	Long. Reinf. Layout
278	A B C D	0.073	13.2	8.2	5.3	8.375	2.4 4.9 5.1 2.8	2.6	2.8 2.9 3.4 2.9	1.9 1.9 1.8	4	30	A1
279	A B C D	0.073	13.2	12.3	5.3	8.375	2.6 5.0 5.0 2.8	2.7	3.3 4.3 3.0 2.4	1.8 1.9 1.6 -	4	30	A1
280	A B C D	0.073	12.9	8.0	5.3	8.375	2.5 5.0 5.0 2.5	2.5	1.8 2.3 2.3 2.0	1.9 1.6 1.9 -	4	30	A2
281	A B C D	0.073	17.3	8.0	5.3	8.375	2.7 6.5 6.5 2.7	2.7	2.0 2.0 2.3 2.0	3.1 3.1 3.1 -	4	30	A2
282	A B C D	0.073	17.1	12.0	5.3	8.375	2.5 6.3 6.5 2.7	2.6	5.8 5.8 5.8 5.8	3.1 3.1 3.1 -	4	30	A7
283	A B C	0.073	10.75	8.0	5.3	8.375	2.6 5.6 2.7	2.6	2.0 2.4 2.0	1.8 1.9 -	3	30	A2
284	A B C	0.073	13.25	8.0	5.3	8.375	2.6 6.2 2.7	2.6	1.6 2.1 2.3	3.0 3.1 -	3	30	A2
285	A B C D	0.073	12.9	8.1	5.3	8.375	2.5 5.0 4.8 2.5	2.5	1.9 2.0 1.9 1.8	1.9 1.9 1.6 -	4	30	A1
286	A B C D	0.073	13.0	10.1	5.3	8.375	2.5 5.0 4.9 2.5	2.5	1.8 2.4 2.1 2.4	1.9 1.9 1.8 -	4	30	A1
287	A B C	0.073	12.75	8.8	5.3	8.375	2.5 5.4 2.5	2.5	3.8 2.6 3.6	2.9 3.0 -	3	30	A1
287	A B C	0.073	10.85	8.0	5.3	8.375	2.5 5.0 2.5	2.5	2.0 1.8 2.0	2.1 1.9 -	3	30	A2
288	A B C	0.073	13.38	8.0	5.3	8.375	2.5 5.0 2.5	2.5	2.0 2.0 2.0	3.4 3.1 -	3	30	A2
290	A B C D	0.073	12.5	9.1	5.3	8.375	2.5 4.6 4.6 2.4	2.4	2.5 1.3 1.6 2.6	1.5 2.0 1.6 -	4	30	A1
291	A B C D	0.073	13.1	8.5	5.3	8.375	2.5 5.1 5.0 2.6	2.6	2.5 2.0 1.9 2.3	2.0 1.8 1.8 -	4	30	A1

° Longitudinal column configurations shown in Appendix A, Figures A1 – A16

Table A.4 Cont. Comprehensive test results and data for No. 5 specimens with closely-spaced hooks

	Hook	T_{max} lb	T_{ind} lb	T_{total} lb	T lb	$f_{su,max}$ psi	f_{su} psi	$f_{s,ACI}$ psi	Joint shear at failure/ $\sqrt{f_{cm}}$	Slip at Failure in.	Failure Type
278	A	12150	12150	58167	14542	39194	46909	47396	4.7	-	F
	B	16822	16822			54265				-	F
	C	15517	15510			50055				-	F
	D	13684	13684			44142				-	F
279	A	27937	27938	113608	28402	90119	91619	83022	6.1	-	F
	B	28572	28455			92168				0.358	F
	C	44806	31762			144535				-	F
	D	27649	25453			89190				-	F
280	A	17307	17307	61916	15479	55829	49932	56570	5.0	-	F/S
	B	17615	17430			56823				-	F
	C	14066	13684			45374				-	F
	D	14082	13495			45426				-	F/S
281	A	20647	17356	77211	19303	66603	62267	55514	4.8	-	F
	B	22459	22123			72448				-	F
	C	22914	22649			73916				-	F
	D	15140	15082			48839				-	F
282	A	16185	16185	64205	16051	52210	51778	58436	2.7	-	F/S
	B	14727	14728			47506				-	F
	C	16472	16472			53135				-	F
	D	16819	16819			54255				-	F/S
283	A	18497	18326	50416	16805	59668	54211	55975	4.9	-	F
	B	17550	17370			56613				-	F
	C	14720	14720			47484				-	F
284	A	25526	25526	74657	24886	82342	80277	57166	5.9	-	F
	B	34858	25964			112445				-	F
	C	23167	23167			74732				-	F
285	A	22446	21831	85621	21405	72406	69049	57277	7.1	-	F
	B	22211	18818			71648				0.23	F
	C	24049	23273			77577				-	F
	D	21725	21699			70081				0.484	F
286	A	23977	23111	104069	26017	77345	83926	73028	6.9	-	F
	B	31206	28774			100665				0.365	F
	C	35987	28714			116087				-	F
	D	23712	23469			76490				0.398	F
287	A	27125	27035	77489	25830	87498	83321	79002	4.8	-	F
	B	32375	24934			104436				-	F
	C	27035	25519			87210				-	F
288	A	35751	35751	104667	34889	115326	112545	71151	10.3	-	F
	B	34693	34518			111913				-	F
	C	34397	34397			110958				-	F
289	A	37827	37754	109345	36448	122023	117576	70176	8.7	-	F
	B	34172	34152			110232				-	F
	C	37469	37439			120868				-	F
290	A	27259	26864	108458	27114	87932	87466	65295	8.3	-	F
	B	37030	32039			119452				-	F
	C	29522	29523			95232				-	F
	D	22950	20032			74032				-	F
291	A	24862	24863	103591	25898	80200	83541	58136	8.1	-	F
	B	27208	27018			87768				-	F
	C	26773	26774			86365				0.333	F
	D	26616	24937			85858				-	F

Table A.4 Cont. Comprehensive test results and data for No. 5 specimens with closely-spaced hooks

	Hook	f_{yt} ksi	d_{tr} in.	$A_{tr,l}$ in. ²	N_{tr}	s_{tr} in.	A_{cti} in.	N_{cti}	s_{cti} in.	d_s in.	s_s in.	d_{cto} in.	N_{cto}	A_s in. ²	f_{ys} ksi
278	A B C D	60	-	-	-	-	1.10	10	2.0	0.375	2.5	0.375	1	1.27	60
279	A B C D	60	-	-	-	-	1.10	10	2.0	0.375	3.0	0.500	1	1.27	60
280	A B C D	60	-	-	-	-	-	-	-	0.375	3.0	-	-	3.16	60
281	A B C D	60	-	-	-	-	-	-	-	0.375	3.0	-	-	3.16	60
282	A B C D	60	-	-	-	-	-	-	-	0.375	3.0	-	-	4.74	60
283	A B C	60	-	-	-	-	-	-	-	0.375	3.0	-	-	3.16	60
284	A B C	60	-	-	-	-	-	-	-	0.375	3.0	-	-	3.16	60
285	A B C D	60	0.38	0.11	2	4.0	0.66	6	4.0	0.375	3.0	0.375	2	1.27	60
286	A B C D	60	0.38	0.11	2	5.0	1.20	6	2.5	0.375	3.0	0.500	2	1.27	60
287	A B C	60	0.38	0.11	5	2	-	-	-	0.50	3.0	0.375	1	1.27	60
288	A B C	60	0.38	0.11	5	2	-	-	-	0.38	3.0	-	-	3.16	120
289	A B C	60	0.38	0.11	5	2	-	-	-	0.38	3.0	-	-	3.16	120
290	A B C D	60	0.38	0.11	5	1.8	0.55	5	1.8	0.375	2.8	0.500	2	1.27	60
291	A B C D	60	0.38	0.11	5	2.0	0.55	5	2.0	0.375	3.0	0.375	2	1.27	60

Table A.4 Cont. Comprehensive test results and data for No. 5 specimens with closely-spaced hooks

	Specimen	Hook	Bend Angle	Trans. Reinf. Orient.	Hook Bar Type	l_{eh} in.	$l_{eh,avg}$ in.	f'_c psi	Age days	d_b in.
292	(4@6) 5-8-90-5#3-i-2.5-2-6 [‡]	A B C D	90°	Para	A1035	6.0 6.0 6.0 6.0	6.0	6693	21	0.625
293	(4@6) 5-8-90-5#3-i-2.5-6-6 [‡]	A B C D	90°	Para	A1035	6.8 6.0 6.5 6.3	6.4	6693	21	0.625
294	(4@4) 5-8-90-5#3-i-2.5-2-6 [‡]	A B C D	90°	Para	A1035	5.8 5.5 6.3 6.5	6.0	6703	22	0.625
295	(3@6) 5-8-90-5#3-i-3.5-2-6.25	A B C	90°	Para	A1035	6.3 6.3 6.3	6.3	10110	196	0.625

[‡] Specimen contained A1035 Grade 120 for column longitudinal steel

Table A.4 Cont. Comprehensive test results and data for No. 5 specimens with closely-spaced hooks

	Hook	R_r	b in.	h in.	h_{cl} in.	h_c in.	c_{so} in.	$c_{so,avg}$ in.	c_{th} in.	c_h in.	N_h	Axial Load kips	Long. Reinf. Layout
292	A B C D	0.073	17.8	8.0	5.3	8.375	2.7 6.5 6.5 2.7	2.7	2.0 2.0 2.0 2.0	3.4 3.4 3.1 -	4	30	A2
293	A B C D	0.073	16.8	8.0	5.3	8.375	2.5 6.5 6.5 2.7	2.6	1.3 2.0 1.5 1.8	3.1 3.1 2.9 -	4	30	A7
294	A B C D	0.073	13.1	8.0	5.3	8.375	2.5 5.0 5.0 2.5	2.5	2.3 2.5 1.8 1.5	1.9 1.9 1.9 -	4	30	A2
295	A B C	0.073	15	8.3	5.3	8.375	3.5 6.6 3.8	3.6	2.1 2.1 2.1	2.6 3.3 -	3	30	A1

[°] Longitudinal column configurations shown in Appendix A, Figures A1 – A16

Table A.4 Cont. Comprehensive test results and data for No. 5 specimens with closely-spaced hooks

	Hook	T_{max} lb	T_{ind} lb	T_{total} lb	T lb	$f_{su,max}$ psi	f_{su} psi	$f_{s,ACI}$ psi	Joint shear at failure/ $\sqrt{f_{cm}}$	Slip at Failure in.	Failure Type
292	A	30306	30282	113284	28321	97761	91358	56099	6.8	-	F
	B	30095	30085			97081				-	F
	C	27572	27573			88942				-	F
	D	25343	25344			81752				-	F
293	A	3210	32083	124607	31152	10354	100489	59605	7.9	-	F
	B	29935	29930			96565				-	F
	C	30839	30839			99481				-	F
	D	31800	31755			102581				-	F
294	A	27967	27968	109970	27493	90216	88686	56141	8.9	-	F
	B	27348	27348			88219				-	F
	C	28550	28551			92097				-	F
	D	26208	26103			84542				-	F
295	A	36112	36112	105803	35268	116491	113766	89775	5.9	-	F
	B	33789	33344			108996				-	F
	C	40826	36347			131696				0.454	F

Table A.4 Cont. Comprehensive test results and data for No. 5 specimens with closely-spaced hooks

	Hook	f_{yt} ksi	d_{tr} in.		N_{tr}	s_{tr} in.	A_{cti} in.	N_{cti}	s_{cti} in.	d_s in.	s_s in.	d_{cto} in.	N_{cto}	A_s in. ²	f_{ys} ksi
292	A	60	0.38	0.11	5	1.7	-	-	-	0.375	3.0	-	-	3.16	120
	B														
	C														
	D														
293	A	60	0.38	0.11	5	1.7	-	-	-	0.375	3.0	-	-	4.74	120
	B														
	C														
	D														
294	A	60	0.38	0.11	5	1.7	-	-	-	0.375	3.0	-	-	3.16	120
	B														
	C														
	D														
295	A	60	0.38	0.11	5	2	-	-	-	0.50	3.0	0.375	1	1.27	60
	B														
	C														

Table A.5 Comprehensive test results and data for No. 8 specimens with closely-spaced hooks

	Specimen	Hook	Bend Angle	Trans. Reinf. Orient.	Hook Bar Type	l_{eh} in.	$l_{eh,avg}$ in.	f'_c psi	Age days	d_b in.
296	(3@5.5) 8-5-90-0-i-2.5-2-16	A B C	90°	Para	A1035 ^b	16.5 15.8 16.0	16.1	6255	13	1
297	(3@5.5) 8-5-90-0-i-2.5-2-10	A B C	90°	Para	A1035 ^b	9.0 9.4 9.8	9.4	6461	14	1
298	(3@5.5) 8-5-90-0-i-2.5-2-8 [‡]	A B C	90°	Para	A615	7.5 8.0 8.0	7.8	5730	18	1
299	(3@3) 8-5-90-0-i-2.5-2-10 [‡]	A B C	90°	Para	A615	10.0 10.3 10.0	10.1	4490	10	1
300	(3@5) 8-5-90-0-i-2.5-2-10 [‡]	A B C	90°	Para	A615	10.3 10.1 10.0	10.1	4490	10	1
301	(3@5.5) 8-8-90-0-i-2.5-2-8	A B C	90°	Para	A1035 ^b	7.8 8.8 7.3	7.9	8700	24	1
302	(3@3) 8-8-90-0-i-2.5-9-9	A B C	90°	Para	A615	9.5 9.5 9.3	9.4	7510	21	1
303	(3@4) 8-8-90-0-i-2.5-9-9	A B C	90°	Para	A615	9.3 9.3 9.3	9.3	7510	21	1
304	(3@3) 8-12-90-0-i-2.5-2-12 [‡]	A B C	90°	Para	A1035 ^c	12.1 12.1 12.2	12.1	11040	31	1
305	(3@4) 8-12-90-0-i-2.5-2-12 [‡]	A B C	90°	Para	A1035 ^c	12.9 12.5 12.5	12.6	11440	32	1
306	(3@5) 8-12-90-0-i-2.5-2-12 [‡]	A B C	90°	Para	A1035 ^c	12.3 12.0 12.3	12.2	11460	33	1
307	(4@3) 8-8-90-0-i-2.5-9-9	A B C D	90°	Para	A615	9.4 9.3 9.3 9.6	9.4	7510	21	1
308	(4@4) 8-8-90-0-i-2.5-9-9	A B C D	90°	Para	A615	9.4 9.1 9.0 9.1	9.2	7510	21	1
309	(3@3) 8-5-180-0-i-2.5-2-10 [‡]	A B C	180°	Para	A615	9.8 10.0 9.8	9.8	5260	15	1
310	(3@5) 8-5-180-0-i-2.5-2-10 [‡]	A B C	180°	Para	A615	10.0 10.0 10.0	10.0	5260	15	1
311	(3@5.5) 8-5-90-2#3-i-2.5-2-14	A B C	90°	Para	A1035 ^b	14.6 13.9 14.8	14.4	6460	14	1
312	(3@5.5) 8-5-90-2#3-i-2.5-2-8.5	A B C	90°	Para	A1035 ^b	9.8 8.8 8.9	9.1	6460	14	1

[‡] Specimen contained A1035 Grade 120 for column longitudinal steel

^a Heat 1, ^b Heat 2, ^c Heat 3 as described in Table 2.3

Table A.5 Cont. Comprehensive test results and data for No. 8 specimens with closely-spaced hooks

	Hook	R_r	b in.	h in.	h_{cl} in.	h_c in.	c_{so} in.	$c_{so,avg}$ in.	c_{th} in.	c_h in.	N_h	Axial Load kips	Long. Reinf. Layout
296	A B C	0.078	17.3	18.1	10.5	8.375	2.6 8.0 2.8	2.7	1.6 2.4 2.1	4.4 4.5 -	3	30	A2
297	A B C	0.078	16.9	12.2	10.5	8.375	2.6 7.9 2.5	2.6	3.2 2.8 2.4	4.4 4.4 -	3	30	A2
298	A B C	0.073	17	10.0	10.5	8.375	2.5 8.0 2.5	2.5	2.5 2.0 2.0	4.5 4.5 -	3	30	A10
299	A B C	0.073	12.8	12.0	10.5	8.375	2.6 5.5 2.5	2.6	2.0 1.8 2.0	2.4 2.3 -	3	30	A2
300	A B C	0.073	16	12.0	10.5	8.375	2.3 7.3 2.5	2.4	1.8 1.9 2.0	4.0 4.3 -	3	30	A2
301	A B C	0.078	16.4	10.1	10.5	8.375	3.0 8.2 2.8	2.9	2.4 1.4 2.9	4.3 3.4 -	3	30	A2
302	A B C	0.073	12.3	18.0	10.5	8.375	2.5 5.6 2.5	2.5	8.5 8.5 8.8	2.1 2.1 -	3	30	A7
303	A B C	0.073	14.1	18.0	10.5	8.375	2.5 6.5 2.5	2.5	8.8 8.8 8.8	3.0 3.1 -	3	30	A7
304	A B C	0.073	12.1	14.0	10.5	8.375	2.5 5.4 2.4	2.5	1.8 1.9 1.8	2.1 2.0 -	3	30	A2
305	A B C	0.073	13.9	14.1	10.5	8.375	2.5 6.4 2.5	2.5	1.3 1.6 1.6	2.9 3.0 -	3	30	A2
306	A B C	0.073	15.9	14.0	10.5	8.375	2.4 7.4 2.5	2.4	1.8 2.0 1.8	4.0 4.0 -	3	30	A2
307	A B C D	0.073	15.0	18.0	10.5	8.375	2.5 5.5 5.5 2.5	2.5	8.6 8.8 8.8 8.4	2.0 2.0 2.0 -	4	30	A12
308	A B C D	0.073	18.3	18.0	10.5	8.375	2.5 6.6 6.5 2.5	2.5	8.6 8.9 9.0 8.9	3.1 3.1 3.0 -	4	30	A12
309	A B C	0.073	11.6	12.0	10.5	8.375	2.4 5.4 2.3	2.3	2.3 2.0 2.3	2.0 2.0 -	3	30	A10
310	A B C	0.073	16.5	12.0	10.5	8.375	2.5 7.8 2.5	2.5	2.0 2.0 2.0	4.3 4.3 -	3	30	A10
311	A B C	0.078	17.1	16.1	10.5	8.375	2.8 8.0 2.5	2.6	1.5 2.2 1.3	4.4 4.5 -	3	30	A2
312	A B C	0.078	16.5	10.7	10.5	8.375	2.5 7.8 2.5	2.5	0.9 1.9 1.8	4.3 4.3 -	3	30	A4

^o Longitudinal column configurations shown in Appendix A, Figures A1 – A16

Table A.5 Cont. Comprehensive test results and data for No. 8 specimens with closely-spaced hooks

	Hook	T_{max} lb	T_{ind} lb	T_{total} lb	T lb	$f_{su,max}$ psi	f_{su} psi	$f_{s,ACI}$ psi	Joint shear at failure/ $\sqrt{f_{cm}}$	Slip at Failure in.	Failure Type	
296	A	65266	65265	188393	62798	82615	79491	90858	4.6	-	F	
	B	103741	76608			131318				79491	0.191	F
	C	46521	46520			58887				-	F	
297	A	26783	26683	108161	36054	33903	45637	53826	4.0	-	F	
	B	57434	55164			72701				-	F	
	C	26314	26314			33309				-	F	
298	A	30459	30459	73234	24411	38556	30900	42354	3.4	-	F	
	B	23292	23292			29484				-	F	
	C	19482	19482			24661				0.15	F	
299	A	30671	30671	85439	28480	38824	36050	48261	5.0	0.09	F	
	B	43708	33363			55327				0.12	F	
	C	21404	21405			27094				0	F	
300	A	30145	30145	96899	32300	38158	40886	48357	4.6	0.015	F	
	B	38965	34709			49323				-	F	
	C	3259	32045			4126				-	F	
301	A	41000	37670	113010	37670	51899	47684	52744	4.4	-	F	
	B	41000	37670			51899				-	F	
	C	41000	37670			51899				-	F	
302	A	24580	24580	64314	21438	31114	27137	58289	2.0	-	F	
	B	25019	25019			31670				-	F	
	C	14714	14714			18625				-	F	
303	A	29402	29403	79058	26353	37218	33358	57258	2.2	0.026	F	
	B	27244	27226			34486				-	F	
	C	22429	22429			28391				-	F	
304	A	56490	56461	144116	48039	71506	60808	90999	4.9	0.194	S	
	B	46273	38034			58573				-	F	
	C	55048	49621			69681				-	F	
305	A	56769	56681	167466	55822	71859	70661	96453	4.8	0.255	F/S	
	B	76126	57568			96362				-	F	
	C	57723	53216			73067				-	F/S	
306	A	53307	53307	157056	52352	67477	66268	93033	4.0	-	F	
	B	66123	42900			83700				-	F	
	C	60849	60849			77024				-	F	
307	A	22186	22181	74637	18659	28083	23619	58031	1.9	-	F	
	B	21191	21153			26824				-	F	
	C	18263	18251			23117				-	F	
	D	13052	13052			16521				-	F	
308	A	20362	20362	72146	18036	25775	22831	56677	1.5	-	F	
	B	19012	19012			24066				-	F	
	C	18477	18449			23389				-	F	
	D	14323	14323			18130				-	F	
309	A	37063	37064	141746	47249	46915	59809	50941	8.5	-	F	
	B	59803	59799			75700				-	F	
	C	44883	44884			56814				-	F	
310	A	41465	40204	137789	45930	52487	58139	51804	5.8	-	F	
	B	60400	59739			76456				-	F	
	C	37920	37846			48000				0.123	F	
311	A	66835	66811	171782	57261	84601	72482	82766	4.7	-	F	
	B	65764	42778			83246				-	F	
	C	62311	62193			78875				-	F	
312	A	25157	24718	122656	40885	31844	51754	52387	5.2	0.215	F	
	B	68732	58920			87003				-	F	
	C	39164	39019			49575				-	F	

Table A.5 Cont. Comprehensive test results and data for No. 8 specimens with closely-spaced hooks

	Hook	f_{yt} ksi	d_{tr} in.	$A_{tr,t}$ in. ²	N_{tr}	S_{tr} in.	A_{cti} in.	N_{cti}	S_{cti} in.	d_s in.	s_s in.	d_{cto} in.	N_{cto}	A_s in. ²	f_{ys} ksi
296	A B C	60	-	-	-	-	2.0	10	3	0.50	3.0	0.375	1	3.16	60
297	A B C	60	-	-	-	-	2.0	10	3	0.50	3.0	0.500	1	3.16	60
298	A B C	60	-	-	-	-	-	-	-	0.50	4.0	-	-	6.32	120
299	A B C	60	-	-	-	-	-	-	-	0.38	3.0	-	-	3.16	120
300	A B C	60	-	-	-	-	-	-	-	0.38	4.0	-	-	3.16	120
301	A B C	60	-	-	0	-	2.2	20	3	0.50	1.8	-	-	3.16	60
302	A B C	60	-	-	-	-	-	-	-	0.38	4.0	-	-	4.74	60
303	A B C	60	-	-	-	-	-	-	-	0.38	4.0	-	-	4.74	60
304	A B C	60	0.38	0.11	0	-	-	-	-	0.38	3.0	-	-	3.16	120
305	A B C	60	0.38	0.11	0	-	-	-	-	0.38	3.0	-	-	3.16	120
306	A B C	60	0.38	0.11	0	-	-	-	-	0.38	3.0	-	-	3.16	120
307	A B C D	60	0.38	0.11	0	3.0	-	-	-	0.375	4.0	-	-	6.32	60
308	A B C D	60	0.38	0.11	0	0.0	-	-	-	0.375	4.0	-	-	6.32	60
309	A B C	60	-	0.11	-	-	-	-	-	0.50	4.0	-	-	6.32	120
310	A B C	60	-	0.11	-	-	-	-	-	0.50	3.0	-	-	6.32	120
311	A B C	60	0.38	0.11	2	8	2.0	10	2.5	0.38	3.0	0.500	2	3.16	60
312	A B C	60	0.38	0.11	2	8	2.0	10	2.5	0.38	2.5	0.500	2	1.89	60

Table A.5 Cont. Comprehensive test results and data for No. 8 specimens with closely-spaced hooks

	Specimen	Hook	Bend Angle	Trans. Reinf. Orient.	Hook Bar Type	l_{eh} in.	$l_{eh,avg}$ in.	f'_c psi	Age days	d_b in.
313	(3@5.5) 8-5-90-2#3-i-2.5-2-14(1)	A B C	90°	Para	A1035 ^c	14.7 15.2 14.8	14.9	5450	7	1
314	(3@5.5) 8-5-90-2#3-i-2.5-2-8.5(1)	A B C	90°	Para	A1035 ^c	7.3 8.9 8.4	8.2	5450	7	1
315	(3@3) 8-5-90-2#3-i-2.5-2-10 [‡]	A B C	90°	Para	A615	9.9 10.1 10.0	10.0	4760	11	1
316	(3@5) 8-5-90-2#3-i-2.5-2-10 [‡]	A B C	90°	Para	A615	10.5 10.6 10.4	10.5	4760	11	1
317	(3@3) 8-5-180-2#3-i-2.5-2-10 [‡]	A B C	180°	Para	A615	10.5 10.3 10.0	9.4	5400	16	1
318	(3@5) 8-5-180-2#3-i-2.5-2-10 [‡]	A B C	180°	Para	A615	9.6 9.8 9.8	9.4	5400	16	1
319	(3@5.5) 8-5-90-5#3-i-2.5-2-8	A B C	90°	Para	A1035 ^b	8.0 8.1 7.8	8.0	6620	15	1
320	(3@5.5) 8-5-90-5#3-i-2.5-2-12	A B C	90°	Para	A1035 ^b	12.4 12.1 12.1	12.2	6620	15	1
321	(3@5.5) 8-5-90-5#3-i-2.5-2-8(1)	A B C	90°	Para	A1035 ^c	7.3 8.4 7.3	7.6	5660	8	1
322	(3@5.5) 8-5-90-5#3-i-2.5-2-12(1)	A B C	90°	Para	A1035 ^c	11.4 12.5 12.0	12.0	5660	8	1
323	(3@5.5) 8-5-90-5#3-i-2.5-2-8(2) [‡]	A B C	90°	Para	A615	8.0 8.0 8.5	8.2	5730	18	1
324	(3@3) 8-5-90-5#3-i-2.5-2-10 [‡]	A B C	90°	Para	A615	10.0 9.8 9.9	9.9	4810	12	1
325	(3@5) 8-5-90-5#3-i-2.5-2-10 [‡]	A B C	90°	Para	A615	10.0 10.0 9.8	9.9	4850	13	1
326	(3@3) 8-8-90-5#3-i-2.5-9-9	A B C	90°	Para	A615	9.5 9.0 9.5	9.3	7440	22	1
327	(3@4) 8-8-90-5#3-i-2.5-9-9	A B C	90°	Para	A615	8.9 9.1 9.3	9.1	7440	22	1
328	(3@3) 8-12-90-5#3-i-2.5-2-12 [‡]	A B C	90°	Para	A1035 ^c	11.9 11.9 11.6	11.8	11040	31	1
329	(3@4) 8-12-90-5#3-i-2.5-2-12 [‡]	A B C	90°	Para	A1035 ^c	12.5 12.0 12.5	12.3	11440	32	1

[‡] Specimen contained A1035 Grade 120 for column longitudinal steel

^a Heat 1, ^b Heat 2, ^c Heat 3 as described in Table 2.3

Table A.5 Cont. Comprehensive test results and data for No. 8 specimens with closely-spaced hooks

	Hook	R_r	b in.	h in.	h_{cl} in.	h_c in.	c_{so} in.	$c_{so,avg}$ in.	c_{th} in.	c_h in.	N_h	Axial Load kips	Long. Reinf. Layout
313	A B C	0.073	16.8	16.4	10.5	8.375	2.8 7.9 2.6	2.7	1.7 1.2 1.6	4.2 4.3 -	3	30	A2
314	A B C	0.073	16.8	10.8	10.5	8.375	2.3 7.9 2.6	2.5	3.5 1.8 2.3	4.5 4.3 -	3	30	A2
315	A B C	0.073	12.1	12.0	10.5	8.375	2.6 5.6 2.5	2.6	2.1 1.9 2.0	2.0 2.0 -	3	30	A7
316	A B C	0.073	16.6	12.0	10.5	8.375	2.5 8.0 2.8	2.6	1.5 1.4 1.6	4.5 3.9 -	3	30	A2
317	A B C	0.073	12.3	11.1	10.5	8.375	2.5 5.5 2.8	2.6	1.5 1.8 2.0	2.0 2.0 -	3	30	A10
318	A B C	0.073	16.1	11.7	10.5	8.375	2.5 7.8 2.3	2.4	2.4 2.3 2.3	4.2 4.2 -	3	30	A10
319	A B C	0.078	16.6	10.2	10.5	8.375	2.5 7.6 2.5	2.5	2.2 2.1 2.4	4.1 4.5 -	3	30	A10
320	A B C	0.078	16.8	14.2	10.5	8.375	2.5 7.8 2.5	2.5	1.8 2.1 2.1	4.3 4.5 -	3	30	A1
321	A B C	0.073	16.6	10.1	10.5	8.375	2.9 7.6 2.9	2.9	2.9 1.8 2.9	3.8 4.1 -	3	30	A2
322	A B C	0.073	16.9	14.2	10.5	8.375	2.5 7.8 2.6	2.6	2.8 1.7 2.2	4.3 4.5 -	3	30	A2
323	A B C	0.073	17	10.0	10.5	8.375	2.8 8.0 2.3	2.5	2.0 2.0 1.5	4.5 4.5 -	3	30	A10
324	A B C	0.073	12.3	12.0	10.5	8.375	2.8 5.9 2.3	2.5	2.0 2.3 2.1	2.1 2.1 -	3	30	A7
325	A B C	0.073	16.3	12.0	10.5	8.375	2.5 7.5 2.8	2.6	2.0 2.0 2.3	4.0 4.0 -	3	30	A3
326	A B C	0.073	12	18.0	10.5	8.375	2.5 5.5 2.5	2.5	8.5 9.0 8.5	2.0 2.0 -	3	30	A7
327	A B C	0.073	14	18.0	10.5	8.375	2.5 6.5 2.5	2.5	9.1 8.9 8.8	3.0 3.0 -	3	30	A7
328	A B C	0.073	12	14.1	10.5	8.375	2.5 5.5 2.5	2.5	2.3 2.3 2.5	2.0 2.0 -	3	30	A2
329	A B C	0.073	13.8	14.3	10.5	8.375	2.5 6.3 2.5	2.5	1.8 2.3 1.8	2.8 3.0 -	3	30	A2

° Longitudinal column configurations shown in Appendix A, Figures A1 – A16

Table A.5 Cont. Comprehensive test results and data for No. 8 specimens with closely-spaced hooks

	Hook	T_{max} lb	T_{ind} lb	T_{total} lb	T lb	$f_{su,max}$ psi	f_{su} psi	$f_{s,ACI}$ psi	Joint shear at failure/ $\sqrt{f_{cm}}$	Slip at Failure in.	Failure Type	
313	A	58682	58531	196009	65336	74281	82704	78438	5.8	-	F/TK	
	B	97141	67310			122963				88882	-	F/TK
	C	70217	70168			-				F/TK		
314	A	36593	35595	97104	32368	46320	40972	43284	4.4	-	F	
	B	43607	30047			55199				-	F	
	C	35210	31462			44570				-	F	
315	A	42191	42191	122162	40721	53406	51545	49174	7.4	0.26	F	
	B	4159	41586			5264				-	F	
	C	38385	38385			48589				-	F	
316	A	43315	43030	134004	44668	54829	56542	51745	5.9	0.26	F	
	B	54636	48236			69159				-	F	
	C	42769	42739			54138				-	F	
317	A	59807	59807	163728	54576	75705	69083	49208	9.9	-	F	
	B	56145	56145			71070				-	F	
	C	47776	47776			60476				0.32	F	
318	A	59312	59313	154502	51501	75078	65191	49208	6.8	-	F	
	B	4934	49344			6246				-	F	
	C	45845	45845			58032				0.14	F	
319	A	30586	30530	111379	37126	38716	46995	57814	4.9	0.388	F	
	B	46989	46919			59480				-	F	
	C	34069	33930			43125				-	F	
320	A	60325	60281	198283	66094	76361	83664	88689	6.2	0.198	F	
	B	110823	80058			140282				-	F	
	C	59279	57944			75037				-	F	
321	A	29839	29789	94108	31369	37771	39708	51219	4.5	-	F	
	B	30241	29643			38280				-	F	
	C	34714	34676			43942				0.381	F	
322	A	55543	44226	143554	47851	70308	60571	80327	4.8	-	F	
	B	74581	74581			94406				-	F	
	C	44410	24747			56215				0.927	F	
323	A	57652	57652	143982	47994	72977	60752	55196	6.8	-	F	
	B	43308	43309			54820				-	F	
	C	43030	43021			54468				0.54	F	
324	A	48766	48766	141829	47276	61729	59843	61149	8.4	-	F	
	B	44849	44503			56771				-	F	
	C	48560	48560			61468				0	F	
325	A	58896	58896	183916	61305	74552	77602	61662	8.2	-	F	
	B	63376	55612			80223				-	F	
	C	69408	69408			87858				-	F	
326	A	43346	43346	119286	39762	54868	50332	71880	3.9	-	F	
	B	49666	38730			62868				-	F	
	C	37210	37211			47101				-	F	
327	A	48534	48534	109678	36559	61435	46278	70115	3.1	0.1	F	
	B	38602	30171			48863				-	F	
	C	31956	30973			40451				-	F	
328	A	70368	68183	186619	62206	89073	78742	110622	6.3	0.302	F	
	B	84954	56310			107537				-	F	
	C	62126	62127			78641				0.251	F	
329	A	70706	69965	194819	64940	89501	82202	117781	5.6	0.262	F	
	B	100028	68745			126618				-	F	
	C	63666	56110			80590				0.205	F	

Table A.5 Cont. Comprehensive test results and data for No. 8 specimens with closely-spaced hooks

	Hook	f_{yt} ksi	d_{tr} in.	$A_{tr,l}$ in. ²	N_{tr}	S_{tr} in.	A_{cti} in.	N_{cti}	S_{cti} in.	d_s in.	s_s in.	d_{cto} in.	N_{cto}	A_s in. ²	f_{ys} ksi
313	A B C	60	0.38	0.11	2	6	1.6	8	3	0.38	2.5	0.375	2	3.16	60
314	A B C	60	0.38	0.11	2	6	2.0	10	3	0.50	2.5	0.375	1	3.16	60
315	A B C	60	0.38	0.11	2	3	-	-	-	0.50	5.0	-	-	4.74	120
316	A B C	60	0.38	0.11	2	3	-	-	-	0.38	3.0	-	-	3.16	120
317	A B C	60	0.38	0.11	2	3	-	-	-	0.50	4.0	-	-	6.32	120
318	A B C	60	0.38	0.11	2	3	-	-	-	0.50	3.0	-	-	6.32	120
319	A B C	60	0.38	0.11	5	3	2.0	10	3.3	0.38	2.5	0.500	2	1.89	60
320	A B C	60	0.38	0.11	5	3	2.0	10	3.2	0.38	2.5	0.500	2	1.27	60
321	A B C	60	0.38	0.11	5	3	2.0	10	3	0.50	2.5	0.375	1	3.16	60
322	A B C	60	0.38	0.11	5	3	1.0	5	2.8	0.50	3.5	0.500	1	3.16	60
323	A B C	60	0.38	0.11	5	3	-	-	-	0.50	4.0	-	-	6.32	120
324	A B C	60	0.38	0.11	5	3	-	-	-	0.50	4.0	-	-	4.74	120
325	A B C	60	0.38	0.11	5	3	-	-	-	0.38	3.0	-	-	3.95	120
326	A B C	60	0.38	0.11	5	3	-	-	-	0.38	4.0	-	-	4.74	60
327	A B C	60	0.38	0.11	5	3	-	-	-	0.38	4.0	-	-	4.74	60
328	A B C	60	0.38	0.11	5	3	-	-	-	0.38	3.0	-	-	3.16	120
329	A B C	60	0.38	0.11	5	3	-	-	-	0.38	3.0	-	-	3.16	120

Table A.5 Cont. Comprehensive test results and data for No. 8 specimens with closely-spaced hooks

	Specimen	Hook	Bend Angle	Trans. Reinf. Orient.	Hook Bar Type	l_{eh} in.	$l_{eh,avg}$ in.	f'_c psi	Age days	d_b in.
330	(3@5) 8-12-90-5#3-i-2.5-2-12 [‡]	A B C	90°	Para	A1035 [°]	11.9 12.4 12.3	12.2	11460	33	1
331	(4@3)8-8-90-5#3-i-2.5-9-9	A B C D	90°	Para	A615	9.3 9.3 9.3 9.3	9.3	7440	22	1
332	(4@4) 8-8-90-5#3-i-2.5-9-9	A B C D	90°	Para	A615	9.5 9.5 9.3 9.6	9.5	7440	22	1
333	(3@3) 8-5-180-5#3-i-2.5-2-10 [‡]	A B C	180°	Para	A615	10.1 9.9 9.8	9.9	5540	17	1
334	(3@5) 8-5-180-5#3-i-2.5-2-10 [‡]	A B C	180°	Para	A615	9.9 9.8 9.5	9.7	5540	17	1

[‡] Specimen contained A1035 Grade 120 for column longitudinal steel

[°] Heat 1, ^b Heat 2, ^c Heat 3 as described in Table 2.3

Table A.5 Cont. Comprehensive test results and data for No. 8 specimens with closely-spaced hooks

	Hook	R_r	b in.	h in.	h_{cl} in.	h_c in.	c_{so} in.	$c_{so,avg}$ in.	c_{th} in.	c_h in.	N_h	Axial Load kips	Long. Reinf. Layout
330	A B C	0.073	16	14.1	10.5	8.375	2.5 7.5 2.5	2.5	2.2 1.7 1.8	4.0 4.0 -	3	30	A2
331	A B C D	0.073	15.3	18.0	10.5	8.375	2.5 5.5 5.5 2.5	2.5	8.8 8.8 8.8 8.8	2.0 2.3 2.0 -	4	30	A7
332	A B C D	0.073	18.0	18.0	10.5	8.375	2.5 6.5 6.5 2.5	2.5	8.5 8.5 8.8 8.4	3.0 3.0 3.0 -	4	30	A7
333	A B C	0.073	12.5	12.0	10.5	8.375	2.8 5.8 2.8	2.8	1.9 2.1 2.3	2.0 2.0 -	3	30	A10
334	A B C	0.073	15.8	12.0	10.5	8.375	2.3 7.0 2.8	2.5	2.1 2.3 2.5	3.8 4.0 -	3	30	A10

[°] Longitudinal column configurations shown in Appendix A, Figures A1 – A16

Table A.5 Cont. Comprehensive test results and data for No. 8 specimens with closely-spaced hooks

	Hook	T_{max} lb	T_{ind} lb	T_{total} lb	T lb	$f_{su,max}$ psi	f_{su} psi	$f_{s,ACI}$ psi	Joint shear at failure/ $\sqrt{f_{cm}}$	Slip at Failure in.	Failure Type		
330	A	59447	59447	194282	64761	75249	81976	116689	4.9	-	F		
	B	85455	65587			108171				-		F	
	C	69248	69248			87656				0.18			F
331	A	32930	32930	125763	31441	41683	39798	56990	2.6	-	F		
	B	38749	38749			49049				-		F	
	C	27318	27290			34580				-			F
	D	26809	26794			33936				-			
332	A	33657	33657	117937	29484	42604	37322	58338	9.6	-	F		
	B	30733	30723			38902				-		F	
	C	27886	27886			35299				-			F
	D	25671	25671			32495				-			
333	A	50346	46175	176632	58877	63729	74528	65903	9.6	-	F		
	B	67397	65274			85313				-		F	
	C	66969	65183			84771				0.269			F
334	A	55363	55236	176006	58669	70080	74264	64518	7.6	-	F		
	B	60892	60892			77078				-		F	
	C	59877	59877			75794				0.382			F

Table A.5 Cont. Comprehensive test results and data for No. 8 specimens with closely-spaced hooks

	Hook	f_{jt} ksi	d_{tr} in.	$A_{tr,l}$ in. ²	N_{tr}	S_{tr} in.	A_{cti} in.	N_{cti}	S_{cti} in.	d_s in.	s_s in.	d_{cto} in.	N_{cto}	A_s in. ²	f_{ys} ksi
330	A	60	0.38	0.11	5	3	-	-	-	0.38	3.0	-	-	3.16	120
	B														
	C														
331	A	60	0.38	0.11	5	3.0	-	-	-	0.375	4.0	-	-	4.74	60
	B														
	C														
	D														
332	A	60	0.38	0.11	5	3.0	-	-	-	0.375	4.0	-	-	4.74	60
	B														
	C														
	D														
333	A	60	0.38	0.11	5	3	-	-	-	0.50	4.0	-	-	6.32	120
	B														
	C														
334	A	60	0.38		5	3	-	-	-	0.50	3.0	-	-	6.32	120
	B														
	C														

Table A.6 Comprehensive test results and data for No. 11 specimens with closely-spaced hooks

	Specimen	Hook	Bend Angle	Trans. Reinf. Orient.	Hook Bar Type	l_{eh} in.	$l_{eh,avg}$ in.	f'_c psi	Age days	d_b in.
335	(3@5.35) 11-5-90-0-i-2.5-13-13	A B C	90°	Para	A615	13.8 14.3 13.5	13.8	5330	11	1.41
336	(3@5.35) 11-5-90-2#3-i-2.5-13-13	A B C	90°	Para	A615	14.0 14.0 13.8	13.9	5330	11	1.41
337	(3@5.35) 11-5-90-6#3-i-2.5-13-13	A B C	90°	Para	A615	13.5 13.5 13.8	13.6	5280	12	1.41
338	(3@5.35) 11-5-90-6#3-i-2.5-18-18	A B C	90°	Para	A1035	18.6 18.6 18.6	18.6	5280	12	1.41

Table A.6 Cont. Comprehensive test results and data for No. 11 specimens with closely-spaced hooks

	Hook	R_r	b in.	h in.	h_{cl} in.	h_c in.	c_{so} in.	$c_{so,avg}$ in.	c_{th} in.	c_h in.	N_h	Axial Load kips	Long. Reinf. Layout ^o
335	A B C	0.085	22.3	26.0	19.5	8.375	2.6 10.0 2.6	2.6	12.3 11.8 12.5	6.6 6.3 -	3	162	A14
336	A B C	0.085	21.5	26.0	19.5	8.375	2.6 10.0 2.6	2.6	12.0 12.0 12.3	6.1 6.1 -	3	157	A14
337	A B C	0.085	21.3	26.0	19.5	8.375	2.6 10.0 2.7	2.6	12.5 12.5 12.3	6.0 5.8 -	3	155	A14
338	A B C	0.085	21.2	36.0	19.5	8.375	2.5 10.0 2.8	2.7	17.4 17.4 17.4	6.1 5.6 -	3	214	A14

^o Longitudinal column configurations shown in Appendix A, Figures A1 – A16

Table A.6 Cont. Comprehensive test results and data for No. 11 specimens with closely-spaced hooks

	Hook	T_{max} lb	T_{ind} lb	T_{total} lb	T lb	$f_{su,max}$ psi	f_{su} psi	$f_{s,ACI}$ psi	Joint shear at failure/ $\sqrt{f_{cm}}$	Slip at Failure in.	Failure Type
335	A B C	45416 49897 59323	45405 49897 59215	154517	51506	29113 31985 38028	33016	51162	2.5	0.113 - -	F F F
336	A B C	50926 58487 64473	50926 58487 64349	173762	57921	32645 37492 41329	37129	51470	2.9	- - -	F F F
337	A B C	59664 66536 72350	59647 66536 72350	198533	66178	38246 42651 46378	42422	50001	3.4	- - -	F F F
338	A B C	103312 147805 113923	100804 121063 113733	335601	111867	66226 94747 73027	71710	68559	4.2	- - -	F F F

Table A.6 Cont. Comprehensive test results and data for No. 11 specimens with closely-spaced hooks

	Hook	f_{yt} ksi	d_{tr} in.	$A_{tr,l}$ in. ²	N_{tr}	s_{tr} in.	A_{cti} in.	N_{cti}	s_{cti} in.	d_s in.	s_s in.	d_{cto} in.	N_{cto}	A_s in. ²	f_{ys} ksi
335	A B C	60	-	-	-	-	-	-	-	0.50	7.0	-	-	7.90	60
336	A B C	60	0.38	0.11	2	8	-	-	-	0.50	7.0	-	-	7.90	60
337	A B C	60	0.38	0.11	6	4	-	-	-	0.50	7.0	-	-	7.90	60
338	A B C	60	0.38	0.11	6	4	-	-	-	0.50	7.0	-	-	7.90	60

APPENDIX B: NOTATION AND DATA TABLES USED IN CHAPTER 3

A_h	Bar area of hook
A_{tr}	Total area of transverse steel inside hook region
A_s	Area of longitudinal steel in the column
A_{cti}	Total area of cross-ties inside the hook region
b	Column width
c_b	Clear cover measured from the center of the hook to the side of the column
c_h	Clear spacing between hooked bars, inside-to-inside spacing
c_{so}	Clear cover measured from the side of the hook to the side of the column
$c_{so,avg}$	Average clear cover of the hooked bars
c_{th}	Clear cover measured from the tail of the hook to the back of the column
d_b	Nominal bar diameter of the hooked bar
d_{cto}	Nominal bar diameter of cross-ties outside the hook region
d_{tr}	Nominal bar diameter of transverse reinforcement inside the hook region
d_s	Nominal bar diameter of transverse reinforcing steel outside the hook region
f'_c	Specified concrete compressive strength
f_{cm}	Measured average concrete compressive strength
$f_{s,ACI}$	Stress in hook as calculated by Section 25.4.3.1 of ACI 318-14
$f_{su,ind}$	Stress in hook at failure
f_{su}	Average peak stress in hooked bars at failure
f_{yt}	Nominal yield strength of transverse reinforcement
f_{ys}	Nominal yield strength of longitudinal reinforcing steel in the column
h_c	Width of bearing member flange
h_{cl}	Height measured from the center of the hook to the top of the bearing member flange
h_{cu}	Height measured from the center of the hook to the bottom of the upper compression member
ℓ_{eh}	Embedment length measured from the back of the hook to the front of the column
$\ell_{eh,avg}$	Average embedment length of hooked bars
n	Number of hooked bars confined by N legs
N	Number of legs of confining reinforcement in joint region
N_{cti}	Total number of cross-ties used as supplemental reinforcement inside the hook region
N_{cto}	Number of cross-ties used per layer as supplemental reinforcement outside the hook region and spaced at s_s
N_h	Number of hooked bars loaded simultaneously
N_{tr}	Number of stirrups/ties crossing the hook
T	Average peak load on hooked bars
T_c	Contribution of concrete to hooked bar anchorage capacity
T_{ind}	Peak load on the hooked bar at failure
T_h	Hooked bar anchorage strength
T_s	Contribution of confining steel in joint region to hooked bar anchorage strength
T_{max}	Maximum load on individual hooked bar
T_{total}	Sum of the loads on hooked bars at failure
R_r	Relative rib area
s_{cti}	Center-to-center spacing of cross-ties in the hook region
s_{tr}	Center-to-center spacing of transverse reinforcement in the hook region
s_s	Center-to-center spacing of stirrups/ties outside the hook region
α	Student's t-test significance
ψ_e	Epoxy coating factor as defined in ACI 318-14 Section 25.4.3.2

Ψ_c	Factor for cover as defined in ACI 318-14 Section 25.4.3.2
Ψ_r	Factor for transverse reinforcement in the hook region
Ψ_o	Factor for hooked bar location
Ψ_m	Hooked bar spacing factor

Failure types

F	Front Failure
S	Side Failure
TK	Tail Kickout
FL	Flexural Failure of column
BY	Yield of hooked bars

Specimen identification

(A@B) C-D-E-F#G-H-I-J-Kx(L)

A	Number of hooks in the specimen
B	Clear spacing between hooks in terms of bar diameter (A@B = blank, indicates standard 2-hook specimen)
C	ASTM in.-lb bar size
D	Nominal compressive strength of concrete
E	Angle of bend
F	Number of bars used as transverse reinforcement within the hook region
G	ASTM in.-lb bar size of transverse reinforcement (if D#E = 0 = no transverse reinforcement)
H	Hooked bars placed inside (i) or outside (o) of longitudinal reinforcement
I	Nominal value of c_{so}
J	Nominal value of c_{th}
K	Nominal value of ℓ_{eh}
x	Replication in a series, blank (or a), b, c, etc.
L	Replication not in a series

LONGITUDINAL COLUMN STEEL LAYOUTS

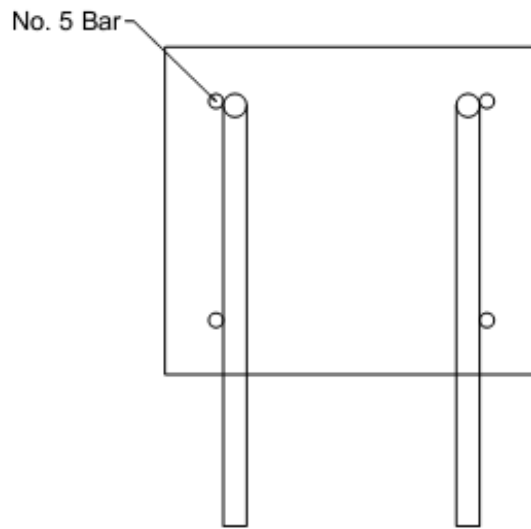

Figure B.1 Longitudinal column reinforcement-4 No. 5 bars. Transverse reinforcement not shown.

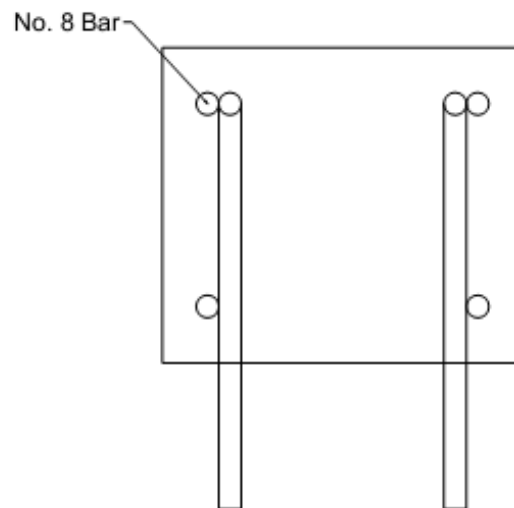

Figure B.2 Longitudinal column reinforcement-4 No. 8 bars. Transverse reinforcement not shown.

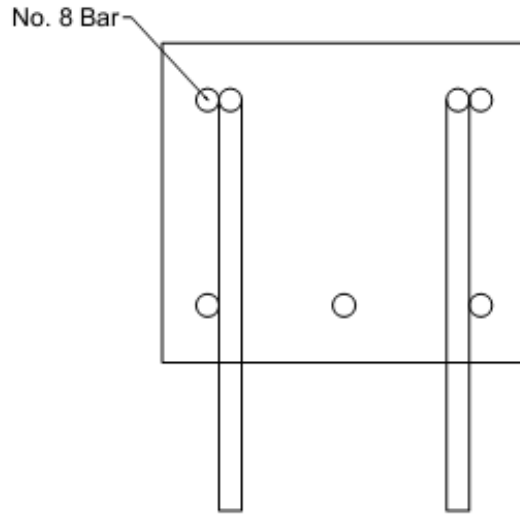

Figure B.3 Longitudinal column reinforcement-5 No. 8 bars. Transverse reinforcement not shown.

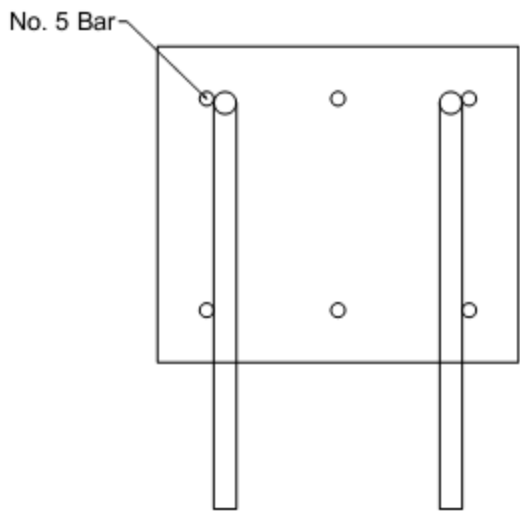

Figure B.4 Longitudinal column reinforcement-6 No. 5 bars. Transverse reinforcement not shown.

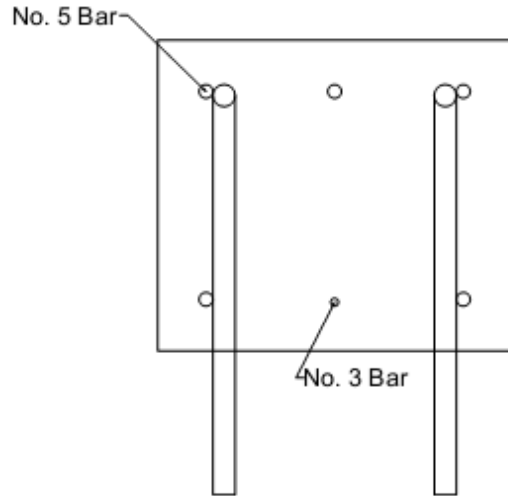

Figure B.5 Longitudinal column reinforcement-5 No. 5 bars + 1 No. 3 bar. Transverse reinforcement not shown.

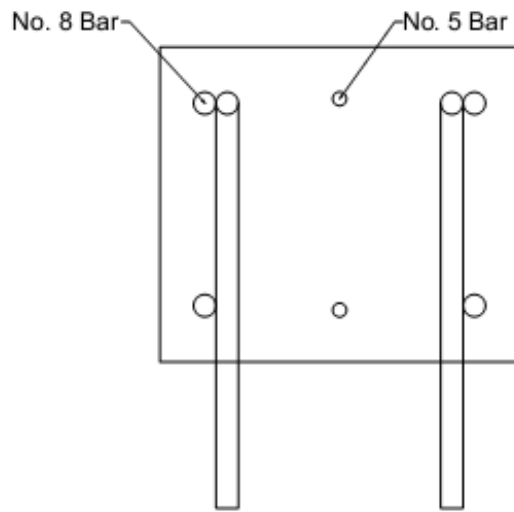

Figure B.6 Longitudinal column reinforcement-4 No. 8 bars + 2 No. 5 bars. Transverse reinforcement not shown.

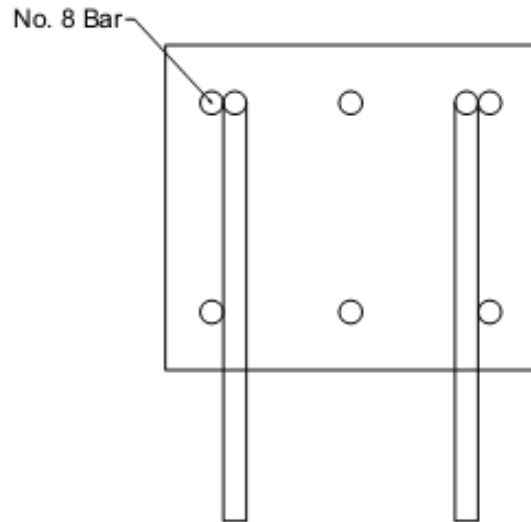

Figure B.7 Longitudinal column reinforcement-6 No. 8 bars. Transverse reinforcement not shown.

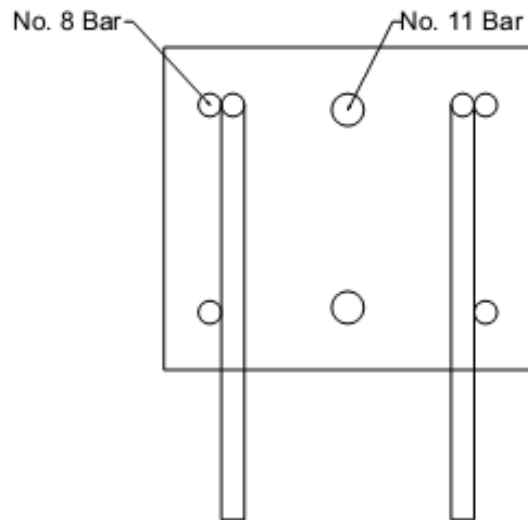

Figure B.8 Longitudinal column reinforcement-4 No. 8 bars + 2 No. 11 bars. Transverse reinforcement not shown.

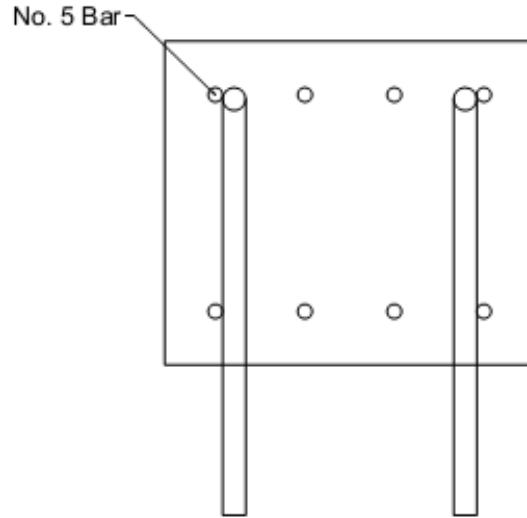

Figure B.9 Longitudinal column reinforcement-8 No. 5 bars. Transverse reinforcement not shown.

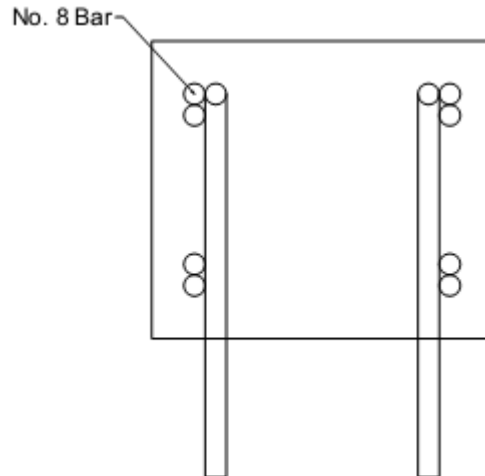

Figure B.10 Longitudinal column reinforcement-8 No. 8 bars (four bundles of two bars each). Transverse reinforcement not shown.

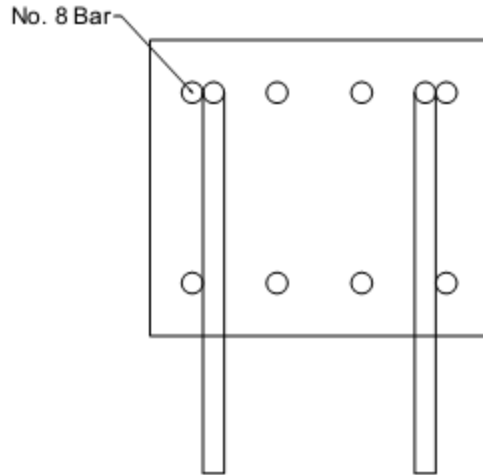

Figure B.11 Longitudinal column reinforcement-8 No. 8 bars (distributed across two column faces). Transverse reinforcement not shown.

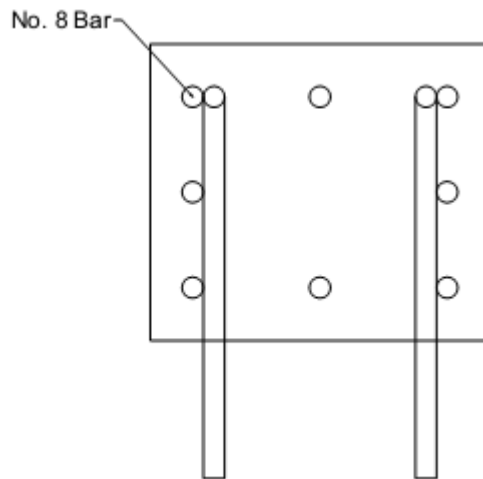

Figure B.12 Longitudinal column reinforcement-8 No. 8 bars (distributed across four column faces). Transverse reinforcement not shown.

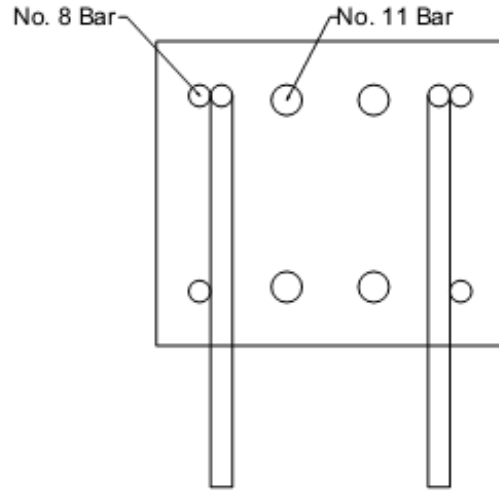

Figure B.13 Longitudinal column reinforcement-4 No. 8 bars + 4 No. 11 bars. Transverse reinforcement not shown.

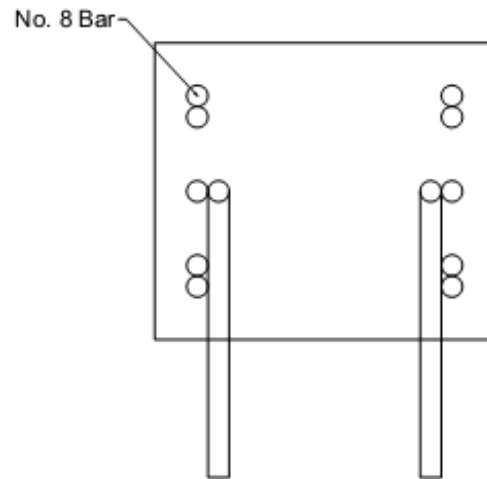

Figure B.14 Longitudinal column reinforcement-10 No. 8 bars. Transverse reinforcement not shown.

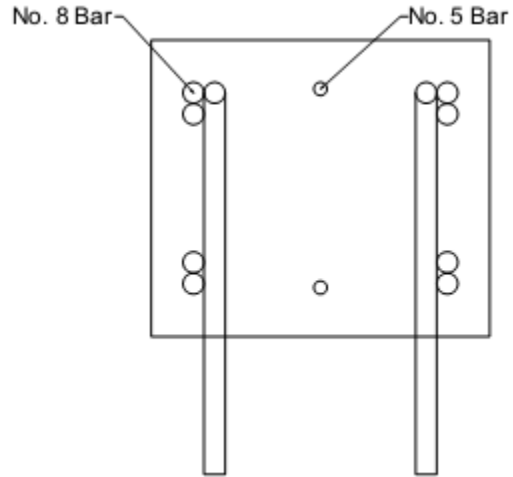

Figure B.15 Longitudinal column reinforcement-8 No. 8 bars + 2 No. 5 bars. Transverse reinforcement not shown.

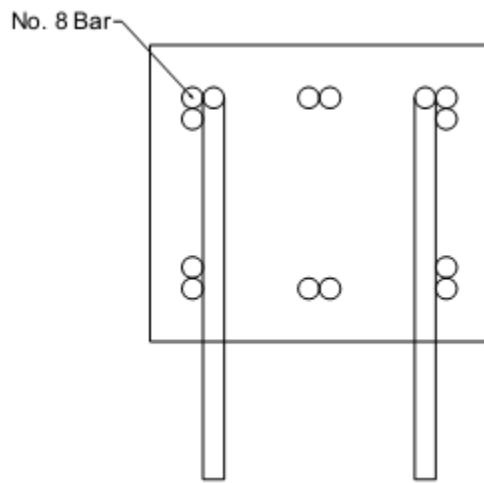

Figure B.16 Longitudinal column reinforcement-12 No. 8 bars. Transverse reinforcement not shown.

Table B.1 Comprehensive test results and data for No. 5 specimens with two hooks

	Specimen	Hook	Bend Angle	Trans. Reinf. Orient.	Hook Bar Type	ℓ_{ch} in.	$\ell_{ch,avg}$ in.	f'_c psi	Age days	d_b in.
1	5-5-90-0-o-1.5-2-5	A B	90°	Para	A615	5.0 5.0	5.0	4930	4	0.625
2	5-5-90-0-o-1.5-2-6.5	A B	90°	Para	A1035	6.5 5.9	6.2	5650	6	0.625
3	5-5-90-0-o-1.5-2-8	B	90°	Para	A1035	7.9	7.9	5650	6	0.625
4	5-5-90-0-o-2.5-2-5	A B	90°	Para	A615	4.8 4.8	4.8	4930	4	0.625
5	5-5-90-0-o-2.5-2-8	A	90°	Para	A1035	9.0	9.0	5780	7	0.625
6	5-5-180-0-o-1.5-2-9.5	A B	180°	Para	A1035	9.6 9.3	9.4	4420	7	0.625
7	5-5-180-0-o-1.5-2-11.25	A	180°	Para	A1035	11.3	11.3	4520	8	0.625
8	5-5-180-0-o-2.5-2-9.5	A B	180°	Para	A1035	9.5 9.5	9.5	4520	8	0.625
9	5-5-90-0-i-2.5-2-10	A B	90°	Para	A1035	9.4 9.4	9.4	5230	6	0.625
10	5-5-90-0-i-2.5-2-7	A B	90°	Para	A1035	6.9 7.0	6.9	5190	7	0.625
11	5-8-90-0-i-2.5-2-6	A B	90°	Para	A615	6.8 6.8	6.8	8450	14	0.625
12	5-8-90-0-i-2.5-2-6(1)	A B	90°	Para	A1035	6.1 6.5	6.3	9080	11	0.625
13	5-8-90-0-i-2.5-2-8	A B	90°	Para	A1035	8.0 7.5	7.8	8580	15	0.625
14	(2@4) 5-8-90-0-i-2.5-2-6	A B	90°	Para	A1035	5.8 6.0	5.9	6950	18	0.625
15	(2@6) 5-8-90-0-i-2.5-2-6	A B	90°	Para	A1035	6.0 6.0	6.0	6950	18	0.625
16	5-12-90-0-i-2.5-2-10	A B	90°	Para	A1035	10.0 11.0	10.5	10290	14	0.625
17	5-12-90-0-i-2.5-2-5	A B	90°	Para	A1035	5.1 4.8	4.9	11600	84	0.625
18	5-15-90-0-i-2.5-2-5.5	A B	90°	Para	A1035	6.1 5.8	5.9	15800	62	0.625
19	5-15-90-0-i-2.5-2-7.5	A B	90°	Para	A1035	7.3 7.3	7.3	15800	62	0.625
20	5-5-90-0-i-3.5-2-10	A B	90°	Para	A1035	10.5 10.4	10.4	5190	7	0.625
21	5-5-90-0-i-3.5-2-7	A B	90°	Para	A1035	7.5 7.6	7.6	5190	7	0.625
22	5-8-90-0-i-3.5-2-6	A B	90°	Para	A615	6.3 6.4	6.3	8580	15	0.625
23	5-8-90-0-i-3.5-2-6(1)	A B	90°	Para	A1035	6.5 6.6	6.6	9300	13	0.625
24	5-8-90-0-i-3.5-2-8	A B	90°	Para	A1035	8.6 8.5	8.6	8380	13	0.625
25	5-12-90-0-i-3.5-2-5	A B	90°	Para	A1035	5.5 5.4	5.4	10410	15	0.625
26	5-12-90-0-i-3.5-2-10	A B	90°	Para	A1035	10.1 10.0	10.1	11600	84	0.625

Table B.1 Cont. Comprehensive test results and data for No. 5 specimens with two hooks

	Hook	R_r	b in.	h in.	h_{cl} in.	h_c in.	c_{so} in.	$c_{so,avg}$ in.	c_{th} in.	c_h in.	N_h	Axial Load kips	Long. Reinf. Layout ^o
1	A B	0.077	11.3	7.0	5.25	8.375	1.5 1.8	1.6	2.0 2.0	6.8	2	80	A1
2	A B	0.073	11.0	8.6	5.25	8.375	1.5 1.6	1.6	2.0 2.8	6.6	2	80	A4
3	B	0.073	11.9	10.0	5.25	8.375	1.5	1.5	2.1	6.6	2	80	A1
4	A B	0.077	12.6	6.9	5.25	8.375	2.5 2.5	2.5	2.1 2.1	6.4	2	80	A1
5	A	0.073	12.1	10.8	5.25	8.375	2.6	2.6	1.5	6.6	2	80	A1
6	A B	0.077	10.9	11.6	5.25	8.375	1.6 1.6	1.6	2.1 2.1	6.4	2	80	A1
7	A	0.077	11.4	13.3	5.25	8.375	1.8	1.8	2.3	6.6	2	80	A1
8	A B	0.077	12.9	11.3	5.25	8.375	2.5 2.5	2.5	1.9 1.8	6.6	2	80	A4
9	A B	0.073	13.1	12.3	5.25	8.375	2.8 2.6	2.7	2.9 2.9	6.4	2	30	A4
10	A B	0.073	13.0	9.6	5.25	8.375	2.5 2.5	2.5	2.8 2.6	6.8	2	30	A1
11	A B	0.073	13.0	8.0	5.25	8.375	2.8 2.6	2.7	1.3 1.3	6.4	2	80	A1
12	A B	0.073	13.3	8.8	5.25	8.375	2.5 2.5	2.5	2.6 2.3	7.0	2	30	A1
13	A B	0.073	13.1	10.0	5.25	8.375	2.5 2.8	2.6	2.0 2.5	6.6	2	80	A1
14	A B	0.073	9.5	8.0	5.25	8.375	2.7 3.7	3.2	2.3 2.0	1.9	2	30	A2
15	A B	0.073	9.6	8.0	5.25	8.375	2.6 2.7	2.6	2.0 2.0	3.1	2	30	A2
16	A B	0.073	12.8	12.5	5.25	8.375	2.4 2.5	2.4	2.5 1.5	6.6	2	30	A4
17	A B	0.073	13.0	7.3	5.25	8.375	2.6 2.6	2.6	2.1 2.5	6.5	2	30	A1
18	A B	0.073	12.6	7.7	5.25	8.375	2.4 2.4	2.4	1.6 1.9	6.6	2	30	A1
19	A B	0.073	12.9	9.8	5.25	8.375	2.5 2.5	2.5	2.6 2.6	6.6	2	30	A2
20	A B	0.073	14.8	12.3	5.25	8.375	3.5 3.5	3.5	1.8 1.9	6.5	2	30	A4
21	A B	0.073	15.1	8.8	5.25	8.375	3.4 3.5	3.4	1.3 1.1	7.0	2	30	A1
22	A B	0.073	15.0	8.0	5.38	8.375	3.6 3.5	3.6	1.8 1.6	6.6	2	80	A1
23	A B	0.073	15.6	8.6	5.25	8.375	3.8 3.8	3.8	2.1 1.9	6.9	2	30	A1
24	A B	0.060	15.5	10.0	5.25	8.375	3.6 3.5	3.6	1.4 1.5	7.1	2	80	A1
25	A B	0.073	15.5	7.2	5.25	8.375	3.6 3.6	3.6	1.7 1.8	7.0	2	30	A1
26	A B	0.073	15.0	12.1	5.25	8.375	3.5 3.5	3.5	2.5 1.5	6.8	2	30	A4

^o Longitudinal column configurations shown in Appendix A, Figures A1 – A16

Table B.1 Cont. Comprehensive test results and data for No. 5 specimens with two hooks

	Hook	T_{max} lb	T_{ind} lb	T_{total} lb	T lb	T_h lb	T/T_h	$f_{su,max}$ psi	f_{su} psi	$f_{s,ACI}$ psi	Joint shear at failure/ $\sqrt{f_{cm}}$
1	A	14139	14029	28137	14069	16701	0.84	45609	45382	40122	3.6
	B	19575	14108					63147			
2	A	20758	17440	35627	17813	21824	0.82	66962	57463	53261	3.5
	B	18187	18187					58667			
3	B	23455	23455	23455	23455	28121	0.83	75663	75663	67650	1.8
4	A	19559	19559	38566	19283	15817	1.22	63094	62204	38116	4.4
	B	23982	19007					77362			
5	A	30340	30340	30340	30340	32611	0.93	97870	97870	78198	2.1
6	A	35211	28603	58973	29486	31727	0.93	113585	95117	71707	4.9
	B	30370	30370					97968			
7	A	32374	32374	32374	32374	38470	0.84	104432	104432	86440	2.2
8	A	40406	40351	60255	30128	32158	0.94	130342	97186	72994	4.3
	B	24657	19904					79538			
9	A	37404	34303	67166	33583	33080	1.02	120656	108333	77484	4.1
	B	32864	32864					106012			
10	A	26607	26607	52529	26265	23988	1.09	85831	84724	57119	4.1
	B	26095	25922					84176			
11	A	27578	27102	59140	29570	26839	1.10	88961	95387	70913	4.3
	B	32135	32038					103663			
12	A	21741	21741	44849	22425	25525	0.88	70131	72338	68744	2.8
	B	24995	23109					80630			
13	A	31878	31469	63347	31673	31209	1.01	102831	102172	82042	3.6
	B	35934	31878					115915			
14	A	23217	23089	44706	22353	21890	1.02	74893	72106	55975	4.9
	B	21747	21617					70152			
15	A	25504	25052	47902	23951	22384	1.07	82272	77261	57166	5.2
	B	24013	22850					77463			
16	A	40823	40823	83314	41657	45391	0.92	131688	134377	121728	3.6
	B	42491	42491					137066			
17	A	19389	19389	38441	19220	21121	0.91	62546	62001	60775	2.6
	B	23171	19051					74745			
18	A	36163	32648	65021	32511	28089	1.16	116656	104873	85295	3.7
	B	32373	32373					104430			
19	A	42470	42464	84441	42221	34712	1.22	137001	136196	104150	3.7
	B	41977	41977					135410			
20	A	43228	43228	83855	41927	36985	1.13	139446	135250	85935	4.5
	B	41140	40626					132710			
21	A	27197	27197	53033	26516	26284	1.01	87732	85537	62265	3.9
	B	25884	25836					83498			
22	A	25129	25129	50950	25475	25110	1.01	81060	82178	66825	3.2
	B	29054	25822					93723			
23	A	24440	24440	49083	24541	26783	0.92	78838	79166	72327	2.7
	B	27541	24643					88842			
24	A	39109	31179	65490	32745	34452	0.95	126159	105629	89581	3.2
	B	34311	34311					110679			
25	A	22045	22040	44241	22121	22672	0.98	71114	71357	63404	2.7
	B	23158	22201					74702			
26	A	46085	46016	90864	45432	44924	1.01	148661	146556	123859	3.3
	B	46076	44849					148631			

Table B.1 Cont. Comprehensive test results and data for No. 5 specimens with two hooks

	Hook	Slip at Failure in.	Failure Type	f_{yt} ksi	d_{tr} in.	$A_{tr,l}$ in. ²	N_{tr}	s_{tr} in.	A_{eti} in. ²	N_{eti}	s_{eti} in.	d_s in.	s_s in.	d_{cto} in.	N_{cto}	A_s in. ²	f_{ys} ksi
1	A B	- -	F/S F/S	60	-	-	-	-	0.88	4 ¹	2.5	0.375	2.50	-	-	1.27	60
2	A B	- -	F F/S	60	-	-	-	-	0.88	4 ¹	2.5	0.375	2.50	-	-	1.89	60
3	B	-	S	60	-	-	-	-	0.88	4 ¹	2.5	0.375	2.50	-	-	1.27	60
4	A B	- -	F/S F/S	60	-	-	-	-	0.88	4 ¹	2.5	0.375	2.50	-	-	1.27	60
5	A	-	S	60	-	-	-	-	0.88	4 ¹	2.5	0.375	2.50	-	-	1.27	60
6	A B	- -	F F/S	60	-	-	-	-	0.22	1 ¹	4.0	0.375	4.00	-	-	1.27	60
7	A	-	F/S	60	-	-	-	-	0.22	1 ¹	4.0	0.375	4.0	-	-	1.27	60
8	A B	- -	F F	60	-	-	-	-	0.22	1 ¹	4.0	0.375	4.00	-	-	1.89	60
9	A B	- -	F/S F/S	60	-	-	-	-	0.33	3	3.0	0.375	3.00	-	-	1.89	60
10	A B	- 0.192	F/S F/S	60	-	-	-	-	0.80	4	2.5	0.500	3.50	-	-	1.27	60
11	A B	- -	F/S S/F	60	-	-	-	-	0.80	4	4.0	0.500	4.00	-	-	1.27	60
12	A B	0.296 .330(.030)	F F	60	-	-	-	-	0.66	6	3.0	0.500	3.00	-	-	1.27	60
13	A B	- -	S/F S/F	60	-	-	-	-	0.80	4	4.0	0.500	4.00	-	-	1.27	60
14	A B	- -	F F	60	-	-	-	-	-	-	-	0.375	3.00	-	-	3.16	60
15	A B	- -	F/S F/S	60	-	-	-	-	-	-	-	0.375	3.00	-	-	3.16	60
16	A B	0.191 -	S F/S/TK	60	-	-	-	-	0.11	1	7.0	0.375	5.00	-	-	1.89	60
17	A B	- -	F/S F	60	-	-	-	-	0.66	6	2.5	0.500	3.00	-	-	1.27	60
18	A B	- -	F F	60	-	-	-	-	-	-	-	0.375	2.50	-	-	1.27	60
19	A B	- -	F *	60	-	-	-	-	-	-	-	0.375	3.50	-	-	3.16	60
20	A B	- -	S/F S/F	60	-	-	-	-	0.33	3	3.0	0.375	3.00	-	-	1.89	60
21	A B	- -	S F/S	60	-	-	-	-	0.80	4	2.5	0.375	3.50	-	-	1.27	60
22	A B	- -	F/S F/S	60	-	-	-	-	0.80	4	4.0	0.500	4.00	-	-	1.27	60
23	A B	0.152 .178(.150)	F/S F/S	60	-	-	-	-	0.66	6	3.0	0.500	3.00	-	-	1.27	60
24	A B	- -	F/S S	60	-	-	-	-	0.80	4	4.0	0.500	4.00	-	-	1.27	60
25	A B	- -	F F	60	-	-	-	-	0.66	6	2.5	0.500	3.00	-	-	1.27	60
26	A B	- -	BY BY	60	-	-	-	-	0.11	1	7.0	0.375	5.00	-	-	1.89	60

*Test terminated prior to failure of second hooked bar

¹Specimen had full stirrups around the longitudinal bars in the hook region but not around the hooked bars

Table B.1 Cont. Comprehensive test results and data for No. 5 specimens with two hooks

	Specimen	Hook	Bend Angle	Trans. Reinf. Orient.	Hook Bar Type	ℓ_{eh} in.	$\ell_{eh,avg}$ in.	f'_c psi	Age days	d_b in.
27	5-8-180-0-i-2.5-2-7	A B	180°	Para	A1035	7.4 7.1	7.3	9080	11	0.625
28	5-8-180-0-i-3.5-2-7	A B	180°	Para	A1035	7.4 7.3	7.3	9080	11	0.625
29	5-5-90-1#3-i-2.5-2-8	A B	90°	Para	A1035	8.0 7.6	7.8	5310	6	0.625
30	5-5-90-1#3-i-2.5-2-6	A B	90°	Para	A615	4.8 5.5	5.1	5800	9	0.625
31	5-8-90-1#3-i-2.5-2-6	A B	90°	Para	A615	6.0 6.3	6.1	8450	14	0.625
32	5-8-90-1#3-i-2.5-2-6(1)	A B	90°	Para	A1035	6.1 5.6	5.9	9300	13	0.625
33	5-8-90-1#3-i-3.5-2-6	A B	90°	Para	A1035	6.0 6.0	6.0	8710	16	0.625
34	5-8-90-1#3-i-3.5-2-6(1)	A B	90°	Para	A1035	6.3 6.3	6.3	9190	12	0.625
35	5-5-180-1#3-i-2.5-2-8	A B	180°	Para	A1035	8.0 7.8	7.9	5670	7	0.625
36	5-5-180-1#3-i-2.5-2-6	A B	180°	Para	A615	6.0 6.0	6.0	5800	9	0.625
37	5-8-180-1#3-i-2.5-2-7	A B	180°	Para	A1035	7.1 7.3	7.2	9300	13	0.625
38	5-8-180-1#3-i-3.5-2-7	A B	180°	Para	A1035	7.1 6.8	6.9	9190	12	0.625
39	5-5-90-1#4-i-2.5-2-8	A B	90°	Para	A1035	7.4 7.8	7.6	5310	6	0.625
40	5-5-90-1#4-i-2.5-2-6	A B	90°	Para	A615	5.3 5.8	5.5	5860	8	0.625
41	5-8-90-1#4-i-2.5-2-6	A B	90°	Para	A1035	5.9 6.0	6.0	9300	13	0.625
42	5-8-90-1#4-i-3.5-2-6	A B	90°	Para	A1035	6.0 7.0	6.5	9190	12	0.625
43	5-5-180-1#4-i-2.5-2-8	A B	180°	Para	A1035	8.0 8.0	8.0	5310	6	0.625
44	5-5-180-1#4-i-2.5-2-6	A B	180°	Para	A615	6.5 6.0	6.3	5670	7	0.625
45	5-5-180-2#3-o-1.5-2-11.25	A B	180°	Para	A1035	11.6 11.5	11.6	4420	7	0.625
46	5-5-180-2#3-o-1.5-2-9.5	B	180°	Para	A1035	8.8	8.8	4520	8	0.625
47	5-5-180-2#3-o-2.5-2-9.5	A B	180°	Para	A1035	9.1 9.3	9.2	4420	7	0.625
48	5-5-180-2#3-o-2.5-2-11.25	A B	180°	Para	A1035	11.1 11.4	11.3	4520	8	0.625
49	5-5-90-2#3-i-2.5-2-8	A B	90°	Para	A1035	8.0 7.5	7.8	5860	8	0.625
50	5-5-90-2#3-i-2.5-2-6	A B	90°	Para	A615	6.0 5.8	5.9	5800	9	0.625
51	5-8-90-2#3-i-2.5-2-6	A B	90°	Para	A1035	6.0 6.0	6.0	8580	15	0.625
52	5-8-90-2#3-i-2.5-2-8	A B	90°	Para	A1035	8.3 8.5	8.4	8380	13	0.625

Table B.1 Cont. Comprehensive test results and data for No. 5 specimens with two hooks

	Hook	R_r	b in.	h in.	h_{cl} in.	h_c in.	c_{so} in.	$c_{so,avg}$ in.	c_{th} in.	c_h in.	N_h	Axial Load kips	Long. Reinf. Layout ^o
27	A B	0.073	12.6	9.5	5.25	8.375	2.5 2.6	2.6	2.1 2.4	6.3	2	30	A1
28	A B	0.073	15.4	9.3	5.25	8.375	3.6 3.4	3.5	1.9 2.0	7.1	2	30	A1
29	A B	0.073	13.1	10.4	5.25	8.375	2.5 2.5	2.5	2.4 2.8	6.9	2	80	A1
30	A B	0.060	13.1	8.0	5.25	8.375	2.5 2.5	2.5	3.3 2.5	6.9	2	80	A1
31	A B	0.060	12.9	8.0	5.25	8.375	2.5 2.5	2.5	2.0 1.8	6.6	2	80	A1
32	A B	0.073	13.1	8.3	5.25	8.375	2.6 2.8	2.7	2.1 2.6	6.5	2	30	A1
33	A B	0.060	15.3	8.0	5.25	8.375	3.6 3.6	3.6	2.0 2.0	6.8	2	80	A1
34	A B	0.073	15.3	8.6	5.25	8.375	3.8 3.5	3.6	2.4 2.4	6.8	2	30	A1
35	A B	0.073	13.0	10.3	5.25	8.375	2.6 2.5	2.6	2.3 2.5	6.6	2	80	A1
36	A B	0.060	13.1	8.0	5.25	8.375	2.6 2.6	2.6	2.0 2.0	6.6	2	80	A1
37	A B	0.073	12.8	9.5	5.25	8.375	2.5 2.5	2.5	2.4 2.3	6.5	2	30	A1
38	A B	0.073	15.3	9.3	5.25	8.375	3.5 3.5	3.5	2.1 2.5	7.0	2	30	A1
39	A B	0.073	13.1	10.1	9.25	8.375	2.5 2.5	2.5	2.8 2.4	6.9	2	80	A1
40	A B	0.060	12.9	8.0	5.25	8.375	2.5 2.5	2.5	2.8 2.3	6.6	2	80	A1
41	A B	0.073	12.9	8.8	5.25	8.375	2.5 2.8	2.6	2.8 2.8	6.4	2	30	A1
42	A B	0.073	15.1	9.0	5.25	8.375	3.6 3.5	3.6	3.0 2.0	6.8	2	30	A1
43	A B	0.073	12.9	10.0	5.25	8.375	2.5 2.5	2.5	2.0 2.0	6.6	2	80	A1
44	A B	0.060	13.0	8.5	5.25	8.375	2.5 2.6	2.6	2.0 2.5	6.6	2	80	A1
45	A B	0.077	11.0	13.4	5.25	8.375	1.6 1.5	1.6	1.9 1.9	6.6	2	80	A4
46	B	0.08	12.0	11.0	5.25	8.375	1.6	1.6	2.4	6.6	2	80	A1
47	A B	0.077	12.9	11.3	5.25	8.375	2.5 2.5	2.5	2.1 2.0	6.6	2	80	A4
48	A B	0.077	13.1	13.6	5.25	8.375	2.5 2.8	2.6	2.5 2.1	6.6	2	80	A4
49	A B	0.073	12.9	10.0	5.38	8.375	2.5 2.5	2.5	2.0 2.5	6.6	2	80	A1
50	A B	0.060	13.1	8.5	5.25	8.375	2.6 2.6	2.6	2.5 2.8	6.6	2	80	A1
51	A B	0.073	13.0	8.0	5.25	8.375	2.8 2.9	2.8	2.0 2.0	6.1	2	80	A1
52	A B	0.073	12.9	10.0	5.25	8.375	2.6 2.5	2.6	1.8 1.5	6.5	2	80	A5

^o Longitudinal column configurations shown in Appendix A, Figures A1 – A16

Table B.1Cont. Comprehensive test results and data for No. 5 specimens with two hooks

	Hook	T_{max} lb	T_{ind} lb	T_{total} lb	T lb	T_h lb	T/T_h	$f_{su,max}$ psi	f_{su} psi	$f_{su,avg}$ psi	Joint shear at failure/ $\sqrt{f_{cm}}$
27	A B	26722 35215	26722 27495	54217	27108	29561	0.92	86199 113596	87446	78954	3.3
28	A B	34057 31441	30094 31414	61508	30754	29831	1.03	109860 101422	99206	79634	3.2
29	A B	32860 37440	32628 33645	66273	33136	31349	1.06	106001 120776	106892	65062	4.7
30	A B	20038 29285	19968 19863	39830	19915	21933	0.91	64639 94469	64242	44607	3.5
31	A B	26203 27858	26172 26974	53146	26573	28174	0.94	84524 89865	85719	64347	3.9
32	A B	29328 25430	29328 25430	54758	27379	27780	0.99	94606 82032	88319	64750	3.7
33	A B	41369 31173	28996 31173	60169	30084	27859	1.08	133448 100558	97046	63996	3.7
34	A B	28967 26270	25617 26194	51811	25905	29307	0.88	93441 84741	83565	68475	2.9
35	A B	36570 39949	36332 36565	72896	36448	32111	1.14	117967 128867	117575	67769	5.1
36	A B	29091 24285	23661 24171	47832	23916	25201	0.95	93843 78338	77148	52222	4.2
37	A B	34198 35367	34198 31621	65819	32909	33456	0.98	110316 114087	106159	79216	3.9
38	A B	35824 28925	35733 25266	60999	30500	32272	0.95	115563 93305	98386	76007	3.1
39	A B	35739 27537	27537 27537	55074	27537	33925	0.81	115288 88829	88829	62980	4.0
40	A B	21633 26769	21535 21379	42914	21457	26892	0.80	69782 86352	69217	48118	3.8
41	A B	23854 27932	23854 24731	48585	24292	31688	0.77	76947 90103	78363	65783	3.1
42	A B	25266 25221	25261 25221	50482	25241	33887	0.74	81504 81359	81423	71214	2.7
43	A B	43142 38421	38421 38421	76842	38421	35550	1.08	139167 123938	123938	66624	5.7
44	A B	25321 22912	23275 22679	45954	22977	29499	0.78	81681 73909	74119	53785	3.9
45	A B	48319 43017	43085 43017	86101	43051	43309	0.99	155868 138764	138873	87853	6.1
46	B	20282	20282	20282	20282	36939	0.61	65426	65426	67231	1.6
47	A B	35466 43930	35466 43930	79396	39698	34799	1.14	114406 141710	128058	69807	5.8
48	A B	43621 42484	42165 42484	84648	42324	42432	1.00	140714 137044	136530	86440	4.9
49	A B	37932 38949	37807 36500	74307	37154	31904	1.16	122360 125642	119850	67802	5.3
50	A B	31846 29191	29697 29191	58888	29444	24732	1.19	102730 94164	94980	51134	4.8
51	A B	33454 30874	30402 30874	61277	30638	27755	1.10	107916 99595	98833	63517	4.4
52	A B	39822 40545	39791 40545	80336	40168	37614	1.07	128457 130789	129574	87619	4.8

Table B.1 Cont. Comprehensive test results and data for No. 5 specimens with two hooks

	Hook	Slip at Failure in.	Failure Type	f_{yt} ksi	d_{tr} in.	$A_{tr,l}$ in. ²	N_{tr}	s_{tr} in.	A_{cti} in. ²	N_{cti}	s_{cti} in.	d_s in.	s_s in.	d_{cto} in.	N_{cto}	A_s in. ²	f_{ys} ksi
27	A	0.194	F/S	60	-	-	-	-	0.22	2	4.0	0.500	3.00	-	-	1.27	60
	B	.146(.016)	S/F														
28	A	0.251	S/F	60	-	-	-	-	0.22	2	4.0	0.500	3.00	-	-	1.27	60
	B	.237(.021)	F/S														
29	A	-	F	60	0.38	0.11	1	5.00	0.44	4	6.0	0.375	4.00	-	-	1.27	60
	B	-	S/F														
30	A	-	S	60	0.38	0.11	1	5.00	0.44	4	6.0	0.375	4.00	-	-	1.27	60
	B	-	S/F														
31	A	-	F	60	0.38	0.11	1	5.00	0.80	4	6.0	0.500	4.00	-	-	1.27	60
	B	-	S														
32	A	-	F/S	60	0.38	0.11	1	6.00	0.66	6	3.0	0.500	3.00	-	-	1.27	60
	B	-	F/S														
33	A	-	F/S	60	0.38	0.11	1	5.00	0.80	4	6.0	0.500	4.00	-	-	1.27	60
	B	-	F/S														
34	A	0.239	F/S	60	0.38	0.11	1	6.00	0.66	6	3.0	0.500	3.00	-	-	1.27	60
	B	0.158	F/S														
35	A	-	S	60	0.38	0.11	1	4.00	-	-	-	0.375	4.00	-	-	1.27	60
	B	-	S/F														
36	A	-	S/F	60	0.38	0.11	1	4.00	-	-	-	0.375	4.00	-	-	1.27	60
	B	-	F/S														
37	A	0.373	F/S	60	0.38	0.11	1	3.00	-	-	-	0.375	3.00	-	-	1.27	60
	B	.261(.035)	F/S														
38	A	0.205	F	60	0.38	0.11	1	3.00	-	-	-	0.375	3.00	-	-	1.27	60
	B	0.238	F														
39	A	-	F/S	60	0.5	0.20	1	5.00	0.44	4	6.0	0.375	4.00	-	-	1.27	60
	B	-	S														
40	A	-	S	60	0.5	0.20	1	5.00	0.44	4	6.0	0.375	4.00	-	-	1.27	60
	B	-	S														
41	A	0.25	F	60	0.5	0.20	1	6.00	0.44	4	6.0	0.500	3.00	-	-	1.27	60
	B	0.22	F/S														
42	A	-	F/S	60	0.5	0.20	1	6.00	0.44	4	6.0	0.500	3.00	-	-	1.27	60
	B	-	F/S														
43	A	-	F/S	60	0.5	0.20	1	4.00	-	-	-	0.375	4.00	-	-	1.27	60
	B	-	F														
44	A	-	F/S	60	0.5	0.20	1	4.00	-	-	-	0.375	4.00	-	-	1.27	60
	B	-	F														
45	A	-	F/S	60	0.38	0.11	2	2.00	-	-	-	0.375	4.00	-	-	1.89	60
	B	-	F/S														
46	B	-	F/S	60	0.375	0.11	2	2.0	-	-	-	0.375	4.0	-	-	1.27	60
47	A	-	F/S	60	0.38	0.11	2	2.00	-	-	-	0.375	4.00	-	-	1.89	60
	B	-	F														
48	A	-	F	60	0.38	0.11	2	2.00	-	-	-	0.375	4.50	-	-	1.89	60
	B	-	F/S														
49	A	-	S/F	60	0.38	0.11	2	4.00	-	-	-	0.375	4.00	-	-	1.27	60
	B	-	S/F														
50	A	-	F/S	60	0.38	0.11	2	4.00	-	-	-	0.375	4.00	-	-	1.27	60
	B	-	F/S														
51	A	-	F/S	60	0.38	0.11	2	4.00	-	-	-	0.500	4.00	-	-	1.27	60
	B	-	F/S														
52	A	-	F/S	60	0.38	0.11	2	4.00	-	-	-	0.500	4.00	-	-	1.67	60
	B	-	F/S														

Table B.1 Cont. Comprehensive test results and data for No. 5 specimens with two hooks

	Specimen	Hook	Bend Angle	Trans. Reinf. Orient.	Hook Bar Type	ℓ_{eh} in.	$\ell_{eh,avg}$ in.	f'_c psi	Age days	d_b in.
53	5-12-90-2#3-i-2.5-2-5	A B	90°	Para	A1035	5.8 5.8	5.8	11090	83	0.625
54	5-15-90-2#3-i-2.5-2-6	A B	90°	Para	A1035	6.3 6.5	6.4	15800	61	0.625
55	5-15-90-2#3-i-2.5-2-4	A B	90°	Para	A1035	3.5 4.0	3.8	15800	61	0.625
56	5-5-90-2#3-i-3.5-2-6	A B	90°	Para	A1035	6.0 5.8	5.9	5230	6	0.625
57	5-5-90-2#3-i-3.5-2-8	A B	90°	Para	A1035	7.9 7.5	7.7	5190	7	0.625
58	5-8-90-2#3-i-3.5-2-6	A B	90°	Para	A1035	6.5 6.0	6.3	8580	15	0.625
59	5-8-90-2#3-i-3.5-2-8	A B	90°	Para	A1035	7.1 7.0	7.1	8710	16	0.625
60	5-12-90-2#3-i-3.5-2-5	A B	90°	Para	A1035	5.6 5.3	5.4	10410	15	0.625
61	5-12-90-2#3-i-3.5-2-10	A B	90°	Para	A1035	10.8 10.6	10.7	11090	83	0.625
62	5-5-180-2#3-i-2.5-2-8	A B	180°	Para	A1035	8.0 8.0	8.0	5670	7	0.625
63	5-5-180-2#3-i-2.5-2-6	A B	180°	Para	A615	5.8 5.5	5.6	5860	8	0.625
64	5-8-180-2#3-i-2.5-2-7	A B	180°	Para	A1035	7.0 7.3	7.1	9080	11	0.625
65	5-8-180-2#3-i-3.5-2-7	A B	180°	Para	A1035	6.8 6.9	6.8	9080	11	0.625
66	5-8-90-4#3-i-2.5-2-8	A B	90°	Para	A1035	7.9 7.5	7.7	8380	13	0.625
67	5-8-90-4#3-i-3.5-2-8	A B	90°	Para	A1035	8.6 8.3	8.4	8380	13	0.625
68	5-5-90-5#3-o-1.5-2-5	B	90°	Para	A615	5.0	5.0	5205	5	0.625
69	5-5-90-5#3-o-1.5-2-8	A B	90°	Para	A1035	8.0 7.8	7.9	5650	6	0.625
70	5-5-90-5#3-o-1.5-2-6.5	A B	90°	Para	A1035	6.5 6.5	6.5	5780	7	0.625
71	5-5-90-5#3-o-2.5-2-5	A B	90°	Para	A615	5.2 5.1	5.2	4903	4	0.625
72	5-5-90-5#3-o-2.5-2-8	A	90°	Para	A1035	7.5	7.5	5650	6	0.625
73	5-5-90-5#3-i-2.5-2-7	A B	90°	Para	A1035	5.6 7.0	6.3	5230	6	0.625
74	5-12-90-5#3-i-2.5-2-5	A B	90°	Para	A1035	5.1 5.8	5.4	10410	15	0.625
75	5-15-90-5#3-i-2.5-2-4	A B	90°	Para	A1035	3.8 4.1	4.0	15800	62	0.625
76	5-15-90-5#3-i-2.5-2-5	A B	90°	Para	A1035	5.0 5.1	5.1	15800	62	0.625
77	5-5-90-5#3-i-3.5-2-7	A B	90°	Para	A1035	7.5 6.8	7.1	5190	7	0.625
78	5-12-90-5#3-i-3.5-2-5	A B	90°	Para	A1035	5.3 4.8	5.0	11090	83	0.625
79	5-12-90-5#3-i-3.5-2-10	A B	90°	Para	A1035	11.0 11.3	11.1	11090	83	0.625

Table B.1 Cont. Comprehensive test results and data for No. 5 specimens with two hooks

	Hook	R_r	b in.	h in.	h_{cl} in.	h_c in.	c_{so} in.	$c_{so,avg}$ in.	c_{th} in.	c_h in.	N_h	Axial Load kips	Long. Reinf. Layout ^o
53	A B	0.073	13.0	8.8	5.25	8.375	2.5 2.8	2.6	3.0 3.0	6.5	2	30	A1
54	A B	0.073	12.6	8.2	5.25	8.375	2.4 2.4	2.4	1.9 1.7	6.6	2	30	A2
55	A B	0.073	13.0	6.1	5.25	8.375	2.5 2.5	2.5	2.6 2.1	6.8	2	30	A9
56	A B	0.073	14.5	8.3	5.25	8.375	3.4 3.4	3.4	2.3 2.5	6.5	2	30	A1
57	A B	0.073	14.9	10.3	5.25	8.375	3.4 3.5	3.4	2.3 2.8	6.8	2	30	A1
58	A B	0.073	14.9	8.0	5.25	8.375	3.5 3.8	3.6	1.5 2.0	6.4	2	80	A1
59	A B	0.060	14.9	10.0	5.25	8.375	3.5 3.5	3.5	2.9 3.0	6.6	2	80	A5
60	A B	0.073	15.1	7.4	5.25	8.375	3.8 3.5	3.6	1.8 2.2	6.6	2	30	A1
61	A B	0.073	15.1	13.0	5.25	8.375	3.5 3.6	3.6	2.3 2.4	6.8	2	30	A4
62	A B	0.073	13.1	10.0	5.25	8.375	2.5 2.5	2.5	2.0 2.0	6.9	2	80	A1
63	A B	0.060	13.1	7.8	5.25	8.375	2.6 2.6	2.6	2.0 2.3	6.6	2	80	A1
64	A B	0.073	12.6	9.3	5.25	8.375	2.5 2.5	2.5	2.3 2.1	6.4	2	30	A1
65	A B	0.073	15.1	9.2	5.25	8.375	3.4 3.5	3.4	2.4 2.3	7.0	2	30	A1
66	A B	0.060	12.6	10.0	5.25	8.375	2.5 2.5	2.5	2.1 2.5	6.4	2	80	A5
67	A B	0.060	15.1	10.0	5.25	8.375	3.5 3.5	3.5	1.4 1.8	6.9	2	80	A5
68	B	0.077	10.8	7.1	5.25	8.375	1.5	1.5	2.0	6.5	2	80	A1
69	A B	0.077	10.7	10.3	5.25	8.375	1.6 1.5	1.5	2.3 2.6	6.4	2	80	A1
70	A B	0.073	10.9	8.5	5.25	8.375	1.6 1.6	1.6	2.0 2.0	6.5	2	80	A4
71	A B	0.077	13.1	7.0	5.38	8.375	2.6 2.6	2.6	1.9 1.9	6.6	2	80	A1
72	A	0.077	13.1	10.4	5.25	8.375	2.6	2.6	2.1	6.5	2	80	A1
73	A B	0.073	13.3	9.3	5.25	8.375	2.8 2.8	2.8	3.6 2.3	6.5	2	30	A1
74	A B	0.073	13.0	7.3	5.25	8.375	2.6 2.6	2.6	2.1 1.5	6.5	2	30	A1
75	A B	0.073	12.8	6.0	5.25	8.375	2.4 2.5	2.4	2.2 1.9	6.6	2	30	A9
76	A B	0.073	12.8	7.1	5.25	8.375	2.4 2.3	2.4	2.1 1.9	6.8	2	30	A2
77	A B	0.073	15.1	9.5	5.25	8.375	3.4 3.5	3.4	2.0 2.8	7.0	2	30	A1
78	A B	0.073	14.4	7.0	5.25	8.375	3.3 3.3	3.3	2.5 1.5	6.6	2	30	A1
79	A B	0.073	15.1	13.0	5.25	8.375	3.5 3.5	3.5	2.0 1.8	6.9	2	30	A4

^o Longitudinal column configurations shown in Appendix A, Figures A1 – A16

Table B.1 Cont. Comprehensive test results and data for No. 5 specimens with two hooks

	Hook	T_{max} lb	T_{ind} lb	T_{total} lb	T lb	T_h lb	T/T_h	$f_{su,max}$ psi	f_{su} psi	$f_{su,avg}$ psi	Joint shear at failure/ $\sqrt{f_{cm}}$
53	A	25201	25120	48696	24348	28463	0.86	81295	78542	69203	2.8
	B	29393	23576					94816			
54	A	42381	42381	85276	42638	34250	1.24	136714	137542	91580	4.6
	B	42895	42895					138371			
55	A	18652	18652	37334	18667	21220	0.88	60167	60217	53871	2.6
	B	21256	18683					68569			
56	A	21341	21146	42186	21093	24118	0.87	68842	68042	48557	3.4
	B	21262	21040					68586			
57	A	43675	43675	89329	44665	30822	1.45	140887	144079	63551	5.7
	B	45654	45654					147271			
58	A	29930	29930	60069	30035	28807	1.04	96549	96886	66163	3.8
	B	30139	30139					97223			
59	A	38022	28716	57312	28656	32368	0.89	122652	92439	75329	2.9
	B	28596	28596					92246			
60	A	27860	27860	56728	28364	26634	1.06	89871	91497	63404	3.4
	B	28869	28869					93124			
61	A	46561	44490	90490	45245	51228	0.88	150197	145952	128628	3.1
	B	46006	46001					148406			
62	A	34036	33674	68157	34078	36883	0.92	109795	109930	68845	4.8
	B	34483	34483					111236			
63	A	26852	26782	53456	26728	28154	0.95	86620	86220	49211	4.8
	B	26912	26674					86814			
64	A	34580	29762	58459	29230	37280	0.78	111548	94289	77592	3.6
	B	28697	28697					92572			
65	A	29310	29285	61862	30931	35933	0.86	94550	99777	74189	3.3
	B	32577	32577					105086			
66	A	33367	25867	52823	26411	38991	0.68	107636	85198	80426	3.2
	B	27016	26955					87150			
67	A	42471	37810	76960	38480	42178	0.91	137003	124130	88273	3.9
	B	39278	39150					126704			
68	B	22060	22060	22060	22060	25225	0.74	71000	71000	51500	2.8
69	A	25173	25173	50221	25110	40815	0.62	81202	81002	84562	4.2
	B	30446	25048					98211			
70	A	26229	22736	43422	21711	35791	0.61	84610	70035	70596	4.3
	B	20940	20686					67550			
71	A	22279	22230	45058	22529	29921	0.75	71868	72675	51578	4.9
	B	29466	22829					95050			
72	A	28429	28429	28429	28429	39398	0.72	91706	91706	80536	1.9
73	A	32080	32080	63393	31696	34446	0.92	103484	102246	65216	5.0
	B	31340	31313					101095			
74	A	33923	33923	68839	34420	35366	0.97	109428	111031	79255	5.0
	B	34916	34916					112634			
75	A	31312	31312	62637	31318	31021	1.01	101006	101027	71266	4.5
	B	31325	31325					101048			
76	A	38574	38574	78312	39156	36416	1.08	124434	126309	90907	4.8
	B	46165	39737					148921			
77	A	44301	36844	72050	36025	37369	0.96	142906	116210	73328	4.9
	B	35206	35206					113568			
78	A	31472	31396	60882	30441	33822	0.90	101522	98196	75221	4.0
	B	31302	29485					100973			
79	A	46464	46464	92102	46051	62014	0.74	149882	148551	167366	3.1
	B	45703	45638					147430			

Table B.1 Cont. Comprehensive test results and data for No. 5 specimens with two hooks

	Hook	Slip at Failure in.	Failure Type	f_{yt} ksi	d_{tr} in.	$A_{tr,l}$ in. ²	N_{tr}	s_{tr} in.	A_{cti} in. ²	N_{cti}	s_{cti} in.	d_s in.	s_s in.	d_{cto} in.	N_{cto}	A_s in. ²	f_{ys} ksi
53	A B	- -	F/S F	60	0.38	0.11	2	3.30	0.33	3	3.3	0.500	3.00	-	-	1.27	60
54	A B	- -	F F	60	0.38	0.11	2	3.00	-	-	-	0.375	2.75	-	-	3.16	60
55	A B	- -	F F	60	0.38	0.11	2	3.00	-	-	-	0.375	1.75	-	-	2.51	60
56	A B	0.183 -	S/F S/F	60	0.38	0.11	2	3.50	0.11	1	3.5	0.375	3.50	-	-	1.27	60
57	A B	- -	F F	60	0.38	0.11	2	3.50	-	-	-	0.375	4.00	-	-	1.27	60
58	A B	- -	F F/S	60	0.38	0.11	2	4.00	-	-	-	0.500	4.00	-	-	1.27	60
59	A B	- -	F F	60	0.38	0.11	2	4.00	-	-	-	0.500	4.00	-	-	1.67	60
60	A B	- 0.349	F F	60	0.38	0.11	2	3.33	0.33	3	3.3	0.500	3.00	-	-	1.27	60
61	A B	- -	BY BY	60	0.38	0.11	2	3.30	-	-	-	0.375	5.00	-	-	1.89	60
62	A B	- -	F/S F/S	60	0.38	0.11	2	2.50	-	-	-	0.375	4.00	-	-	1.27	60
63	A B	- -	F/S F	60	0.38	0.11	2	2.50	-	-	-	0.375	4.00	-	-	1.27	60
64	A B	- .369(.081)	F/S F/S	60	0.38	0.11	2	2.00	-	-	-	0.375	3.00	-	-	1.27	60
65	A B	- .329(.028)	F/S F	60	0.38	0.11	2	2.00	-	-	-	0.375	3.00	-	-	1.27	60
66	A B	- -	F/S F/S	60	0.38	0.11	4	2.00	-	-	-	0.500	4.00	-	-	1.67	60
67	A B	- -	F S/F	60	0.38	0.11	4	2.00	-	-	-	0.500	4.00	-	-	1.67	60
68	B	-	F/S	60	0.375	0.11	5	2.00	-	-	-	0.375	2.50	-	-	1.27	60
69	A B	- -	F/S F/S	60	0.38	0.11	5	2.50	-	-	-	0.375	2.50	-	-	1.27	60
70	A B	- -	F/S F/S	60	0.38	0.11	5	2.50	-	-	-	0.375	2.50	-	-	1.89	60
71	A B	- -	F/S F/S	60	0.38	0.11	5	2.00	-	-	-	0.375	2.50	-	-	1.27	60
72	A	-	F	60	0.375	0.11	5	2.50	-	-	-	0.375	2.50	-	-	1.27	60
73	A B	- -	F F/S	60	0.38	0.11	5	1.75	-	-	-	0.500	3.50	-	-	1.27	60
74	A B	0.292 0.295	F/S S/F	60	0.38	0.11	5	1.67	-	-	-	0.500	3.00	-	-	1.27	60
75	A B	0.603 0.378	F F	60	0.38	0.11	5	1.75	-	-	-	0.375	1.75	-	-	2.51	60
76	A B	- -	F BY	60	0.38	0.11	5	1.75	-	-	-	0.375	2.25	-	-	3.16	60
77	A B	- -	F F	60	0.38	0.11	5	1.75	-	-	-	0.500	3.50	-	-	1.27	60
78	A B	- -	F F	60	0.38	0.11	5	1.70	-	-	-	0.500	3.00	-	-	1.27	60
79	A B	- -	BY BY	60	0.38	0.11	5	1.70	-	-	-	0.375	5.00	-	-	1.89	60

Table B.2 Comprehensive test results and data for No. 8 specimens with two hooks

	Specimen	Hook	Bend Angle	Trans. Reinf. Orient.	Hook Bar Type	ℓ_{ch} in.	$\ell_{ch,avg}$ in.	f'_c psi	Age days	d_b in.
80	8-5-90-0-o-2.5-2-10a	A B	90°	Para	A1035 ^a	10.3 10.5	10.4	5270	7	1
81	8-5-90-0-o-2.5-2-10b	A B	90°	Para	A1035 ^a	9.3 10.3	9.8	5440	8	1
82	8-5-90-0-o-2.5-2-10c	A B	90°	Para	A1035 ^a	10.8 10.5	10.6	5650	9	1
83	8-8-90-0-o-2.5-2-8	A B	90°	Para	A1035 ^b	8.6 8.3	8.4	8740	12	1
84	8-8-90-0-o-3.5-2-8	A B	90°	Para	A1035 ^b	7.6 8.0	7.8	8810	14	1
85	8-8-90-0-o-4-2-8	A B	90°	Para	A1035 ^b	8.1 8.3	8.2	8630	11	1
86	8-5-90-0-i-2.5-2-16	A B	90°	Para	A1035 ^b	16.0 16.8	16.4	4980	7	1
87	8-5-90-0-i-2.5-2-9.5	A B	90°	Para	A615	9.0 10.3	9.6	5140	8	1
88	8-5-90-0-i-2.5-2-12.5	A B	90°	Para	A615	13.3 13.3	13.3	5240	9	1
89	8-5-90-0-i-2.5-2-18	A B	90°	Para	A1035 ^b	19.5 17.9	18.7	5380	11	1
90	8-5-90-0-i-2.5-2-13	A B	90°	Para	A1035 ^b	13.3 13.5	13.4	5560	11	1
91	8-5-90-0-i-2.5-2-15(1)	A B	90°	Para	A1035 ^b	14.5 15.3	14.9	5910	14	1
92	8-5-90-0-i-2.5-2-15	A B	90°	Para	A1035 ^b	15.3 14.4	14.8	6210	8	1
93	(2@3) 8-5-90-0-i-2.5-2-10*	A B	90°	Para	A615	10.4 10.6	10.5	4490	10	1
94	(2@5) 8-5-90-0-i-2.5-2-10*	A B	90°	Para	A615	10.1 10.1	10.1	4490	10	1
95	8-8-90-0-i-2.5-2-8	A B	90°	Para	A1035 ^b	8.9 8.0	8.4	7910	15	1
96	8-8-90-0-i-2.5-2-10	A B	90°	Para	A1035 ^b	9.8 9.5	9.6	7700	14	1
97	8-8-90-0-i-2.5-2-8(1)	A B	90°	Para	A1035 ^b	8.0 8.0	8.0	8780	13	1
98	8-8-90-0-i-2.5sc-2tc-9*	A B	90°	Para	A615	9.5 9.5	9.5	7710	25	1
99	8-8-90-0-i-2.5sc-9tc-9	A B	90°	Para	A615	9.3 9.0	9.1	7710	25	1
100	(2@3) 8-8-90-0-i-2.5-9-9	A B	90°	Para	A615	9.3 9.0	9.1	7510	21	1
101	(2@4) 8-8-90-0-i-2.5-9-9	A B	90°	Para	A615	9.9 10.0	9.9	7510	21	1
102	8-12-90-0-i-2.5-2-9	A B	90°	Para	A1035 ^b	9.0 9.0	9.0	11160	77	1
103	8-12-90-0-i-2.5-2-12.5	A B	90°	Para	A1035 ^c	12.9 12.8	12.8	11850	39	1
104	8-12-90-0-i-2.5-2-12	A B	90°	Para	A1035 ^c	12.1 12.1	12.1	11760	34	1
105	8-15-90-0-i-2.5-2-8.5	A B	90°	Para	A1035 ^c	8.8 8.9	8.8	15800	61	1

* Specimen contained A1035 Grade 120 for column longitudinal steel

^a Heat 1, ^b Heat 2, ^c Heat 3 as described in Table 2.3

Table B.2 Cont. Comprehensive test results and data for No. 8 specimens with two hooks

	Hook	R_r	b in.	h in.	h_{cl} in.	h_c in.	c_{so} in.	$c_{so,avg}$ in.	c_{th} in.	c_h in.	N_h	Axial Load kips	Long. Reinf. Layout ^o
80	A B	0.084	17.1	12.3	10.5	8.375	2.5 2.6	2.6	2.0 1.8	10.0	2	80	A2
81	A B	0.084	17.0	12.5	10.5	8.375	2.5 2.5	2.5	3.3 2.3	10.0	2	80	A2
82	A B	0.084	17.0	12.3	10.5	8.375	2.5 2.5	2.5	1.5 1.8	10.0	2	80	A2
83	A B	0.078	16.3	10.4	10.5	8.375	2.8 2.5	2.6	1.8 2.1	9.0	2	30	A2
84	A B	0.078	18.9	10.0	10.5	8.375	3.5 3.6	3.6	2.4 2.0	9.8	2	30	A2
85	A B	0.078	20.0	10.6	10.5	8.375	4.5 3.8	4.1	2.5 2.4	9.8	2	30	A2
86	A B	0.078	17.0	17.9	10.5	8.375	2.8 2.8	2.8	1.8 1.4	9.5	2	80	A2
87	A B	0.078	16.8	12.0	10.5	8.375	2.8 2.5	2.6	3.0 1.8	9.5	2	80	A2
88	A B	0.078	17.3	14.5	10.5	8.375	2.8 2.8	2.8	1.3 1.3	9.8	2	80	A2
89	A B	0.078	17.5	20.3	10.5	8.375	2.5 2.5	2.5	0.8 2.4	10.5	2	30	A6
90	A B	0.078	16.8	15.3	10.5	8.375	2.5 2.5	2.5	2.0 1.8	9.8	2	30	A2
91	A B	0.073	16.7	17.3	10.5	8.375	2.5 2.6	2.5	2.8 2.0	9.6	2	30	A2
92	A B	0.073	16.6	17.3	10.5	8.375	2.5 2.6	2.6	2.0 2.9	9.5	2	30	A2
93	A B	0.073	9.0	12.0	10.5	8.375	2.5 2.5	2.5	1.6 1.4	2.0	2	30	A2
94	A B	0.073	10.9	12.0	10.5	8.375	2.5 2.3	2.4	1.9 1.9	4.1	2	30	A2
95	A B	0.078	16.3	10.0	10.5	8.375	2.8 2.9	2.8	1.1 2.0	8.6	2	30	A2
96	A B	0.078	16.6	12.0	10.5	8.375	2.8 2.9	2.8	2.3 2.5	9.0	2	30	A2
97	A B	0.078	17.0	10.8	10.5	8.375	2.8 2.8	2.8	2.8 2.8	9.5	2	30	A2
98	A B	0.073	17.3	11.0	10.5	8.375	2.5 2.8	2.6	1.5 1.5	10.0	2	30	A2
99	A B	0.073	17.5	18.0	10.5	8.375	2.8 2.8	2.8	8.8 9.0	10.0	2	30	A7
100	A B	0.073	9.1	18.0	10.5	8.375	2.5 2.6	2.6	8.8 9.0	2.0	2	30	A7
101	A B	0.073	10.2	18.0	10.5	8.375	2.6 2.5	2.5	8.1 8.0	3.1	2	30	A7
102	A B	0.078	17.0	11.4	10.5	8.375	2.8 2.6	2.7	2.4 2.4	9.6	2	30	A2
103	A B	0.073	17.4	14.6	10.5	8.375	2.6 2.6	2.6	1.7 1.8	10.1	2	30	A2
104	A B	0.073	16.8	14.0	10.5	8.375	2.5 2.4	2.5	1.9 1.9	9.8	2	30	A2
105	A B	0.073	17.0	10.8	10.5	8.375	2.5 2.5	2.5	2.0 1.9	10.0	2	30	A6

^o Longitudinal column configurations shown in Appendix A, Figures A1 – A16

Table B.2 Cont. Comprehensive test results and data for No. 8 specimens with two hooks

	Hook	T_{max} lb	T_{ind} lb	T_{total} lb	T lb	T_h lb	T/T_h	$f_{su,max}$ psi	f_{su} psi	$f_{s,ACI}$ psi	Joint shear at failure/ $\sqrt{f_{cm}}$
80	A	40645	38970	84628	42314	47578	0.89	51449	53562	53798	3.4
	B	46612	45658					59003			
81	A	47870	38190	67302	33651	44958	0.75	60596	42596	51366	2.6
	B	30599	29112					38733			
82	A	62682	57437	111949	55975	49790	1.12	79345	70854	57046	4.3
	B	54558	54512					69061			
83	A	44396	32792	66029	33015	44255	0.75	56198	41791	56343	2.5
	B	33238	33238					42073			
84	A	35613	35613	71745	35872	40883	0.88	45080	45408	52378	2.5
	B	44488	36132					56314			
85	A	37130	35849	75022	37511	42709	0.88	47000	47482	54329	2.3
	B	39173	39173					49586			
86	A	83310	83310	166479	83239	75922	1.10	105455	105366	82541	4.7
	B	86063	83169					108940			
87	A	44627	44627	88971	44485	43624	1.02	56489	56311	49289	3.7
	B	65800	44344					83291			
88	A	65254	65254	131639	65819	61559	1.07	82600	83316	68510	4.4
	B	69872	66385					88446			
89	A	100169	82023	161763	80881	89312	0.91	126796	102381	97907	3.8
	B	79805	79740					101018			
90	A	73143	65881	131078	65539	63253	1.04	92586	82960	71237	4.2
	B	65197	65197					82527			
91	A	64532	64532	127534	63767	72061	0.88	81686	80718	81681	3.5
	B	87275	63002					110475			
92	A	76256	76162	150955	75478	72778	1.04	96527	95541	83377	4.0
	B	80724	74793					102182			
93	A	38900	38908	80626	40313	45999	0.88	49241	51029	50256	6.8
	B	41700	41718					52785			
94	A	41853	41853	80104	40052	43959	0.91	52979	50699	48150	5.5
	B	38251	38251					48419			
95	A	54674	45317	90486	45243	42993	1.05	69208	57269	53601	3.8
	B	45169	45169					57176			
96	A	50000	49985	102911	51455	49048	1.05	63291	65134	60328	3.6
	B	52926	52926					66995			
97	A	38047	35988	73642	36821	41882	0.88	48161	46609	53544	2.6
	B	37660	37654					47671			
98	A	35543	35543	70199	35100	48392	0.73	44991	44430	59583	2.6
	B	34656	34656					43868			
99	A	38519	38519	75358	37679	46369	0.81	48758	47695	57231	1.7
	B	36839	36839					46632			
100	A	34015	33826	61345	30672	46017	0.67	43057	38826	56484	2.6
	B	27575	27518					34905			
101	A	32856	32856	68391	34195	50372	0.68	41590	43285	61513	2.6
	B	35534	35534					44980			
102	A	50809	50677	99845	49923	50870	0.98	64315	63193	67912	3.0
	B	54796	49168					69362			
103	A	66009	65995	133873	66937	75268	0.89	83555	84730	99624	2.9
	B	77378	67878					97947			
104	A	70689	65980	131758	65879	70837	0.93	89479	83391	93920	3.1
	B	65778	65778					83263			
105	A	43063	43063	87150	43575	55024	0.79	54510	55158	79122	2.3
	B	44087	44087					55807			

Table B.2 Cont. Comprehensive test results and data for No. 8 specimens with two hooks

	Hook	Slip at Failure in.	Failure Type	f_{yt} ksi	d_{tr} in.	$A_{tr,t}$ in. ²	N_{tr}	S_{tr} in.	A_{cti} in. ²	N_{cti}	S_{cti} in.	d_s in.	s_s in.	d_{cto} in.	N_{cto}	A_s in. ²	f_{ys} ksi
80	A B	- 0.186	F/S S/F	60	-	-	-	-	3.10	5	3.5	0.63	3.50	-	-	3.16	60
81	A B	- -	F/S S/F	60	-	-	-	-	3.10	5	3.5	0.63	3.50	-	-	3.16	60
82	A B	- 0.132	F/S S/F/TK	60	-	-	-	-	3.10	5	3.5	0.63	3.50	-	-	3.16	60
83	A B	0.153 0.113	S/TK S/TK	60	-	-	-	-	2.00	10	3.0	0.50	1.75	-	-	3.16	60
84	A B	- -	F/S S/F	60	-	-	-	-	2.00	10	3.0	0.50	1.75	-	-	3.16	60
85	A B	0.362 (.0017)	S/F S	60	-	-	-	-	2.00	10	3.0	0.50	1.75	-	-	3.16	60
86	A B	- -	F/S F/TK	60	-	-	-	-	2.00	10	3.0	0.50	3.00	-	-	3.16	60
87	A B	- -	F S	60	-	-	-	-	2.00	10	3.0	0.50	3.00	-	-	3.16	60
88	A B	- -	S/F S	60	-	-	-	-	2.00	10	3.0	0.50	3.00	-	-	3.16	60
89	A B	- 0.153	F/S/TK F/S/TK	60	-	-	-	-	1.10	10	3.0	0.38	3.50	0.375	1	3.78	60
90	A B	- -	S F/S	60	-	-	-	-	1.00	5	3.0	0.50	3.00	0.375	1	3.16	60
91	A B	- -	F/S S	60	-	-	-	-	1.10	10	3.0	0.38	3.50	0.375	2	3.16	60
92	A B	- -	S/F S/F	60	-	-	-	-	1.10	10	3.0	0.38	3.50	0.375	2	3.16	60
93	A B	0.2 -	F F	60	-	-	-	-	-	-	-	0.38	5.00	-	-	3.16	120
94	A B	0.33 0	F F/S	60	-	-	-	-	-	-	-	0.38	5.00	-	-	3.16	120
95	A B	- -	F/TK F/S	60	-	-	-	-	1.60	8	4.0	0.50	1.75	-	-	3.16	60
96	A B	0.195 0.185	F F	60	-	-	-	-	1.60	8	4.0	0.63	3.50	-	-	3.16	60
97	A B	0.387 0.229	F/S F/S	60	-	-	-	-	1.60	8	4.0	0.50	1.50	-	-	3.16	60
98	A B	0.104 0	F F	60	-	-	-	-	-	-	-	0.38	4.00	-	-	3.16	60
99	A B	0.12 0.29	F F	60	-	-	-	-	-	-	-	0.38	4.00	-	-	4.74	60
100	A B	- -	F F	60	-	-	-	-	-	-	-	0.38	4.00	-	-	4.74	60
101	A B	0.018 0	F F	60	-	-	-	-	-	-	-	0.38	4.00	-	-	4.74	60
102	A B	0.219	F/S S/F	60	-	-	-	-	0.88	8	4.0	0.50	4.00	0.375	2	3.16	60
103	A B	0.295 0.266	F/S F/S	60	-	-	-	-	-	-	-	0.50	2.25	-	-	3.16	60
104	A B	- 0.0119	S/F F/S	60	-	-	-	-	-	-	-	0.38	4.00	-	-	3.16	60
105	A B	- -	F F	60	-	-	-	-	-	-	-	0.38	4.00	-	-	3.78	60

Table B.2 Cont. Comprehensive test results and data for No. 8 specimens with two hooks

	Specimen	Hook	Bend Angle	Trans. Reinf. Orient.	Hook Bar Type	l_{eh} in.	$l_{eh,avg}$ in.	f'_c psi	Age days	d_b in.
106	8-15-90-0-i-2.5-2-13	A B	90°	Para	A1035 ^c	12.8 12.8	12.8	15800	61	1
107	8-5-90-0-i-3.5-2-18	A B	90°	Para	A1035 ^b	19.0 18.0	18.5	5380	11	1
108	8-5-90-0-i-3.5-2-13	A B	90°	Para	A1035 ^b	13.4 13.4	13.4	5560	11	1
109	8-5-90-0-i-3.5-2-15(2)	A B	90°	Para	A1035 ^c	15.6 14.9	15.3	5180	8	1
110	8-5-90-0-i-3.5-2-15(1)	A B	90°	Para	A1035 ^c	15.4 15.1	15.3	6440	9	1
111	8-8-90-0-i-3.5-2-8(1)	A B	90°	Para	A1035 ^b	7.8 7.8	7.8	7910	15	1
112	8-8-90-0-i-3.5-2-10	A B	90°	Para	A1035 ^b	8.8 10.8	9.8	7700	14	1
113	8-8-90-0-i-3.5-2-8(2)	A B	90°	Para	A1035 ^b	8.5 8.0	8.3	8780	13	1
114	8-12-90-0-i-3.5-2-9	A B	90°	Para	A1035 ^b	9.0 9.0	9.0	11160	77	1
115	8-8-90-0-i-4-2-8	A B	90°	Para	A1035 ^b	7.6 8.0	7.8	8740	12	1
116	8-5-180-0-i-2.5-2-11	A B	180°	Para	A615	11.0 11.0	11.0	4550	7	1
117	8-5-180-0-i-2.5-2-14	A B	180°	Para	A1035 ^b	14.0 14.0	14.0	4840	8	1
118	(2@3) 8-5-180-0-i-2.5-2-10 [‡]	A B	180°	Para	A615	10.3 10.0	10.2	5260	15	1
119	(2@5)8-5-180-0-i-2.5-2-10 [‡]	A B	180°	Para	A615	10.0 10.0	10.0	5260	15	1
120	8-8-180-0-i-2.5-2-11.5	A B	180°	Para	A1035 ^b	9.3 9.3	9.3	8630	11	1
121	8-12-180-0-i-2.5-2-12.5	A B	180°	Para	A1035 ^c	12.8 12.5	12.6	11850	39	1
122	8-5-180-0-i-3.5-2-11	A B	180°	Para	A615	11.6 11.6	11.6	4550	7	1
123	8-5-180-0-i-3.5-2-14	A B	180°	Para	A1035 ^b	14.4 13.9	14.1	4840	8	1
124	8-15-180-0-i-2.5-2-13.5	A B	180°	Para	A1035 ^c	13.8 13.5	13.6	16510	88	1
125	8-5-90-1#3-i-2.5-2-16	A B	90°	Para	A1035 ^b	15.6 15.6	15.6	4810	6	1
126	8-5-90-1#3-i-2.5-2-12.5	A B	90°	Para	A1035 ^b	12.5 12.5	12.5	5140	8	1
127	8-5-90-1#3-i-2.5-2-9.5	A B	90°	Para	A615	9.0 9.0	9.0	5240	9	1
128	8-5-180-1#3-i-2.5-2-11	A B	180°	Para	A615	11.5 11.5	11.5	4300	6	1
129	8-5-180-1#3-i-2.5-2-14	A B	180°	Para	A1035 ^b	14.8 15.0	14.9	4870	9	1
130	8-5-180-1#3-i-3.5-2-11	A B	180°	Para	A615	11.6 10.6	11.1	4550	7	1
131	8-5-180-1#3-i-3.5-2-14	A B	180°	Para	A1035 ^b	15.6 14.5	15.1	4840	8	1

[‡] Specimen contained A1035 Grade 120 for column longitudinal steel

^a Heat 1, ^b Heat 2, ^c Heat 3 as described in Table 2.3

Table B.2 Cont. Comprehensive test results and data for No. 8 specimens with two hooks

	Hook	R_r	b in.	h in.	h_{cl} in.	h_c in.	c_{so} in.	$c_{so,avg}$ in.	c_{th} in.	c_h in.	N_h	Axial Load kips	Long. Reinf. Layout ^o
106	A B	0.073	16.8	14.8	10.5	8.375	2.4 2.5	2.4	2.1 2.0	9.9	2	30	A7
107	A B	0.078	18.5	20.4	10.5	8.375	3.8 3.4	3.6	1.4 2.4	9.4	2	30	A6
108	A B	0.078	18.4	15.3	10.5	8.375	3.6 3.4	3.5	1.9 1.9	9.4	2	30	A2
109	A B	0.073	18.5	17.3	10.5	8.375	3.5 3.5	3.5	1.6 2.4	9.5	2	30	A2
110	A B	0.073	18.8	17.1	10.5	8.375	3.3 3.4	3.3	1.8 2.0	10.1	2	30	A2
111	A B	0.078	18.3	10.0	10.5	8.375	3.5 3.8	3.6	2.3 2.3	9.0	2	30	A2
112	A B	0.078	18.5	12.0	10.5	8.375	3.8 3.8	3.8	3.3 1.3	9.0	2	30	A2
113	A B	0.078	19.4	10.6	10.5	8.375	3.6 3.8	3.7	2.1 2.6	10.0	2	30	A2
114	A B	0.078	19.0	11.3	10.5	8.375	3.5 3.8	3.6	2.4 2.1	9.8	2	30	A2
115	A B	0.078	19.9	10.5	10.5	8.375	4.5 3.9	4.2	2.9 2.5	9.5	2	30	A2
116	A B	0.078	17.5	13.0	10.5	8.375	3.0 2.8	2.9	2.0 2.0	9.8	2	80	A2
117	A B	0.078	17.1	16.0	10.5	8.375	2.8 2.6	2.7	2.0 2.0	9.8	2	80	A2
118	A B	0.073	8.9	12.0	10.5	8.375	2.5 2.4	2.4	1.7 2.0	2.0	2	30	A10
119	A B	0.073	11.0	12.0	10.5	8.375	2.4 2.5	2.4	2.0 2.0	4.1	2	30	A10
120	A B	0.078	17.5	13.8	10.5	8.375	3.0 3.0	3.0	4.5 4.5	9.5	2	30	A2
121	A B	0.073	17.1	14.9	10.5	8.375	3.0 2.5	2.8	2.1 2.4	9.6	2	30	A2
122	A B	0.078	19.5	13.0	10.5	8.375	3.8 3.8	3.8	1.4 1.4	10.0	2	80	A2
123	A B	0.078	19.4	16.0	10.5	8.375	3.9 3.8	3.8	1.6 2.1	9.8	2	80	A2
124	A B	0.073	17.0	15.8	10.5	8.375	2.5 2.5	2.5	2.0 2.3	10.0	2	30	A7
125	A B	0.078	17.3	17.9	10.5	8.375	2.8 3.0	2.9	2.3 2.3	9.5	2	80	A2
126	A B	0.078	17.1	14.6	10.5	8.375	2.6 2.8	2.7	2.1 2.1	9.8	2	80	A2
127	A B	0.078	17.1	11.5	10.5	8.375	2.6 2.8	2.7	2.5 2.5	9.8	2	80	A2
128	A B	0.078	17.0	13.0	10.5	8.375	2.5 2.5	2.5	1.5 1.5	10.0	2	80	A2
129	A B	0.078	17.5	16.0	10.5	8.375	2.8 2.9	2.8	1.3 1.0	9.9	2	80	A2
130	A B	0.078	19.3	13.0	10.5	8.375	3.8 3.5	3.6	1.4 2.4	10.0	2	80	A2
131	A B	0.078	19.3	16.5	10.5	8.375	3.6 3.6	3.6	0.9 2.0	10.0	2	80	A2

^o Longitudinal column configurations shown in Appendix A, Figures A1 – A16

Table B.2 Cont. Comprehensive test results and data for No. 8 specimens with two hooks

	Hook	T_{max} lb	T_{ind} lb	T_{total} lb	T lb	T_h lb	T/T_h	$f_{su,max}$ psi	f_{su} psi	$f_{s,ACI}$ psi	Joint shear at failure/ $\sqrt{f_{cm}}$
106	A	77232	77232	156239	78120	81605	0.96	97762	98885	114756	3.0
	B	79007	79007					100009			
107	A	96026	96026	190743	95372	88362	1.08	121552	120724	96925	4.2
	B	105140	94717					133089			
108	A	69449	67892	136199	68099	63253	1.08	87910	86202	71237	3.9
	B	68307	68307					86464			
109	A	106184	89959	175417	87709	71213	1.23	134410	111024	78398	4.6
	B	85459	85459					108176			
110	A	71216	70412	141302	70651	75854	0.93	90146	89432	87415	3.3
	B	79405	70890					100512			
111	A	43697	43697	87690	43845	39289	1.12	55313	55500	49234	3.3
	B	43993	43993					55687			
112	A	55230	55088	111134	55567	49724	1.12	69911	70338	61111	3.5
	B	71880	56046					90987			
113	A	41170	41170	84069	42034	43271	0.97	52114	53208	55217	2.6
	B	42930	42899					54341			
114	A	61380	61380	120477	60238	50870	1.18	77696	76251	67912	3.2
	B	68385	59097					86563			
115	A	37554	37554	74863	37431	40788	0.92	47537	47381	52170	2.3
	B	48708	37309					61656			
116	A	45587	45587	92286	46143	48511	0.95	57705	58409	52999	3.6
	B	50511	46699					63938			
117	A	49439	49439	98305	49152	63773	0.77	62581	62218	69570	3.1
	B	69415	48866					87867			
118	A	47587	47587	103651	51825	46490	1.11	60236	65602	52614	8.1
	B	56064	56064					70967			
119	A	52300	52300	106330	53165	45732	1.16	66202	67297	51804	6.7
	B	54030	54030					68392			
120	A	62777	62777	142967	71484	48606	1.47	79465	90485	61379	3.9
	B	80190	80190					101506			
121	A	74782	74782	150417	75208	74101	1.01	94661	95201	98166	3.3
	B	92250	75635					116772			
122	A	58575	58145	118584	59292	51437	1.15	74145	75053	56011	4.2
	B	60519	60439					76606			
123	A	63745	63689	127009	63504	64377	0.99	80690	80385	70191	3.6
	B	78050	63320					98797			
124	A	90688	90688	179833	89916	88447	1.02	114795	113818	125050	3.2
	B	89145	89145					112841			
125	A	94588	75682	149617	74809	76769	0.97	119731	94694	77429	4.2
	B	73936	73936					93589			
126	A	73919	64891	129674	64837	62777	1.03	93569	82072	64012	4.4
	B	64783	64783					82004			
127	A	62525	59716	124467	62233	46082	1.35	79145	78776	46535	5.3
	B	65289	64750					82645			
128	A	57294	48342	99464	49732	55252	0.90	72524	62952	53865	4.2
	B	68950	51122					87278			
129	A	67269	67183	138043	69021	73355	0.94	85150	87369	74147	4.3
	B	70909	70860					89758			
130	A	62945	54681	110781	55390	54323	1.02	79678	70114	53602	4.0
	B	56154	56100					71082			
131	A	78657	75069	151988	75994	74142	1.02	99565	96195	74850	4.2
	B	76919	76919					97366			

Table B.2 Cont. Comprehensive test results and data for No. 8 specimens with two hooks

	Hook	Slip at Failure in.	Failure Type	f_{yt} ksi	d_{tr} in.	$A_{tr,l}$ in. ²	N_{tr}	S_{tr} in.	A_{cti} in. ²	N_{cti}	S_{cti} in.	d_s in.	s_s in.	d_{cto} in.	N_{cto}	A_s in. ²	f_{ys} ksi
106	A B	- -	F/S F	60	-	-	-	-	-	-	-	0.38	5.00	-	-	4.74	60
107	A B	0.181 -	F/S/TK F/S	60	-	-	-	-	1.10	10	3.0	0.38	3.50	0.375	1	3.78	60
108	A B	- -	F/S S/F	60	-	-	-	-	1.00	5	3.0	0.50	3.00	0.375	1	3.16	60
109	A B	- -	S S/F	60	-	-	-	-	1.10	10	3.0	0.38	3.50	0.375	2	3.16	60
110	A B		S/F S	60	-	-	-	-	1.10	10	3.0	0.38	3.50	0.375	2	3.16	60
111	A B	0.144 0.156	S/F S/F	60	-	-	-	-	1.60	8	4.0	0.50	1.75	-	-	3.16	60
112	A B	0.195 0.242	F/S S/F	60	-	-	-	-	1.60	8	4.0	0.63	3.50	-	-	3.16	60
113	A B	0.133 0.201	F F	60	-	-	-	-	1.60	8	4.0	0.50	1.50	-	-	3.16	60
114	A B	- 0.434	F F/S	60	-	-	-	-	0.88	8	4.0	0.50	4.00	0.375	2	3.16	60
115	A B	- -	F/S F	60	-	-	-	-	1.60	8	4.0	0.50	1.75	-	-	3.16	60
116	A B	0.275 -	S/F S	60	-	-	-	-	0.44	4	3.5	0.50	3.50	-	-	3.16	60
117	A B	0.088 0.096	S S	60	-	-	-	-	0.44	4	3.5	0.50	3.50	-	-	3.16	60
118	A B	0 0.9	F F	60	-	-	-	-	-	-	-	0.50	4.00	-	-	6.32	120
119	A B		F F	60	-	-	-	-	-	-	-	0.50	4.00	-	-	6.32	120
120	A B	- -	F/S F/S	60	-	-	-	-	0.44	4	3.0	0.50	3.00	-	-	3.16	60
121	A B	0.193 0.242	F/S F	60	-	-	-	-	-	-	-	0.50	2.25	-	-	3.16	60
122	A B	0.372 0.239	F/S S	60	-	-	-	-	0.44	4	3.5	0.50	3.50	-	-	3.16	60
123	A B	- -	S F/S	60	-	-	-	-	0.44	4	3.5	0.50	3.50	-	-	3.16	60
124	A B	- -	- F/S	60	-	-	-	-	-	-	-	0.50	4.00	-	-	4.74	60
125	A B	- -	F/S F/S	60	0.38	0.11	1	9.00	2.00	10	3.0	0.50	3.00	-	-	3.16	60
126	A B	- -	F/S S/F	60	0.38	0.11	1	9.00	2.00	10	3.0	0.50	3.00	-	-	3.16	60
127	A B	- -	S F/S	60	0.38	0.11	1	9.00	2.00	10	3.0	0.50	3.00	-	-	3.16	60
128	A B	0.088 0.341	S/F S/F	60	0.38	0.11	1	3.50	0.44	4	4.5	0.50	3.50	-	-	3.16	60
129	A B	- 0.123	S/F F/S	60	0.38	0.11	1	3.50	0.44	4	4.5	0.50	3.50	-	-	3.16	60
130	A B	0.434 0.216	S S	60	0.38	0.11	1	3.50	0.44	4	4.5	0.50	3.50	-	-	3.16	60
131	A B	0.232 0.227	S/F S/F	60	0.38	0.11	1	3.50	0.44	4	4.5	0.50	3.50	-	-	3.16	60

Table B.2 Cont. Comprehensive test results and data for No. 8 specimens with two hooks

	Specimen	Hook	Bend Angle	Trans. Reinf. Orient.	Hook Bar Type	l_{eh} in.	$l_{eh,avg}$ in.	f'_c psi	Age days	d_b in.
132	8-8-180-1#4-i-2.5-2-11.5	A B	180°	Para	A1035 ^b	12.0 12.3	12.1	8740	12	1
133	8-5-90-2#3-i-2.5-2-16	A B	90°	Para	A1035 ^b	15.0 15.8	15.4	4810	6	1
134	8-5-90-2#3-i-2.5-2-9.5	A B	90°	Para	A615	9.0 9.3	9.1	5140	8	1
135	8-5-90-2#3-i-2.5-2-12.5	A B	90°	Para	A615	12.0 12.0	12.0	5240	9	1
136	8-5-90-2#3-i-2.5-2-8.5	A B	90°	Para	A1035 ^c	8.9 9.6	9.3	5240	6	1
137	8-5-90-2#3-i-2.5-2-14	A B	90°	Para	A1035 ^c	13.5 14.0	13.8	5450	7	1
138	(2@3) 8-5-90-2#3-i-2.5-2-10 [‡]	A B	90°	Para	A615	10.0 10.5	10.3	4760	11	1
139	(2@5) 8-5-90-2#3-i-2.5-2-10 [‡]	A B	90°	Para	A615	9.6 10.0	9.8	4760	11	1
140	8-8-90-2#3-i-2.5-2-8	A B	90°	Para	A1035 ^b	8.0 8.5	8.3	7700	14	1
141	8-8-90-2#3-i-2.5-2-10	A B	90°	Para	A1035 ^b	9.9 9.5	9.7	8990	17	1
142	8-12-90-2#3-i-2.5-2-9	A B	90°	Para	A1035 ^b	9.0 9.0	9.0	11160	77	1
143	8-12-90-2#3-i-2.5-2-11	A B	90°	Para	A1035 ^c	10.5 11.3	10.9	12010	42	1
144	8-12-90-2#3vr-i-2.5-2-11	A B	90°	Perp	A1035 ^c	10.9 10.4	10.6	12010	42	1
145	8-15-90-2#3-i-2.5-2-6	A B	90°	Para	A1035 ^c	5.8 6.4	6.1	15800	61	1
146	8-15-90-2#3-i-2.5-2-11	A B	90°	Para	A1035 ^c	11.3 10.8	11.0	15800	61	1
147	8-5-90-2#3-i-3.5-2-17	A B	90°	Para	A1035 ^b	17.5 17.0	17.3	5570	12	1
148	8-5-90-2#3-i-3.5-2-13	A B	90°	Para	A1035 ^b	13.8 13.5	13.6	5560	11	1
149	8-8-90-2#3-i-3.5-2-8	A B	90°	Para	A1035 ^b	8.0 8.1	8.1	8290	16	1
150	8-8-90-2#3-i-3.5-2-10	A B	90°	Para	A1035 ^b	8.8 8.8	8.8	8990	17	1
151	8-12-90-2#3-i-3.5-2-9	A B	90°	Para	A1035 ^b	9.0 9.0	9.0	11160	77	1
152	8-5-180-2#3-i-2.5-2-11	A B	180°	Para	A615	10.8 10.5	10.6	4550	7	1
153	8-5-180-2#3-i-2.5-2-14	A B	180°	Para	A1035 ^b	13.5 14.0	13.8	4870	9	1
154	(2@3) 8-5-180-2#3-i-2.5-2-10 [‡]	A B	180°	Para	A615	10.3 10.3	10.3	5400	16	1
155	(2@5) 8-5-180-2#3-i-2.5-2-10 [‡]	A B	180°	Para	A615	10.3 9.8	10.0	5400	16	1
156	8-8-180-2#3-i-2.5-2-11.5	A B	180°	Para	A1035 ^b	10.5 10.3	10.4	8810	14	1

[‡] Specimen contained A1035 Grade 120 for column longitudinal steel

^a Heat 1, ^b Heat 2, ^c Heat 3 as described in Table 2.3

Table B.2 Cont. Comprehensive test results and data for No. 8 specimens with two hooks

	Hook	R_r	b in.	h in.	h_{cl} in.	h_c in.	c_{so} in.	$c_{so,avg}$ in.	c_{th} in.	c_h in.	N_h	Axial Load kips	Long. Reinf. Layout ^o
132	A B	0.078	17.1	14.0	10.5	8.375	2.9 2.8	2.8	2.0 1.8	9.5	2	30	A2
133	A B	0.078	17.1	17.9	10.5	8.375	2.8 2.9	2.8	2.9 2.1	9.5	2	80	A2
134	A B	0.078	17.0	11.6	10.5	8.375	2.5 2.5	2.5	2.6 2.3	10.0	2	80	A2
135	A B	0.078	17.0	14.6	10.5	8.375	2.8 2.8	2.8	2.6 2.6	9.5	2	80	A2
136	A B	0.073	17.1	10.7	10.5	8.375	3.0 3.0	3.0	1.8 1.1	9.1	2	30	A2
137	A B	0.073	17.0	16.1	10.5	8.375	2.8 3.0	2.9	2.6 2.1	9.3	2	30	A2
138	A B	0.073	9.3	12.0	10.5	8.375	2.5 2.5	2.5	2.0 1.5	2.3	2	30	A2
139	A B	0.073	10.9	12.0	10.5	8.375	2.5 2.5	2.5	2.4 2.0	3.9	2	30	A2
140	A B	0.078	16.9	10.0	10.5	8.375	3.0 2.9	2.9	2.0 1.5	9.0	2	30	A2
141	A B	0.078	16.0	12.0	10.5	8.375	2.8 2.8	2.8	2.1 2.5	8.5	2	30	A2
142	A B	0.078	17.0	11.3	10.5	8.375	2.9 2.6	2.8	2.3 2.3	9.5	2	30	A2
143	A B	0.073	17.0	12.9	10.5	8.375	2.8 2.8	2.8	2.4 1.6	9.5	2	30	A2
144	A B	0.073	16.5	13.0	10.5	8.375	2.5 2.3	2.4	2.1 2.6	9.8	2	30	A2
145	A B	0.073	16.8	8.1	10.5	8.375	2.5 2.4	2.4	2.3 1.8	9.9	2	30	A11
146	A B	0.073	17.0	13.1	10.5	8.375	2.5 2.5	2.5	1.9 2.4	10.0	2	30	A11
147	A B	0.078	18.9	19.3	10.5	8.375	3.3 3.5	3.4	1.8 2.3	10.1	2	30	A2
148	A B	0.078	19.0	15.3	10.5	8.375	3.1 3.6	3.4	1.5 1.8	10.3	2	30	A2
149	A B	0.078	17.9	10.0	10.5	8.375	3.6 3.8	3.7	2.0 1.9	8.5	2	30	A2
150	A B	0.078	17.9	12.0	10.5	8.375	3.6 3.8	3.7	3.3 3.3	8.5	2	30	A2
151	A B	0.078	19.3	11.3	10.5	8.375	3.6 4.0	3.8	2.3 2.4	9.6	2	30	A2
152	A B	0.078	16.8	13.0	10.5	8.375	2.8 2.5	2.6	2.3 2.5	9.5	2	80	A2
153	A B	0.078	17.3	16.0	10.5	8.375	2.8 2.8	2.8	2.5 2.0	9.8	2	80	A2
154	A B	0.073	9.0	12.0	10.5	8.375	2.5 2.5	2.5	1.8 1.8	2.0	2	30	A10
155	A B	0.073	11.0	12.0	10.5	8.375	2.5 2.5	2.5	1.8 2.3	4.0	2	30	A10
156	A B	0.078	17.5	12.8	10.5	8.375	2.8 2.8	2.8	2.3 2.5	10.0	2	30	A2

^o Longitudinal column configurations shown in Appendix A, Figures A1 – A16

Table B.2 Cont. Comprehensive test results and data for No. 8 specimens with two hooks

	Hook	T_{max} lb	T_{ind} lb	T_{total} lb	T lb	T_h lb	T/T_h	$f_{su,max}$ psi	f_{su} psi	$f_{s,ACI}$ psi	Joint shear at failure/ $\sqrt{f_{cm}}$
132	A B	72047 72506	71987 72475	144462	72231	74846	0.97	91199 91780	91432	80967	3.9
133	A B	80014 92780	79629 79629	159258	79629	75532	1.05	101284 117443	100796	76166	4.5
134	A B	54916 53621	53621 53621	107242	53621	46453	1.15	69513 67874	67874	46729	4.6
135	A B	74108 76334	67801 76334	144135	72067	60649	1.19	93808 96625	91225	62047	4.9
136	A B	52863 48439	52862 48260	101122	50561	47286	1.07	66915 61315	64001	47828	4.6
137	A B	76959 77540	76388 77540	153927	76964	69985	1.10	97416 98151	97422	72506	4.6
138	A B	58584 47051	58435 35184	93619	46810	50832	0.92	74157 59558	59253	50513	7.4
139	A B	48430 48617	48412 48617	97029	48515	48772	0.99	61303 61541	61411	48357	6.5
140	A B	46211 55377	46211 49540	95751	47876	46882	1.02	58495 70098	60602	51710	3.9
141	A B	60670 67001	60670 61378	122047	61024	56882	1.07	76797 84812	77245	65609	4.1
142	A B	61813 60251	61813 60213	122026	61013	56097	1.09	78244 76267	77232	67912	3.7
143	A B	68128 79794	68101 69264	137365	68683	68734	1.00	86237 101004	86940	85128	3.5
144	A B	50709 66830	50709 54637	105346	52673	64971	0.81	64188 84595	66674	83171	2.7
145	A B	37450 37689	37450 37689	75138	37569	42443	0.89	47405 47707	47556	54712	2.7
146	A B	99011 83603	83072 83567	166640	83320	74830	1.11	125330 105827	105468	98763	3.6
147	A B	102613 88572	91402 88426	179829	89914	88104	1.02	129889 112117	113816	91958	4.0
148	A B	81199 86858	81199 79522	160720	80360	69734	1.15	102783 109946	101722	72568	4.5
149	A B	48324 49258	48324 49222	97545	48773	46759	1.04	61169 62352	61738	52435	3.6
150	A B	53960 53810	53960 53810	107770	53885	51599	1.04	68304 68113	68209	59260	3.2
151	A B	50266 49289	50266 49289	99555	49777	56097	0.89	63628 62391	63009	67912	2.6
152	A B	64232 61892	58650 61819	120469	60235	57658	1.04	81306 78345	76246	51193	5.0
153	A B	87080 76851	75744 76814	152558	76279	73578	1.04	110228 97279	96556	68539	4.8
154	A B	57472 58835	57188 58114	115302	57651	52531	1.10	72749 74474	72976	53801	8.8
155	A B	63698 60130	63640 60130	123770	61885	51309	1.21	80630 76114	78335	52489	7.7
156	A B	70102 59494	56934 59408	116343	58171	66123	0.88	88737 75309	73635	69558	3.4

Table B.2 Cont. Comprehensive test results and data for No. 8 specimens with two hooks

	Hook	Slip at Failure in.	Failure Type	f_{yt} ksi	d_{tr} in.	$A_{tr,t}$ in. ²	N_{tr}	s_{tr} in.	A_{cti} in. ²	N_{cti}	s_{cti} in.	d_s in.	s_s in.	d_{cto} in.	N_{cto}	A_s in. ²	f_{ys} ksi
132	A B	- (.013)	F/S F/S	60	0.5	0.20	1	3.00	0.44	4	3.0	0.50	3.00	-	-	3.16	60
133	A B	- -	S/F F	60	0.38	0.11	2	3.00	2.00	10	3.0	0.50	3.00	-	-	3.16	60
134	A B	- -	F F	60	0.38	0.11	2	3.00	2.00	10	3.0	0.50	3.00	-	-	3.16	60
135	A B	- -	F F/S	60	0.38	0.11	2	3.00	2.00	10	3.0	0.50	3.00	-	-	3.16	60
136	A B		F/S S	60	0.38	0.11	2	7.50	2.00	10	2.5	0.50	3.25	0.5	1	3.16	60
137	A B		S/F F/S	60	0.38	0.11	2	6.00	0.88	8	3.0	0.50	3.50	0.5	1	3.16	60
138	A B	0.21 -	F F	60	0.38	0.11	2	3.00	-	-	-	0.38	4.00	-	-	3.16	120
139	A B	0.23 0.108	F F	60	0.38	0.11	2	3.00	-	-	-	0.38	5.00	-	-	3.16	120
140	A B	- -	F/S F/S	60	0.38	0.11	2	7.13	1.20	6	4.0	0.50	1.50	-	-	3.16	60
141	A B	0.186 0.152	F F	60	0.38	0.11	2	7.13	1.20	6	4.0	0.63	3.50	-	-	3.16	60
142	A B	0.345 0.361	F/S S/F	60	0.38	0.11	2	8.00	0.88	8	4.0	0.50	4.00	0.375	2	3.16	60
143	A B	0.181 0.165	F F	60	0.38	0.11	2	8.00	-	-	-	0.50	2.00	-	-	3.16	60
144	A B	- 0.13	F/S F	60	0.38	0.11	2	2.67	-	-	-	0.50	2.00	-	-	3.16	60
145	A B	- -	F F	60	0.38	0.11	2	6.00	-	-	-	0.38	2.75	-	-	6.32	60
146	A B	- 0.123	F F	60	0.38	0.11	2	5.50	-	-	-	0.38	4.00	-	-	6.32	60
147	A B	- -	S S/F	60	0.38	0.11	2	8.00	0.80	4	4.0	0.50	4.00	0.375	1	3.16	60
148	A B	- -	S/F S/F	60	0.38	0.11	2	8.00	0.44	4	4.0	0.50	3.00	-	-	3.16	60
149	A B	0.31 .340(.147)	F F	60	0.38	0.11	2	7.13	1.20	6	4.0	0.50	1.50	-	-	3.16	60
150	A B	- -	S F	60	0.38	0.11	2	7.13	1.20	6	4.0	0.63	3.50	-	-	3.16	60
151	A B	0.15	F/S F/S	60	0.38	0.11	2	8.00	0.88	8	4.0	0.50	4.00	0.375	2	3.16	60
152	A B	0.26 0.087	S/F S/F	60	0.38	0.11	2	3.50	-	-	-	0.50	3.50	-	-	3.16	60
153	A B	0.774 0.199	F F/S	60	0.38	0.11	2	3.50	-	-	-	0.50	3.50	-	-	3.16	60
154	A B	0.288	F F	60	0.38	0.11	2	3.00	-	-	-	0.50	4.00	-	-	6.32	120
155	A B	0.263	F F	60	0.38	0.11	2	3.00	-	-	-	0.50	4.00	-	-	6.32	120
156	A B	0.261 .25(.027)	F/S F/S	60	0.38	0.11	2	3.00	-	-	-	0.50	3.00	-	-	3.16	60

Table B.2 Cont. Comprehensive test results and data for No. 8 specimens with two hooks

	Specimen	Hook	Bend Angle	Trans. Reinf. Orient.	Hook Bar Type	l_{eh} in.	$l_{eh,avg}$ in.	f'_c psi	Age days	d_b in.
157	8-12-180-2#3-i-2.5-2-11	A B	180°	Para	A1035 ^c	11.1 10.4	10.8	12010	42	1
158	8-12-180-2#3vr-i-2.5-2-11	A B	180°	Perp	A1035 ^b	10.9 10.9	10.9	12010	42	1
159	8-5-180-2#3-i-3.5-2-11	A B	180°	Para	A1035 ^b	10.1 10.6	10.4	4300	6	1
160	8-5-180-2#3-i-3.5-2-14	A B	180°	Para	A1035 ^b	13.5 13.6	13.6	4870	9	1
161	8-15-180-2#3-i-2.5-2-11	A B	180°	Para	A1035 ^b	11.1 11.1	11.1	15550	87	1
162	8-8-90-2#4-i-2.5-2-10	A B	90°	Para	A1035 ^b	8.5 9.3	8.9	8290	16	1
163	8-8-90-2#4-i-3.5-2-10	A B	90°	Para	A1035 ^b	9.0 9.8	9.4	8290	16	1
164	8-5-90-4#3-i-2.5-2-16	B A	90°	Para	A1035 ^b	16.0 16.3	16.1	4810	6	1
165	8-5-90-4#3-i-2.5-2-12.5	A B	90°	Para	A1035 ^b	11.9 11.9	11.9	4980	7	1
166	8-5-90-4#3-i-2.5-2-9.5	A B	90°	Para	A615	9.5 9.5	9.5	5140	8	1
167	8-5-90-5#3-o-2.5-2-10a	A B	90°	Para	A1035 ^a	10.3 10.5	10.4	5270	7	1
168	8-5-90-5#3-o-2.5-2-10b	A B	90°	Para	A1035 ^a	10.5 10.5	10.5	5440	8	1
169	8-5-90-5#3-o-2.5-2-10c	A B	90°	Para	A1035 ^a	11.3 10.5	10.9	5650	9	1
170	8-8-90-5#3-o-2.5-2-8	A B	90°	Para	A1035 ^b	8.3 8.8	8.5	8630	11	1
171	8-8-90-5#3-o-3.5-2-8	A B	90°	Para	A1035 ^b	7.8 8.0	7.9	8810	14	1
172	8-8-90-5#3-o-4-2-8	A B	90°	Para	A1035 ^b	8.5 8.0	8.3	8740	12	1
173	8-5-90-5#3-i-2.5-2-10b	A B	90°	Para	A1035 ^a	10.3 10.5	10.4	5440	8	1
174	8-5-90-5#3-i-2.5-2-10c	A B	90°	Para	A1035 ^a	10.5 10.5	10.5	5650	9	1
175	8-5-90-5#3-i-2.5-2-15	A B	90°	Para	A1035 ^b	15.3 15.8	15.5	4850	7	1
176	8-5-90-5#3-i-2.5-2-13	A B	90°	Para	A1035 ^b	13.8 13.5	13.6	5560	11	1
177	8-5-90-5#3-i-2.5-2-12(1)	A B	90°	Para	A1035 ^c	11.5 11.1	11.3	5090	7	1
178	8-5-90-5#3-i-2.5-2-12	A B	90°	Para	A1035 ^c	11.3 12.3	11.8	5960	7	1
179	8-5-90-5#3-i-2.5-2-12(2)	A B	90°	Para	A1035 ^c	12.4 12.0	12.2	5240	6	1
180	8-5-90-5#3-i-2.5-2-8	A B	90°	Para	A1035 ^c	7.8 7.4	7.6	5240	6	1
181	8-5-90-5#3-i-2.5-2-10a	B	90°	Para	A1035 ^a	10.5	10.5	5270	7	1
182	(2@3) 8-5-90-5#3-i-2.5-2-10 [‡]	A B	90°	Para	A615	10.0 10.5	10.3	4805	12	1

[‡] Specimen contained A1035 Grade 120 for column longitudinal steel

^a Heat 1, ^b Heat 2, ^c Heat 3 as described in Table 2.3

Table B.2 Cont. Comprehensive test results and data for No. 8 specimens with two hooks

	Hook	R_r	b in.	h in.	h_{cl} in.	h_c in.	c_{so} in.	$c_{so,avg}$ in.	c_{th} in.	c_h in.	N_h	Axial Load kips	Long. Reinf. Layout ^o
157	A B	0.073	16.8	13.2	10.5	8.375	2.5 2.6	2.6	2.1 2.8	9.6	2	30	A2
158	A B	0.073	17.1	13.3	10.5	8.375	2.8 2.6	2.7	2.4 2.4	9.8	2	30	A2
159	A B	0.078	18.6	13.0	10.5	8.375	3.4 3.5	3.4	2.9 2.4	9.8	2	80	A2
160	A B	0.078	19.1	16.0	10.5	8.375	3.6 3.8	3.7	2.5 2.4	9.8	2	80	A2
161	A B	0.073	17.3	13.1	10.5	8.375	2.8 2.8	2.8	2.1 2.0	9.8	2	30	A7
162	A B	0.078	17.3	12.0	10.5	8.375	3.0 3.0	3.0	3.5 2.8	9.3	2	30	A2
163	A B	0.078	18.8	12.0	10.5	8.375	3.8 3.9	3.8	3.0 2.3	9.1	2	30	A2
164	B A	0.078	17.3	17.9	10.5	8.375	2.8 3.0	2.9	1.9 1.6	9.5	2	80	A2
165	A B	0.078	17.0	13.9	10.5	8.375	2.5 2.5	2.5	2.0 2.0	10.0	2	80	A2
166	A B	0.078	17.1	11.5	10.5	8.375	2.8 2.9	2.8	2.0 2.0	9.5	2	80	A2
167	A B	0.084	17.1	12.3	10.5	8.375	2.6 2.6	2.6	1.8 2.0	9.9	2	80	A2
168	A B	0.084	17.0	12.5	10.5	8.375	2.5 2.6	2.6	2.0 2.0	9.9	2	80	A2
169	A B	0.084	17.0	12.5	10.5	8.375	2.6 2.5	2.6	1.3 2.0	9.9	2	80	A2
170	A B	0.078	16.8	10.0	10.5	8.375	2.8 2.8	2.8	1.8 1.3	9.3	2	30	A2
171	A B	0.078	18.5	10.0	10.5	8.375	3.5 3.5	3.5	2.3 2.0	9.5	2	30	A2
172	A B	0.078	20.4	10.0	10.5	8.375	3.9 4.5	4.2	1.5 2.0	10.0	2	30	A2
173	A B	0.084	17.3	12.3	10.5	8.375	2.8 2.6	2.7	2.0 1.8	9.9	2	80	A2
174	A B	0.084	17.0	12.5	10.5	8.375	2.5 2.5	2.5	2.0 2.0	10.0	2	80	A2
175	A B	0.078	17.1	17.2	10.5	8.375	2.8 2.5	2.6	1.9 1.4	9.9	2	30	A2
176	A B	0.078	17.1	15.3	10.5	8.375	2.5 2.4	2.4	1.5 1.8	10.3	2	30	A2
177	A B	0.073	16.8	14.1	10.5	8.375	2.5 2.5	2.5	2.6 3.0	9.8	2	30	A2
178	A B	0.073	16.6	14.3	10.5	8.375	2.5 2.4	2.4	3.0 2.0	9.8	2	30	A2
179	A B	0.073	16.1	14.1	10.5	8.375	2.5 2.6	2.6	1.8 2.1	9.0	2	30	A2
180	A B	0.073	16.6	10.3	10.5	8.375	2.8 2.9	2.8	2.6 2.9	9.0	2	30	A2
181	B	0.08	17	12.3	10.5	8.375	2.5	2.5	1.8	9.8	2	80	A2
182	A B	0.073	9.2	12.0	10.5	8.375	2.4 2.8	2.6	2.0 1.5	2.0	2	30	A2

^o Longitudinal column configurations shown in Appendix A, Figures A1 – A16

Table B.2 Cont. Comprehensive test results and data for No. 8 specimens with two hooks

	Hook	T_{max} lb	T_{ind} lb	T_{total} lb	T lb	T_h lb	T/T_h	$f_{su,max}$ psi	f_{su} psi	$f_{s,ACI}$ psi	Joint shear at failure/ $\sqrt{f_{cm}}$
157	A B	73700 66170	63140 66170	129310	64655	67961	0.95	93291 83759	81842	84150	3.2
158	A B	67136 87053	67136 64423	131559	65780	66517	0.99	84983 110194	83265	85128	3.2
159	A B	57158 54943	56965 54772	111737	55869	55752	1.00	72352 69548	70720	48595	4.3
160	A B	68293 90408	68293 58642	126934	63467	72672	0.87	86446 114441	80338	67605	3.6
161	A B	79626 78291	79553 78291	157845	78922	75135	1.05	100792 99103	99902	98813	3.4
162	A B	61367 71322	61286 61434	122721	61360	55832	1.10	77680 90281	77671	57719	3.9
163	A B	69451 69474	69451 69474	138925	69463	58583	1.19	87913 87942	87927	60971	4.1
164	B A	91801 97200	91801 89056	180857	90429	84844	1.07	116204 123038	114467	79881	5.1
165	A B	83079 68634	68532 68634	137165	68583	64929	1.06	105164 86878	86814	59883	5.0
166	A B	63275 54846	55094 54733	109827	54914	53922	1.02	80094 69425	69511	48649	4.7
167	A B	55700 55774	53308 55206	108513	54257	64329	0.84	70507 70601	68679	67247	4.3
168	A B	66444 69470	61714 69470	131183	65592	65382	1.00	84107 87936	83027	69147	5.1
169	A B	80648 58800	80648 58340	138988	69494	67783	1.03	102086 74430	87967	72985	5.3
170	A B	56092 66796	56092 59870	115962	57981	61189	0.95	71002 84551	73394	70503	4.5
171	A B	53926 56134	53865 56048	109914	54957	57980	0.95	68261 71055	69566	65996	3.8
172	A B	39553 41461	39553 38589	78142	39071	59964	0.65	50067 52483	49457	68864	2.5
173	A B	78824 66728	75418 64012	139430	69715	64769	1.08	99777 84466	88247	68323	5.4
174	A B	68947 69633	68071 69604	137674	68837	65920	1.04	87275 88143	87136	70469	5.2
175	A B	77125 72603	74150 72603	146753	73377	87983	0.83	97627 91903	92882	96574	4.3
176	A B	93116 81340	83412 81340	164752	82376	81257	1.01	117868 102962	104273	90710	5.1
177	A B	66726 75878	66726 66001	132727	66363	68375	0.97	84463 96048	84004	72061	4.8
178	A B	84900 72000	* 72000	72000	72000	73010	0.99	107468 91139	91139	80992	2.4
179	A B	72359 77425	72321 70619	142939	71470	73090	0.98	91593 98006	90468	78770	5.3
180	A B	48024 47008	47948 47008	94956	47478	50723	0.94	60790 59503	60099	48878	4.6
181	B	82800	82800	82800	82800	64937	1.28	104800	104800	68100	3.4
182	A B	61451 58224	57620 58224	115845	57922	62480	0.93	77787 73702	73319	63438	9.2

Table B.2 Cont. Comprehensive test results and data for No. 8 specimens with two hooks

	Hook	Slip at Failure in.	Failure Type	f_{yt} ksi	d_{tr} in.	$A_{v,l}$ in. ²	N_{tr}	S_{tr} in.	A_{cti} in. ²	N_{cti}	S_{cti} in.	d_s in.	s_s in.	d_{cto} in.	N_{cto}	A_s in. ²	f_{ys} ksi
157	A B	- -	F F	60	0.375	0.11	2	8.00	-	-	-	0.50	2.00	-	-	3.16	60
158	A B	- 0.369	S/F F/S	60	0.375	0.11	2	2.67	-	-	-	0.50	2.00	-	-	3.16	60
159	A B	0.167 0.212	S/F S/F	60	0.375	0.11	2	3.50	-	-	-	0.50	3.50	-	-	3.16	60
160	A B	- -	F/S F/S	60	0.375	0.11	2	3.50	-	-	-	0.50	3.50	-	-	3.16	60
161	A B	- -	F/S F	60	0.375	0.11	2	5.00	-	-	-	0.50	4.00	-	-	4.74	60
162	A B	0.171 .285(.129)	F/S F/S	60	0.5	0.20	2	7.13	1.20	6	4.0	0.50	2.00	-	-	3.16	60
163	A B	0.26 .181(.104)	S/F F/S	60	0.5	0.20	2	7.13	1.20	6	4.0	0.50	2.00	-	-	3.16	60
164	B A	- -	F/S F/S	60	0.375	0.11	4	3.00	2.00	10	3.0	0.50	3.00	-	-	3.16	60
165	A B	- -	F F	60	0.375	0.11	4	3.00	2.00	10	3.0	0.50	3.00	-	-	3.16	60
166	A B	- -	F F/S	60	0.375	0.11	4	3.00	2.00	10	3.0	0.50	3.00	-	-	3.16	60
167	A B	- 0.213	S S	60	0.375	0.11	5	3.00	1.10	10	3.0	0.63	5.00	-	-	3.16	60
168	A B	0.203 0.235	F/S S/F	60	0.375	0.11	5	3.00	1.10	10	3.0	0.63	5.00	-	-	3.16	60
169	A B	- -	S/F S/F	60	0.375	0.11	5	3.00	1.10	10	3.0	0.63	5.00	-	-	3.16	60
170	A B	0.253 .237(.033)	F/S F/S	60	0.375	0.11	5	3.00	2.00	10	3.0	0.50	1.75	-	-	3.16	60
171	A B	- .251(.249)	F F/S	60	0.375	0.11	5	3.00	2.00	10	3.0	0.50	1.75	-	-	3.16	60
172	A B	0.388 0.754	S/F F	60	0.375	0.11	5	3.00	2.00	10	3.0	0.50	1.75	-	-	3.16	60
173	A B	0.129 -	F/S F	60	0.375	0.11	5	3.00	1.10	10	3.0	0.63	5.00	-	-	3.16	60
174	A B	- -	F/S F/S	60	0.375	0.11	5	3.00	1.10	10	3.0	0.63	5.00	-	-	3.16	60
175	A B	0.196 -	F/S F/S	60	0.375	0.11	5	3.00	0.55	5	3.0	0.38	3.50	0.375	2	3.16	60
176	A B	- -	S/F F/S	60	0.375	0.11	5	3.00	1.00	5	3.0	0.50	3.00	0.375	1	3.16	60
177	A B	- -	S/F S/F	60	0.375	0.11	5	3.00	0.55	5	3.0	0.38	3.50	0.5	2	3.16	60
178	A B		S S	60	0.375	0.11	5	3.00	0.55	5	3.0	0.38	3.50	0.5	2	3.16	60
179	A B		F/S F/S	60	0.375	0.11	5	3.00	0.55	5	3.0	0.38	3.50	0.375	1	3.16	60
180	A B	0.321	F F	60	0.375	0.11	5	3.00	1.55	5	3.0	0.50	3.00	0.5	1	3.16	60
181	B	0.164	F/S	60	0.375	0.11	5	3.0	1.10	10	3.0	0.63	3.50	-	-	3.16	60
182	A B	0.05 0.37	F/S F/S	60	0.375	0.11	5	3.00	-	-	-	0.38	4.00	-	-	3.16	120

Table B.2 Cont. Comprehensive test results and data for No. 8 specimens with two hooks

	Specimen	Hook	Bend Angle	Trans. Reinf. Orient.	Hook Bar Type	l_{eh} in.	$l_{eh,avg}$ in.	f'_c psi	Age days	d_b in.
183	(2@5) 8-5-90-5#3-i-2.5-2-10 [‡]	A B	90°	Para	A615	9.9 9.5	9.7	4805	12	1
184	8-8-90-5#3-i-2.5-2-8	A B	90°	Para	A1035 ^b	7.3 7.3	7.3	8290	16	1
185	8-8-90-5#3-i-2.5-2-9 [‡]	A B	90°	Para	A615	8.6 9.0	8.8	7710	25	1
186	8-8-90-5#3-i-2.5-9-9 [‡]	A B	90°	Para	A615	9.0 9.3	9.1	7710	25	1
187	(2@3) 8-8-90-5#3-i-2.5-9-9	A B	90°	Para	A615	9.3 9.5	9.4	7440	22	1
188	(2@4) 8-8-90-5#3-i-2.5-9-9	A B	90°	Para	A615	8.9 9.1	9.0	7440	22	1
189	8-12-90-5#3-i-2.5-2-9	A B	90°	Para	A1035 ^b	9.0 9.0	9.0	11160	77	1
190	8-12-90-5#3-i-2.5-2-10	A B	90°	Para	A1035 ^c	9.0 9.9	9.4	11800	38	1
191	8-12-90-5#3-i-2.5-2-12 [‡]	A B	90°	Para	A1035 ^c	12.2 12.3	12.2	11760	34	1
192	8-12-90-5#3vr-i-2.5-2-10	A B	90°	Perp	A1035 ^c	10.3 10.2	10.2	11800	38	1
193	8-12-90-4#3vr-i-2.5-2-10	A B	90°	Perp	A1035 ^c	10.6 10.3	10.4	11850	39	1
194	8-15-90-5#3-i-2.5-2-6	A B	90°	Para	A1035 ^c	6.5 6.1	6.3	15800	60	1
195	8-15-90-5#3-i-2.5-2-10	A B	90°	Para	A1035 ^c	10.6 9.7	10.1	15800	60	1
196	8-5-90-5#3-i-3.5-2-15	A B	90°	Para	A1035 ^b	15.8 15.8	15.8	4850	7	1
197	8-5-90-5#3-i-3.5-2-13	A B	90°	Para	A1035 ^b	13.3 13.0	13.1	5570	12	1
198	8-5-90-5#3-i-3.5-2-12(1)	A B	90°	Para	A1035 ^c	12.8 12.3	12.5	5090	7	1
199	8-5-90-5#3-i-3.5-2-12	A B	90°	Para	A1035 ^c	12.5 11.8	12.1	6440	9	1
200	8-8-90-5#3-i-3.5-2-8	A B	90°	Para	A1035 ^b	8.0 8.0	8.0	7910	15	1
201	8-12-90-5#3-i-3.5-2-9*	A B	90°	Para	A1035 ^b	9.0 9.0	9.0	11160	77	1
202	(2@5) 8-5-180-5#3-i-2.5-2-10 [‡]	A B	180°	Para	A615	10.0 10.3	10.1	5540	17	1
203	8-12-180-5#3-i-2.5-2-10	A B	180°	Para	A1035 ^c	9.9 9.6	9.8	11800	38	1
204	8-12-180-5#3vr-i-2.5-2-10	A B	180°	Perp	A1035 ^c	11.1 10.5	10.8	11800	38	1
205	8-12-180-4#3vr-i-2.5-2-10	A B	180°	Perp	A1035 ^c	10.5 10.0	10.3	11850	39	1
206	8-15-180-5#3-i-2.5-2-9.5	A B	180°	Para	A1035 ^c	9.6 9.8	9.7	15550	87	1
207	8-5-90-4#4s-i-2.5-2-15	A B	90°	Para	A1035 ^b	15.6 15.6	15.6	4810	6	1

[‡] Specimen contained A1035 Grade 120 for column longitudinal steel

^a Heat 1, ^b Heat 2, ^c Heat 3 as described in Table 2.3

Table B.2 Cont. Comprehensive test results and data for No. 8 specimens with two hooks

	Hook	R_r	b in.	h in.	h_{cl} in.	h_c in.	c_{so} in.	$c_{so,avg}$ in.	c_{th} in.	c_h in.	N_h	Axial Load kips	Long. Reinf. Layout ^o
183	A B	0.073	10.9	12.0	10.5	8.375	2.3 2.4	2.3	2.1 2.5	4.3	2	30	A2
184	A B	0.078	16.1	10.0	10.5	8.375	2.9 2.8	2.8	2.8 2.8	8.5	2	30	A2
185	A B	0.073	17.8	11.0	10.5	8.375	2.8 3.3	3.0	2.4 2.0	9.8	2	30	A2
186	A B	0.073	17.3	18.0	10.5	8.375	2.5 2.8	2.6	9.0 8.8	10.0	2	30	A7
187	A B	0.073	9.0	18.0	10.5	8.375	2.5 2.5	2.5	8.8 8.5	2.0	2	30	A7
188	A B	0.073	10.3	18.0	10.5	8.375	2.5 2.5	2.5	9.1 8.9	3.3	2	30	A7
189	A B	0.078	16.6	11.5	10.5	8.375	2.5 2.6	2.6	2.5 2.5	9.5	2	30	A2
190	A B	0.073	16.8	12.2	10.5	8.375	2.6 2.3	2.4	3.2 2.3	9.9	2	30	A2
191	A B	0.073	16.9	14.2	10.5	8.375	2.4 2.5	2.4	2.0 1.9	10.0	2	30	A2
192	A B	0.073	16.6	11.9	10.5	8.375	2.5 2.4	2.4	1.7 1.7	9.8	2	30	A2
193	A B	0.073	16.0	12.4	10.5	8.375	2.5 2.5	2.5	1.8 2.1	9.0	2	30	A2
194	A B	0.073	17.0	8.3	10.5	8.375	2.6 2.6	2.6	1.8 2.2	9.8	2	30	A11
195	A B	0.073	16.7	12.1	10.5	8.375	2.4 2.4	2.4	1.6 2.4	9.9	2	30	A11
196	A B	0.078	19.3	17.0	10.5	8.375	3.6 3.5	3.5	1.3 1.3	10.3	2	30	A2
197	A B	0.078	19.3	15.4	10.5	8.375	3.4 3.5	3.4	2.1 2.4	10.4	2	30	A2
198	A B	0.073	18.7	14.3	10.5	8.375	3.5 3.4	3.5	1.6 2.1	9.8	2	30	A2
199	A B	0.073	18.6	14.2	10.5	8.375	3.4 3.5	3.4	1.7 2.4	9.8	2	30	A2
200	A B	0.078	18.0	10.0	10.5	8.375	3.5 3.6	3.6	2.0 2.0	8.9	2	30	A2
201	A B	0.078	18.1	11.5	10.5	8.375	3.3 3.4	3.3	2.5 2.5	9.5	2	30	A2
202	A B	0.073	11.0	12.0	10.5	8.375	2.5 2.5	2.5	2.0 1.8	4.0	2	30	A10
203	A B	0.073	16.9	12.2	10.5	8.375	2.3 2.8	2.5	2.3 2.6	9.9	2	30	A2
204	A B	0.073	16.8	12.4	10.5	8.375	2.5 2.5	2.5	1.3 1.9	9.8	2	30	A2
205	A B	0.073	17.0	12.3	10.5	8.375	2.8 2.5	2.6	1.8 2.3	9.8	2	30	A2
206	A B	0.073	17.3	11.7	10.5	8.375	2.5 2.8	2.6	2.1 1.9	10.0	2	30	A10
207	A B	0.078	17.0	17.3	10.5	8.375	3.0 2.9	2.9	1.6 1.6	9.1	2	30	A2

^o Longitudinal column configurations shown in Appendix A, Figures A1 – A16

Table B.2 Cont. Comprehensive test results and data for No. 8 specimens with two hooks

	Hook	T_{max} lb	T_{ind} lb	T_{total} lb	T lb	T_h lb	T/T_h	$f_{su,max}$ psi	f_{su} psi	$f_{s,ACI}$ psi	Joint shear at failure/ $\sqrt{f_{cm}}$
183	A	59715	59715	111921	55960	59824	0.94	75589	70836	59957	7.5
	B	52232	52205					66116			
184	A	56006	49326	100532	50266	53859	0.93	70893	63628	58938	4.1
	B	51206	51206					64818			
185	A	64834	64834	128795	64397	61438	1.05	82068	81516	69089	4.6
	B	64027	63961					81047			
186	A	61960	61894	126597	63298	63120	1.00	78431	80125	71539	2.8
	B	65209	64703					82543			
187	A	56456	56420	117585	58792	63977	0.92	71463	74421	72200	5.1
	B	61169	61165					77430			
188	A	55664	55603	114911	57455	61977	0.93	70461	72728	69312	4.4
	B	59345	59307					75120			
189	A	66512	66512	129507	64753	67620	0.96	84193	81966	84890	3.9
	B	63119	62994					79897			
190	A	66000	64479	129061	64530	71117	0.91	83544	81684	91533	3.5
	B	64599	64582					81771			
191	A	90544	88954	175422	87711	88168	0.99	114613	111027	118308	4.1
	B	86469	86469					109454			
192	A	59428	59428	120439	60219	67059	0.90	75225	76227	99111	3.4
	B	64145	61011					81196			
193	A	80288	59214	118481	59241	66818	0.89	101630	74988	81157	3.3
	B	59267	59267					75021			
194	A	48315	48315	96998	48499	55384	0.88	61158	61391	70845	3.3
	B	48683	48683					61624			
195	A	111610	89783	180007	90003	80498	1.12	141278	113928	113633	4.3
	B	90223	90223					114207			
196	A	81187	81187	160681	80341	89047	0.90	102768	101697	97934	4.3
	B	87144	79494					110309			
197	A	89620	78290	154137	77069	78783	0.98	113443	97555	87460	4.2
	B	75971	75847					96166			
198	A	78862	78813	152863	76431	74137	1.03	99825	96749	79625	4.9
	B	75869	74050					96037			
199	A	79156	79156	158301	79150	76237	1.04	100198	100190	86877	4.5
	B	79258	79145					100327			
200	A	55391	55391	111619	55810	57384	0.97	70116	70645	63527	4.2
	B	56240	56228					71190			
201	A	68822	68822	135663	67831	67620	1.00	87116	85863	84890	3.7
	B	82227	66841					104084			
202	A	58132	58132	133288	66644	63791	1.04	73585	84359	67287	8.2
	B	75155	75155					95134			
203	A	63041	63041	128214	64107	73027	0.88	79798	81148	94564	3.5
	B	81419	65173					103062			
204	A	67538	67538	135560	67780	70708	0.96	85491	85798	104869	3.6
	B	68023	68023					86105			
205	A	69654	69654	138377	69188	65665	1.05	88170	87580	79699	3.7
	B	68753	68723					87030			
206	A	85951	85951	171901	85951	77095	1.11	108798	108798	107512	4.1
	B	85951	85951					108798			
207	A	93337	93337	187306	93653	92056	1.02	118148	118548	77404	5.6
	B	107709	93969					136340			

Table B.2 Cont. Comprehensive test results and data for No. 8 specimens with two hooks

	Hook	Slip at Failure in.	Failure Type	f_{yt} ksi	d_{tr} in.	$A_{v,l}$ in. ²	N_{tr}	s_{tr} in.	A_{cti} in. ²	N_{cti}	s_{cti} in.	d_s in.	s_s in.	d_{cto} in.	N_{cto}	A_s in. ²	f_{ys} ksi
183	A B	0.12 0.29	F F	60	0.375	0.11	5	3.00	-	-	-	0.38	4.00	-	-	3.16	120
184	A B	0.3 .375 (.092)	F F	60	0.375	0.11	5	3.00	1.20	6	3.0	0.50	1.50	-	-	3.16	60
185	A B	0.047 0	F F	60	0.375	0.11	5	3.00	-	-	-	0.38	4.00	-	-	3.16	120
186	A B	0.05 0	F F	60	0.375	0.11	5	3.00	-	-	-	0.38	4.00	-	-	4.74	120
187	A B	0.082 -	F F	60	0.375	0.11	5	3.00	-	-	-	0.38	4.00	-	-	4.74	60
188	A B	0.117 0	F F	60	0.375	0.11	5	3.00	-	-	-	0.38	4.00	-	-	4.74	60
189	A B	0.224 0.252	F/S F/S	60	0.375	0.11	5	3.00	0.88	8	4.0	0.50	4.00	0.375	2	3.16	60
190	A B	0.44 0.547	F/S S/F	60	0.375	0.11	5	3.00	-	-	-	0.50	1.75	-	-	3.16	60
191	A B	- -	F/S S/F	60	0.375	0.11	5	3.00	-	-	-	0.38	4.00	-	-	3.16	120
192	A B	0.236 0.246	F F	60	0.375	0.11	5	1.75	-	-	-	0.50	1.75	-	-	3.16	60
193	A B	0.123 0.101	F/S F	60	0.375	0.11	4	2.25	-	-	-	0.50	1.75	-	-	3.16	60
194	A B	- -	F F	60	0.375	0.11	5	3.00	-	-	-	0.38	2.75	-	-	6.32	60
195	A B	- 0.407	F/S F/S	60	0.375	0.11	5	3.00	-	-	-	0.38	3.00	-	-	6.32	60
196	A B	.214(.026) -	S/F S/F	60	0.375	0.11	5	3.00	0.55	5	3.0	0.38	3.50	0.375	2	3.16	60
197	A B	- -	S S/F	60	0.375	0.11	5	3.00	1.00	5	3.0	0.50	3.00	0.375	1	3.16	60
198	A B	- -	S/F S	60	0.375	0.11	5	3.00	0.55	5	3.0	0.38	3.50	0.5	2	3.16	60
199	A B	- 0.162	F F/S	60	0.375	0.11	5	3.00	0.55	5	3.0	0.38	3.50	0.5	2	3.16	60
200	A B	- -	F F	60	0.375	0.11	5	3.00	1.20	6	3.0	0.50	1.50	-	-	3.16	60
201	A B	- 0.415	F/S F/S	60	0.375	0.11	5	3.00	0.88	8	4.0	0.50	4.00	0.375	2	3.16	60
202	A B	- 0.111	F F	60	0.375	0.11	5	3.00	-	-	-	0.50	4.00	-	-	6.32	120
203	A B	- 0.339	F/S F	60	0.375	0.11	5	3.00	-	-	-	0.50	1.75	-	-	3.16	60
204	A B	- 0.321	F F	60	0.375	0.11	5	1.75	-	-	-	0.50	1.75	-	-	3.16	60
205	A B	- -	F F	60	0.375	0.11	4	2.25	-	-	-	0.50	1.75	-	-	3.16	60
206	A B	- -	S F/S	60	0.375	0.11	5	3.00	-	-	-	0.50	4.00	-	-	6.32	60
207	A B	0.21 -	S/F F/S	60	0.5	0.20	4	4.00	0.88	8	4.0	0.38	3.50	0.375	2	3.16	60

Table B.2 Cont. Comprehensive test results and data for No. 8 specimens with two hooks

	Specimen	Hook	Bend Angle	Trans. Reinf. Orient.	Hook Bar Type	l_{eh} in.	$l_{eh,avg}$ in.	f'_c psi	Age days	d_b in.
208	8-5-90-4#4s-i-2.5-2-12(1)	A B	90°	Para	A1035 ^c	12.3 12.5	12.4	5180	8	1
209	8-5-90-4#4s-i-2.5-2-12	A B	90°	Para	A1035 ^c	12.0 12.6	12.3	6210	8	1
210	8-5-90-4#4s-i-3.5-2-15	A B	90°	Para	A1035 ^b	15.5 15.1	15.3	4810	6	1
211	8-5-90-4#4s-i-3.5-2-12(1)	A B	90°	Para	A1035 ^c	12.0 11.9	11.9	5910	14	1
212	8-5-90-4#4s-i-3.5-2-12	A B	90°	Para	A1035 ^c	12.0 12.5	12.3	5960	7	1

^a Heat 1, ^b Heat 2, ^c Heat 3 as described in Table 2.3

Table B.2 Cont. Comprehensive test results and data for No. 8 specimens with two hooks

	Hook	R_r	b in.	h in.	h_{cl} in.	h_c in.	c_{so} in.	$c_{so,avg}$ in.	c_{th} in.	c_h in.	N_h	Axial Load kips	Long. Reinf. Layout ^o
208	A B	0.073	17.1	14.4	10.5	8.375	2.5 2.6	2.6	2.1 1.9	10.0	2	30	A2
209	A B	0.073	16.6	14.3	10.5	8.375	2.6 2.5	2.6	2.3 1.6	9.5	2	30	A2
210	A B	0.078	19.6	17.3	10.5	8.375	4.1 4.0	4.1	1.8 2.1	9.5	2	30	A2
211	A B	0.073	19.0	14.3	10.5	8.375	3.8 3.5	3.6	2.3 2.4	9.8	2	30	A2
212	A B	0.073	18.3	14.4	10.5	8.375	3.8 3.5	3.6	2.4 1.9	9.0	2	30	A2

^o Longitudinal column configurations shown in Appendix A, Figures A1 – A16

Table B.2 Cont. Comprehensive test results and data for No. 8 specimens with two hooks

	Hook	T_{max} lb	T_{ind} lb	T_{total} lb	T lb	T_h lb	T/T_h	$f_{su,max}$ psi	f_{su} psi	$f_{s,ACI}$ psi	Joint shear at failure/ $\sqrt{f'_{cm}}$
208	A B	100177 90092	91540 90092	181632	90816	77607	1.17	126806 114041	114957	63618	6.2
209	A B	116352 99672	99838 99672	199509	99755	80367	1.24	147281 126167	126272	69305	6.5
210	A B	105974 90156	91613 90118	181730	90865	90541	1.00	134144 114121	115019	75856	4.7
211	A B	115165 92876	113609 77301	190910	95455	77612	1.23	145779 117565	120829	65551	5.6
212	A B	103861 96919	99392 96919	196312	98156	79340	1.24	131470 122683	124248	67551	5.9

Table B.2 Cont. Comprehensive test results and data for No. 8 specimens with two hooks

	Hook	Slip at Failure in.	Failure Type	f_{yt} ksi	d_{tr} in.	$A_{tr,t}$ in. ²	N_{tr}	s_{tr} in.	A_{cti} in. ²	N_{cti}	s_{cti} in.	d_s in.	s_s in.	d_{cto} in.	N_{cto}	A_s in. ²	f_{ys} ksi
208	A B	- -	F/S F/S	60	0.5	0.20	4	4.00	1.60	8	4.0	0.50	3.50	0.5	1	3.16	60
209	A B		F/S S/F	60	0.5	0.20	4	4.00	1.60	8	4.0	0.50	3.50	0.5	1	3.16	60
210	A B	- -	F/S S/F	60	0.5	0.20	4	4.00	0.88	8	4.0	0.38	3.50	0.375	2	3.16	60
211	A B	- -	S F/S	60	0.5	0.20	4	4.00	1.60	8	4.0	0.50	3.50	0.5	1	3.16	60
212	A B		S/F F/S	60	0.5	0.20	4	4.00	1.60	8	4.0	0.50	3.50	0.5	1	3.16	60

Table B.3 Comprehensive test results and data for No. 11 specimens with two hooks

	Specimen	Hook	Bend Angle	Trans. Reinf. Orient.	Hook Bar Type	ℓ_{eh} in.	$\ell_{eh,avg}$ in.	f'_c psi	Age days	d_b in.
213	11-8-90-0-o-2.5-2-25	A B	90°	Para	A1035	25.3 25.1	25.2	9460	9	1.41
214	11-8-90-0-o-2.5-2-17	A B	90°	Para	A1035	16.8 16.4	16.6	9460	9	1.41
215	11-12-90-0-o-2.5-2-17	A B	90°	Para	A1035	17.1 16.6	16.9	11800	36	1.41
216	11-12-180-0-o-2.5-2-17	A B	180°	Para	A1035	16.9 17.3	17.1	11800	36	1.41
217	11-5-90-0-i-2.5-2-14	A B	90°	Para	A615	13.5 15.3	14.4	4910	13	1.41
218	11-5-90-0-i-2.5-2-26	A B	90°	Para	A1035	26.0 26.0	26.0	5360	6	1.41
219	(2@5.35) 11-5-90-0-i-2.5-13-13	A B	90°	Para	A615	14.0 13.9	13.9	5330	11	1.41
220	11-8-90-0-i-2.5-2-17	A B	90°	Para	A1035	17.3 18.0	17.6	9460	9	1.41
221	11-8-90-0-i-2.5-2-21	A B	90°	Para	A1035	20.0 21.1	20.6	7870	6	1.41
222	11-8-90-0-i-2.5-2-17	A B	90°	Para	A1035	16.3 18.1	17.2	8520	7	1.41
223	11-12-90-0-i-2.5-2-17	A B	90°	Para	A1035	16.1 16.9	16.5	11880	35	1.41
224	11-12-90-0-i-2.5-2-17.5	A B	90°	Para	A1035	17.6 17.8	17.7	13330	31	1.41
225	11-12-90-0-i-2.5-2-25	A B	90°	Para	A1035	24.9 24.4	24.6	13330	34	1.41
226	11-15-90-0-i-2.5-2-24	A B	90°	Para	A1035	24.0 24.8	24.4	16180	62	1.41
227	11-15-90-0-i-2.5-2-11	A B	90°	Para	A1035	12.1 11.5	11.8	16180	63	1.41
228	11-15-90-0-i-2.5-2-10‡	A B	90°	Para	A615	9.5 9.5	9.5	14050	76	1.41
229	11-15-90-0-i-2.5-2-15‡	A B	90°	Para	A1035	14.0 14.0	14.0	14050	77	1.41
230	11-5-90-0-i-3.5-2-17	A B	90°	Para	A1035	18.1 17.6	17.9	5600	24	1.41
231	11-5-90-0-i-3.5-2-14	A B	90°	Para	A615	14.8 15.3	15.0	4910	13	1.41
232	11-5-90-0-i-3.5-2-26	A B	90°	Para	A1035	26.3 25.8	26.0	5960	8	1.41
233	11-8-180-0-i-2.5-2-21	A B	180°	Para	A1035	21.3 20.9	21.1	7870	6	1.41
234	11-8-180-0-i-2.5-2-17	A B	180°	Para	A1035	17.8 18.0	17.9	8520	7	1.41
235	11-12-180-0-i-2.5-2-17	A B	180°	Para	A1035	16.6 16.6	16.6	11880	35	1.41
236	11-5-90-1#4-i-2.5-2-17	A B	90°	Para	A1035	17.8 17.6	17.7	5790	25	1.41
237	11-5-90-1#4-i-3.5-2-17	A B	90°	Para	A1035	17.8 17.8	17.8	5790	25	1.41
238	11-5-90-2#3-i-2.5-2-17	A B	90°	Para	A1035	17.4 17.8	17.6	5600	24	1.41

‡ Specimen contained A1035 Grade 120 for column longitudinal steel

Table B.3 Cont. Comprehensive test results and data for No. 11 specimens with two hooks

	Hook	R_r	b in.	h in.	h_{cl} in.	h_c in.	c_{so} in.	$c_{so,avg}$ in.	c_{th} in.	c_h in.	N_h	Axial Load kips	Long. Reinf. Layout ^o
213	A B	0.085	21.9	27.4	19.5	8.375	2.6 2.9	2.8	2.2 2.3	13.6	2	169	A16
214	A B	0.085	21.4	19.3	19.5	8.375	2.5 2.4	2.4	2.6 2.9	13.8	2	116	A16
215	A B	0.085	21.6	19.3	19.5	8.375	2.5 2.5	2.5	2.2 2.7	13.8	2	117	A7
216	A B	0.085	21.3	19.2	19.5	8.375	2.5 2.6	2.5	2.3 1.9	13.4	2	114	A7
217	A B	0.069	21.6	16.0	19.5	8.375	2.8 2.8	2.8	2.5 0.8	13.3	2	97	A7
218	A B	0.085	21.5	28.1	19.5	8.375	2.5 2.9	2.7	2.1 2.1	13.3	2	169	A12
219	A B	0.085	14.1	26.0	19.5	8.375	2.6 2.6	2.6	12.0 12.1	6.2	2	103	A14
220	A B	0.085	21.2	19.3	19.5	8.375	2.5 2.5	2.5	2.0 1.3	13.4	2	114	A16
221	A B	0.085	21.1	23.4	19.5	8.375	2.5 2.8	2.6	3.4 2.3	13.0	2	138	A13
222	A B	0.085	21.3	19.3	19.5	8.375	2.5 2.5	2.5	3.0 1.1	13.5	2	115	A8
223	A B	0.085	21.2	19.3	19.5	8.375	2.5 2.6	2.6	3.1 2.4	13.3	2	114	A13
224	A B	0.085	22.8	19.8	19.5	8.375	3.8 2.5	3.1	2.1 2.0	13.8	2	126	A7
225	A B	0.085	20.9	27.3	19.5	8.375	2.5 2.5	2.5	2.4 2.9	13.1	2	160	A12
226	A B	0.085	21.3	26.0	19.5	8.375	2.5 2.5	2.5	2.0 1.3	13.5	2	155	A11
227	A B	0.085	20.9	13.1	19.5	8.375	2.4 2.8	2.6	1.0 1.6	13.0	2	77	A2
228	A B	0.085	21.9	12.0	19.5	8.375	2.8 2.7	2.7	2.5 2.5	13.6	2	74	A15
229	A B	0.085	21.4	17.0	19.5	8.375	2.8 2.8	2.8	3.0 3.0	13.0	2	102	A15
230	A B	0.085	23.8	20.0	19.5	8.375	4.0 3.9	3.9	1.8 2.5	13.1	2	133	A7
231	A B	0.069	23.7	16.3	19.5	8.375	3.8 3.9	3.8	1.5 1.0	13.3	2	108	A7
232	A B	0.085	23.8	28.4	19.5	8.375	3.8 3.8	3.8	2.1 2.6	13.5	2	189	A12
233	A B	0.085	21.1	23.1	19.5	8.375	2.9 2.4	2.7	1.8 2.2	13.0	2	137	A13
234	A B	0.085	21.4	19.1	19.5	8.375	2.4 2.5	2.4	1.4 1.1	13.8	2	115	A8
235	A B	0.085	21.6	19.2	19.5	8.375	3.0 2.5	2.8	2.5 2.5	13.3	2	116	A13
236	A B	0.085	21.4	19.6	19.5	8.375	2.8 2.8	2.8	1.8 2.0	13.1	2	117	A7
237	A B	0.085	23.6	19.5	19.5	8.375	3.8 3.9	3.8	1.8 1.8	13.1	2	129	A7
238	A B	0.085	21.3	19.6	19.5	8.375	2.5 2.6	2.6	2.3 1.8	13.4	2	117	A7

^o Longitudinal column configurations shown in Appendix A, Figures A1 – A16

Table B.3 Cont. Comprehensive test results and data for No. 11 specimens with two hooks

	Hook	T_{max} lb	T_{ind} lb	T_{total} lb	T lb	T_h lb	T/T_h	$f_{su,max}$ psi	f_{su} psi	$f_{s,ACI}$ psi	Joint shear at failure/$\sqrt{f_{cm}}$
213	A	194500	178670	349530	174765	173772	1.01	124679	112029	124103	4.1
	B	170700	170860					109423			
214	A	121403	108779	214417	107209	111429	0.96	77822	68723	81606	3.7
	B	105721	105638					67770			
215	A	123725	105010	210804	105402	121183	0.87	79311	67565	92862	3.2
	B	105794	105794					67817			
216	A	83343	83343	166986	83493	122610	0.68	53425	53521	93894	2.6
	B	90122	83644					57770			
217	A	67249	67249	133180	66590	79286	0.84	43108	42686	51027	3.8
	B	81430	65931					52199			
218	A	165682	150653	297454	148727	152421	0.98	106206	95338	96429	4.6
	B	146801	146801					94103			
219	A	58206	58206	121186	60593	78578	0.77	37311	38842	51547	3.1
	B	63035	62981					40407			
220	A	131998	131969	264111	132055	119020	1.11	84614	84651	86842	4.6
	B	141233	132141					90534			
221	A	127061	127061	250252	125126	132865	0.94	81449	80209	92409	3.9
	B	147904	123191					94810			
222	A	105626	105537	209557	104779	112427	0.93	67709	67166	80368	3.8
	B	115172	104020					73828			
223	A	148361	148361	268741	134371	118562	1.13	95103	86135	91106	4.1
	B	120380	120380					77167			
224	A	125648	125648	249245	124622	131960	0.94	80544	79886	103451	3.3
	B	123622	123597					79245			
225	A	205050	201395	399486	199743	187403	1.07	131443	128040	144027	4.2
	B	198110	198091					126994			
226	A	212601	212601	426530	213265	196102	1.09	136283	136708	157068	4.2
	B	231323	213928					148284			
227	A	48563	48563	96252	48126	90992	0.53	31130	30850	76117	1.9
	B	47717	47689					30588			
228	A	52097	52097	102962	51481	69331	0.74	33395	33001	57045	2.3
	B	50882	50866					32617			
229	A	93327	93327	184335	92168	104578	0.88	59825	59082	84066	2.9
	B	91008	91008					58339			
230	A	105772	105772	216244	108122	103770	1.04	67803	69309	67763	4.2
	B	117570	110472					75366			
231	A	82601	70046	139027	69514	82944	0.84	52949	44560	53246	3.5
	B	68982	68982					44219			
232	A	198346	183026	364508	182254	157184	1.16	127145	116829	101683	4.8
	B	181661	181481					116449			
233	A	137773	129406	256246	128123	136292	0.94	88316	82130	94656	4.1
	B	126839	126839					81307			
234	A	101710	101710	200907	100453	117199	0.86	65199	64393	83583	3.6
	B	121269	99197					77737			
235	A	106726	106726	214921	107461	119514	0.90	68414	68885	91796	3.3
	B	108195	108195					69356			
236	A	99443	99403	202995	101498	115679	0.88	63746	65063	68180	4.4
	B	119681	103592					76718			
237	A	105692	103693	212540	106270	116068	0.92	67751	68122	68421	4.2
	B	108846	108846					69773			
238	A	108406	98172	201390	100695	108250	0.93	69491	64548	66578	4.4
	B	103234	103218					66176			

Table B.3 Cont. Comprehensive test results and data for No. 11 specimens with two hooks

	Hook	Slip at Failure in.	Failure Type	f_{yt} ksi	d_{tr} in.	$A_{tr,l}$ in. ²	N_{tr}	s_{tr} in.	A_{cti} in. ²	N_{cti}	s_{cti} in.	d_s in.	s_s in.	d_{cto} in.	N_{cto}	A_s in. ²	f_{ys} ksi
213	A B	- -	S S	60	-	-	-	-	-	-	-	0.50	6.0	-	-	9.48	60
214	A B	- -	S/F S/TK	60	-	-	-	-	-	-	-	0.50	6.0	-	-	9.48	60
215	A B	0.143 -	F/TK F/TK	60	-	-	-	-	-	-	-	0.50	3.5	-	-	4.74	60
216	A B	- -	S/F S	60	-	-	-	-	-	-	-	0.50	3.5	-	-	4.74	60
217	A B	0.139 -	F/S S	60	-	-	-	-	2.4	12	4.0	0.50	4.0	0.375	2	4.74	60
218	A B	- -	F/S F/S/TK	60	-	-	-	-	1.86	6	4.0	0.50	4.0	0.375	1	6.32	60
219	A B	0.2 -	F F	60	-	-	-	-	-	-	-	0.50	7.0	-	-	7.90	60
220	A B	- -	F/TK F/TK	60	-	-	-	-	-	-	-	0.50	6.0	-	-	9.48	60
221	A B	- -	F/TK F	60	-	-	-	-	-	-	-	0.50	6.0	-	-	9.40	60
222	A B	- -	S F	60	-	-	-	-	-	-	-	0.50	8.0	-	-	6.28	60
223	A B	- -	S S/F	60	-	-	-	-	-	-	-	0.50	6.0	-	-	9.40	60
224	A B	- 0.25	S/TK S	60	-	-	-	-	2.4	12	4.0	0.50	4.0	-	-	4.74	60
225	A B	- -	S S	60	-	-	-	-	3.6	18	4.0	0.50	4.0	0.5	1	6.32	60
226	A B	- -	S/TK S/TK	60	-	-	-	-	-	-	-	0.50	3.5	-	-	6.32	60
227	A B	- 0.252	F/TK F	60	-	-	-	-	-	-	-	0.50	3.0	-	-	3.16	60
228	A B	- -	F F	60	-	-	-	-	-	-	-	0.50	4.5	-	-	6.94	120
229	A B	- -	S S	60	-	-	-	-	-	-	-	0.50	4.5	-	-	6.94	120
230	A B	0.187 -	S/TK S	60	-	-	-	-	2.4	12	4.0	0.50	4.0	0.375	2	4.74	60
231	A B	- -	F/S F/S/TK	60	-	-	-	-	2.4	12	4.0	0.50	4.0	0.375	2	4.74	60
232	A B	- -	S/F F/S	60	-	-	-	-	1.86	6	4.0	0.50	4.0	0.375	1	6.32	60
233	A B	- -	F F/S	60	-	-	-	-	-	-	-	0.50	6.0	-	-	9.40	60
234	A B	- -	F F	60	-	-	-	-	-	-	-	0.50	8.0	-	-	6.28	60
235	A B	0.156 -	S/F S	60	-	-	-	-	-	-	-	0.50	6.0	-	-	9.40	60
236	A B	- -	S/F F/S	60	0.5	0.20	1	8.75	2.2	11	4.0	0.50	4.0	0.375	2	4.74	60
237	A B	- -	S S/F/TK	60	0.5	0.20	1	8.75	2.2	11	4.0	0.50	4.0	0.375	2	4.74	60
238	A B	- -	S/F S/F	60	0.375	0.11	2	8.00	2	10	4.0	0.50	4.0	0.375	2	4.74	60

Table B.3 Cont. Comprehensive test results and data for No. 11 specimens with two hooks

	Specimen	Hook	Bend Angle	Trans. Reinf. Orient.	Hook Bar Type	l_{eh} in.	$l_{eh,avg}$ in.	f'_c psi	Age days	d_b in.
239	11-5-90-2#3-i-2.5-2-14	A B	90°	Para	A615	13.5 13.8	13.6	4910	13	1.41
240	(2@5.35) 11-5-90-2#3-i-2.5-13-13	A B	90°	Para	A615	13.9 13.8	13.8	5330	11	1.41
241	11-12-90-2#3-i-2.5-2-17.5	A B	90°	Para	A1035	18.0 17.5	17.8	13710	30	1.41
242	11-12-90-2#3-i-2.5-2-25	A B	90°	Para	A1035	25.0 24.5	24.8	13710	30	1.41
243	11-15-90-2#3-i-2.5-2-23	A B	90°	Para	A1035	23.5 23.5	23.5	16180	62	1.41
244	11-15-90-2#3-i-2.5-2-10.5	A B	90°	Para	A1035	11.8 10.5	11.1	16180	63	1.41
245	11-15-90-2#3-i-2.5-2-10 [‡]	A B	90°	Para	A615	10.0 10.0	10.0	14045	76	1.41
246	11-15-90-2#3-i-2.5-2-15 [‡]	A B	90°	Para	A1035	14.0 14.3	14.1	14045	80	1.41
247	11-5-90-2#3-i-3.5-2-17	A B	90°	Para	A1035	17.5 17.8	17.6	7070	28	1.41
248	11-5-90-2#3-i-3.5-2-14	A B	90°	Para	A615	14.5 13.4	13.9	4910	12	1.41
249	11-5-90-5#3-i-2.5-2-14	A B	90°	Para	A615	14.3 13.5	13.9	4910	12	1.41
250	11-5-90-5#3-i-3.5-2-14	A B	90°	Para	A615	14.6 14.5	14.6	4910	14	1.41
251	11-8-90-6#3-o-2.5-2-16	A B	90°	Para	A1035	15.9 16.5	16.2	9420	8	1.41
252	11-8-90-6#3-o-2.5-2-22	A B	90°	Para	A1035	21.5 22.3	21.9	9120	7	1.41
253	11-12-90-6#3-o-2.5-2-17	A B	90°	Para	A1035	15.6 17.3	16.4	11800	36	1.41
254	11-12-180-6#3-o-2.5-2-17	A B	180°	Para	A1035	16.6 16.4	16.5	11800	36	1.41
255	11-5-90-6#3-i-2.5-2-20	A B	90°	Para	A1035	19.5 19.0	19.3	5420	7	1.41
256	(2@5.35) 11-5-90-6#3-i-2.5-13-13	A B	90°	Para	A615	14.0 13.8	13.9	5280	12	1.41
257	(2@5.35) 11-5-90-6#3-i-2.5-18-18	A B	90°	Para	A1035	19.3 19.5	19.4	5280	12	1.41
258	11-8-90-6#3-i-2.5-2-16	A B	90°	Para	A1035	15.5 16.4	15.9	9120	7	1.41
259	11-8-90-6#3-i-2.5-2-22	A B	90°	Para	A1035	21.3 21.5	21.4	9420	8	1.41
260	11-8-90-6#3-i-2.5-2-22	A B	90°	Para	A1035	21.9 22.0	21.9	9420	8	1.41
261	11-8-90-6#3-i-2.5-2-15	A B	90°	Para	A1035	15.8 15.3	15.5	7500	5	1.41
262	11-8-90-6#3-i-2.5-2-19	A B	90°	Para	A1035	19.1 19.4	19.2	7500	5	1.41
263	11-12-90-6#3-i-2.5-2-17	A B	90°	Para	A1035	17.1 16.5	16.8	12370	37	1.41
264	11-12-90-6#3-i-2.5-2-16	A B	90°	Para	A1035	14.8 16.0	15.4	13710	31	1.41

Table B.3 Cont. Comprehensive test results and data for No. 11 specimens with two hooks

	Hook	R_r	b in.	h in.	h_{cl} in.	h_c in.	c_{so} in.	$c_{so,avg}$ in.	c_{th} in.	c_h in.	N_h	Axial Load kips	Long. Reinf. Layout ^o
239	A B	0.069	21.7	16.0	19.5	8.375	2.8 2.9	2.8	2.5 2.3	13.3	2	97	A7
240	A B	0.085	14.3	26.0	19.5	8.375	2.7 2.6	2.6	12.1 12.3	6.2	2	104	A14
241	A B	0.085	21.1	19.5	19.5	8.375	2.5 2.5	2.5	1.5 2.0	13.3	2	115	A7
242	A B	0.085	21.4	27.3	19.5	8.375	2.6 3.0	2.8	2.3 2.8	13.0	2	164	A12
243	A B	0.085	21.3	25.0	19.5	8.375	2.8 2.8	2.8	1.5 1.5	13.0	2	149	A11
244	A B	0.085	21.8	12.8	19.5	8.375	2.5 2.8	2.6	1.0 2.3	13.8	2	78	A2
245	A B	0.085	22.0	12.0	19.5	8.375	2.8 3.0	2.9	2.0 2.0	13.4	2	74	A15
246	A B	0.085	21.5	17.0	19.5	8.375	2.6 2.6	2.6	3.0 2.8	13.6	2	102	A15
247	A B	0.085	23.4	19.7	19.5	8.375	3.6 3.6	3.6	2.1 2.0	13.4	2	129	A7
248	A B	0.069	23.7	16.1	19.5	8.375	3.8 3.9	3.8	1.6 2.8	13.3	2	107	A7
249	A B	0.069	21.8	16.0	19.5	8.375	2.8 2.9	2.8	1.8 2.5	13.4	2	98	A7
250	A B	0.069	23.7	16.0	19.5	8.375	3.9 3.9	3.9	1.4 1.5	13.1	2	106	A7
251	A B	0.085	21.6	18.1	19.5	8.375	2.5 2.6	2.6	2.3 1.6	13.6	2	109	A16
252	A B	0.085	21.4	24.4	19.5	8.375	2.5 2.6	2.6	2.9 2.1	13.5	2	146	A16
253	A B	0.085	21.4	19.3	19.5	8.375	2.5 2.4	2.4	3.6 2.0	13.8	2	116	A7
254	A B	0.085	21.6	19.5	19.5	8.375	2.5 2.8	2.6	2.9 3.1	13.5	2	118	A7
255	A B	0.085	20.9	22.3	19.5	8.375	2.6 2.6	2.6	2.8 3.3	12.9	2	130	A7
256	A B	0.085	14.2	26.0	19.5	8.375	2.4 2.8	2.6	12.0 12.3	6.2	2	103	A14
257	A B	0.085	14.3	36.0	19.5	8.375	2.7 2.6	2.6	16.8 16.5	6.2	2	144	A14
258	A B	0.085	21.2	18.3	19.5	8.375	2.5 2.5	2.5	2.8 1.9	13.4	2	108	A16
259	A B	0.085	21.4	24.1	19.5	8.375	2.5 2.6	2.6	2.8 2.6	13.5	2	145	A11
260	A B	0.085	21.7	24.2	19.5	8.375	2.6 2.9	2.8	2.3 2.2	13.4	2	147	A16
261	A B	0.085	21.6	17.3	19.5	8.375	2.8 2.5	2.6	1.5 2.0	13.5	2	104	A13
262	A B	0.085	21.4	21.0	19.5	8.375	2.5 2.6	2.6	2.0 1.7	13.5	2	126	A13
263	A B	0.085	21.4	19.1	19.5	8.375	2.6 3.0	2.8	1.9 2.6	13.0	2	114	A13
264	A B	0.085	20.8	18.0	19.5	8.375	2.5 2.5	2.5	3.3 2.0	13.0	2	105	A7

^o Longitudinal column configurations shown in Appendix A, Figures A1 – A16

Table B.3 Cont. Comprehensive test results and data for No. 11 specimens with two hooks

	Hook	T_{max} lb	T_{ind} lb	T_{total} lb	T lb	T_h lb	T/T_h	$f_{su,max}$ psi	f_{su} psi	$f_{s,ACI}$ psi	Joint shear at failure/$\sqrt{f_{cm}}$
239	A B	77718 77214	77718 77127	154845	77422	81310	0.95	49819 49496	49630	48365	4.4
240	A B	68288 70143	68250 69997	138247	69123	84234	0.82	43774 44963	44310	51084	3.5
241	A B	133178 129868	132555 128223	260779	130389	139941	0.93	85371 83249	83583	105286	3.7
242	A B	210112 205996	210112 205996	416108	208054	196355	1.06	134687 132049	133368	146807	4.2
243	A B	232100 206900	212550 206600	419150	209575	195050	1.07	148782 132628	134343	151429	4.2
244	A B	50558 49575	50558 49547	100105	50053	91790	0.55	32409 31779	32085	71687	1.9
245	A B	64250 63631	64250 63631	127881	63940	79600	0.80	41186 40789	40987	60036	2.8
246	A B	115577 114801	115577 114801	230377	115189	111959	1.03	74088 73590	73839	84801	3.6
247	A B	107807 111480	107807 111480	219287	109644	115784	0.95	69107 71462	70284	75074	3.9
248	A B	92719 81848	82732 81817	164549	82275	83132	0.99	59435 52467	52740	49474	4.2
249	A B	105597 94115	96267 94072	190339	95170	96880	0.98	67690 60330	61006	49252	5.3
250	A B	101315 94663	101315 94663	195979	97989	100897	0.97	64946 60682	62814	51693	5.1
251	A B	138900 134714	138793 134714	273507	136753	129138	1.06	89038 86355	87662	99487	4.9
252	A B	186100 170498	170000 170498	340498	170249	168582	1.01	119295 109294	109134	132284	4.7
253	A B	116430 147268	116390 115367	231757	115878	138370	0.84	74635 94403	74281	113068	3.5
254	A B	130005 113819	112424 113819	226243	113121	138845	0.81	83337 72961	72514	113498	3.4
255	A B	153119 134977	137617 134927	272543	136272	131706	1.03	98153 86524	87354	89741	5.5
256	A B	83757 95951	83556 95940	179496	89748	98506	0.91	53691 61507	57531	63843	4.6
257	A B	118507 128624	116107 127103	243210	121605	131625	0.92	75966 82451	77952	89150	4.5
258	A B	147508 129692	136385 129586	265971	132986	126362	1.05	94556 83136	85247	96379	4.9
259	A B	204260 183175	186246 182892	369138	184569	166360	1.11	130936 117420	118314	131369	5.1
260	A B	197739 191344	190740 191344	382084	191042	170431	1.12	126756 122656	122463	134827	5.2
261	A B	142278 108021	108602 108021	216623	108312	117618	0.92	91204 69245	69431	85001	4.6
262	A B	182735 146093	144766 146093	290860	145430	142479	1.02	117138 93650	93224	105395	5.1
263	A B	179693 162285	161019 162277	323295	161648	142884	1.13	115188 104029	103620	118408	4.9
264	A B	115139 127542	115089 115306	230394	115197	135193	0.85	73807 81758	73844	113998	3.6

Table B.3 Cont. Comprehensive test results and data for No. 11 specimens with two hooks

	Hook	Slip at Failure in.	Failure Type	f_{yt} ksi	d_{tr} in.	$A_{tr,l}$ in. ²	N_{tr}	s_{tr} in.	A_{cti} in. ²	N_{cti}	s_{cti} in.	d_s in.	s_s in.	d_{cto} in.	N_{cto}	A_s in. ²	f_{ys} ksi
239	A B	0.206 -	F/S S	60	0.375	0.11	2	8.00	2.4	12	4.0	0.50	4.0	0.375	2	4.74	60
240	A B	- -	F F	60	0.38	0.11	2	8.00	-	-	-	0.50	7.0	-	-	7.90	60
241	A B	- -	S S	60	0.375	0.11	2	12.00	2.4	12	4.0	0.50	4.0	-	-	4.74	60
242	A B	- -	BY BY	60	0.375	0.11	2	12.00	3.2	16	4.0	0.50	4.0	0.5	1	6.32	60
243	A B	- -	S S/F	60	0.375	0.11	2	8.00	-	-	-	0.50	3.0	-	-	6.32	60
244	A B	0.249 -	F F/S	60	0.375	0.11	2	8.00	-	-	-	0.50	2.8	-	-	3.16	60
245	A B	- -	F F	60	0.38	0.11	2	8.00	-	-	-	0.50	4.5	-	-	6.94	120
246	A B	- -	F/S F/S	60	0.375	0.11	2	8.00	-	-	-	0.50	4.5	-	-	6.94	120
247	A B	- -	S/F/TK S	60	0.375	0.11	2	8.00	2	10	4.0	0.50	4.0	0.375	2	4.74	60
248	A B	- -	F/S S/F/TK	60	0.375	0.11	2	8.00	2.4	12	4.0	0.50	4.0	0.375	2	4.74	60
249	A B	0.397 0.375	S/F S/F	60	0.375	0.11	5	4.38	2.4	12	4.0	0.50	4.0	0.375	2	4.74	60
250	A B	- -	F/S S/F	60	0.375	0.11	5	4.38	2.4	12	4.0	0.50	4.0	0.375	2	4.74	60
251	A B	- -	S/F S/F	60	0.375	0.11	6	4.00	-	-	-	0.50	6.0	-	-	9.48	60
252	A B	- -	S S/F	60	0.375	0.11	6	4.00	-	-	-	0.50	6.0	-	-	9.48	60
253	A B	- -	F/S S/F	60	0.375	0.11	6	4.00	-	-	-	0.50	3.5	-	-	4.74	60
254	A B	- 0.112	S F/S	60	0.375	0.11	6	4.00	-	-	-	0.50	3.5	-	-	4.74	60
255	A B	0.274 -	F/S F/S	60	0.375	0.11	6	4.00	1.2	6	4.0	0.50	4.0	0.375	2	4.74	60
256	A B	- -	F F	60	0.375	0.11	6	4.00	-	-	-	0.50	7.0	-	-	7.90	60
257	A B	- -	F F	60	0.375	0.11	6	4.00	-	-	-	0.50	7.0	-	-	7.90	60
258	A B	- -	F/S F/S	60	0.375	0.11	6	4.00	-	-	-	0.50	6.0	-	-	9.48	60
259	A B	- -	* S	60	0.375	0.11	6	4.00	-	-	-	0.50	2.5	-	-	6.32	60
260	A B	- -	* S/F	60	0.375	0.11	6	4.00	-	-	-	0.50	6.0	-	-	9.48	60
261	A B	- -	S S/F	60	0.375	0.11	6	4.00	-	-	-	0.50	6.0	-	-	9.40	60
262	A B	- -	F/S F/S	60	0.375	0.11	6	4.00	-	-	-	0.50	6.0	-	-	9.40	60
263	A B	0.334 -	F/S SP/S	60	0.375	0.11	6	4.00	-	-	-	0.50	6.0	-	-	9.40	60
264	A B	- 0.952	S/F S/F	60	0.375	0.11	6	4.00	2.4	12	4.0	0.50	4.0	0.375	1	4.74	60

*Test terminated prior to failure of second hooked bar

Table B.3 Cont. Comprehensive test results and data for No. 11 specimens with two hooks

	Specimen	Hook	Bend Angle	Trans. Reinf. Orient.	Hook Bar Type	ℓ_{eh} in.	$\ell_{eh,avg}$ in.	f'_c psi	Age days	d_b in.
265	11-12-90-6#3-i-2.5-2-22	A B	90°	Para	A1035	21.9 21.5	21.7	13710	31	1.41
266	11-15-90-6#3-i-2.5-2-22	A B	90°	Para	A1035	22.3 22.4	22.3	16180	62	1.41
267	11-15-90-6#3-i-2.5-2-9.5	A B	90°	Para	A1035	9.0 10.3	9.6	16180	63	1.41
268	11-15-90-6#3-i-2.5-2-10a [‡]	A B	90°	Para	A615	9.5 10.0	9.8	14045	76	1.41
269	11-15-90-6#3-i-2.5-2-10b [‡]	A B	90°	Para	A615	9.5 9.8	9.6	14050	77	1.41
270	11-15-90-6#3-i-2.5-2-15 [‡]	A B	90°	Para	A1035	14.5 15.0	14.8	14045	80	1.41
271	11-5-90-6#3-i-3.5-2-20	A B	90°	Para	A1035	20.5 20.3	20.4	5420	7	1.41
272	11-8-180-6#3-i-2.5-2-15	A B	180°	Para	A1035	15.1 15.5	15.3	7500	5	1.41
273	11-8-180-6#3-i-2.5-2-19	A B	180°	Para	A1035	19.6 19.9	19.8	7870	6	1.41
274	11-12-180-6#3-i-2.5-2-17	A B	180°	Para	A1035	16.9 16.5	16.7	12370	37	1.41
275	11-12-180-6#3-i-2.5-2-17	A B	180°	Para	A1035	16.8 16.8	16.8	12370	37	1.41
276	11-5-90-5#4s-i-2.5-2-20	A B	90°	Para	A1035	20.0 20.3	20.1	5420	7	1.41
277	11-5-90-5#4s-i-3.5-2-20	A B	90°	Para	A1035	19.8 19.3	19.5	5960	8	1.41

[‡] Specimen contained A1035 Grade 120 for column longitudinal steel

Table B.3 Cont. Comprehensive test results and data for No. 11 specimens with two hooks

	Hook	R_r	b in.	h in.	h_{cl} in.	h_c in.	c_{so} in.	$c_{so,avg}$ in.	c_{th} in.	c_h in.	N_h	Axial Load kips	Long. Reinf. Layout ^o
265	A B	0.085	22.1	24.3	19.5	8.375	2.9 3.1	3.0	2.4 2.8	13.3	2	150	A12
266	A B	0.085	21.8	24.0	19.5	8.375	3.0 2.5	2.8	1.8 1.6	13.5	2	147	A10
267	A B	0.085	21.6	11.5	19.5	8.375	2.5 3.0	2.8	2.5 1.3	13.3	2	69	A2
268	A B	0.085	21.5	12.0	19.5	8.375	2.6 2.8	2.7	2.5 2.0	13.4	2	72	A15
269	A B	0.085	21.4	12.0	19.5	8.375	2.8 2.8	2.8	2.5 2.3	13.0	2	72	A10
270	A B	0.085	21.5	17.0	19.5	8.375	2.6 2.6	2.6	2.5 2.0	13.6	2	102	A15
271	A B	0.085	23.6	22.3	19.5	8.375	3.8 3.9	3.8	1.8 2.0	13.1	2	147	A7
272	A B	0.085	21.8	17.1	19.5	8.375	2.9 3.1	3.0	2.0 1.6	13.0	2	104	A13
273	A B	0.085	21.8	21.2	19.5	8.375	2.9 2.9	2.9	1.5 1.3	13.3	2	129	A13
274	A B	0.085	21.7	19.8	19.5	8.375	2.6 2.8	2.7	2.9 3.3	13.5	2	120	A7
275	A B	0.085	21.4	19.4	19.5	8.375	2.5 2.8	2.6	2.7 2.6	13.4	2	117	A13
276	A B	0.085	21.4	22.3	19.5	8.375	2.5 2.8	2.6	2.3 2.0	13.4	2	134	A7
277	A B	0.085	23.4	22.0	19.5	8.375	3.8 3.8	3.8	2.3 2.8	13.1	2	144	A7

^o Longitudinal column configurations shown in Appendix A, Figures A1 – A16

Table B.3 Cont. Comprehensive test results and data for No. 11 specimens with two hooks

	Hook	T_{max} lb	T_{ind} lb	T_{total} lb	T lb	T_h lb	T/T_h	$f_{su,max}$ psi	f_{su} psi	$f_{s,ACI}$ psi	Joint shear at failure/$\sqrt{f_{cm}}$
265	A B	206283 199234	203983 198395	402379	201189	185650	1.08	132233 127714	128967	160802	4.4
266	A B	204557 195710	200084 195534	395618	197809	199073	0.99	131126 125455	126801	179722	4.1
267	A B	58154 56612	58154 56612	114765	57383	93751	0.61	37278 36290	36784	77527	2.5
268	A B	83558 81804	83558 81804	165362	82681	91774	0.90	53563 52438	53001	73169	3.7
269	A B	76605 74596	76605 74553	151158	75579	90813	0.83	49106 47818	48448	72244	3.4
270	A B	145670 144870	145664 144870	290534	145267	131029	1.11	93378 92866	93120	110692	4.6
271	A B	150216 135259	136607 135036	271643	135821	138606	0.98	96293 86704	87065	94986	4.8
272	A B	112423 110981	112423 110933	223356	111678	116374	0.96	72066 71142	71588	83973	4.8
273	A B	170000 149000	149000 149000	298000	149000	147821	1.01	108974 95513	95513	110947	5.0
274	A B	123150 117638	115105 117638	232743	116371	141920	0.82	78942 75409	74597	117527	3.4
275	A B	148872 173034	148872 148484	297356	148678	142643	1.04	95431 110919	95306	118188	4.4
276	A B	141399 161640	141399 140691	282090	141045	155218	0.91	90640 103615	90414	75057	5.5
277	A B	186703 153546	152402 153532	305934	152967	154532	0.99	119681 98427	98056	76262	5.3

Table B.3 Cont. Comprehensive test results and data for No. 11 specimens with two hooks

	Hook	Slip at Failure in.	Failure Type	f_{yt} ksi	d_{tr} in.	$A_{tr,l}$ in. ²	N_{tr}	s_{tr} in.	A_{cti} in. ²	N_{cti}	s_{cti} in.	d_s in.	s_s in.	d_{cto} in.	N_{cto}	A_s in. ²	f_{ys} ksi
265	A B	- -	S/F F	60	0.375	0.11	6	4.00	3.06	12	4.0	0.50	4.0	0.375	2	6.32	60
266	A B	- -	F/S S/F	60	0.375	0.11	6	4.00	-	-	-	0.50	3.0	-	-	6.32	60
267	A B	0.358 -	F F	60	0.375	0.11	6	4.00	-	-	-	0.50	2.3	-	-	3.16	60
268	A B	- -	F F	60	0.375	0.11	6	4.00	-	-	-	0.50	4.5	-	-	6.94	120
269	A B	- -	F F	60	0.375	0.11	6	4.00	-	-	-	0.50	4.5	-	-	6.32	120
270	A B	- -	F F	60	0.375	0.11	6	4.00	-	-	-	0.50	4.5	-	-	6.94	120
271	A B	- -	S/F S	60	0.375	0.11	6	4.00	1.2	6	4.0	0.50	4.0	0.375	2	4.74	60
272	A B	- -	S S	60	0.375	0.11	6	4.00	-	-	-	0.50	6.0	-	-	9.40	60
273	A B	- -	F/S F/S	60	0.375	0.11	6	4.00	-	-	-	0.50	6.0	-	-	9.40	60
274	A B	- 0.379	F F/S	60	0.375	0.11	6	4.00	-	-	-	0.50	3.0	-	-	4.74	60
275	A B	- -	F/S S/F	60	0.375	0.11	6	4.00	-	-	-	0.50	6.0	-	-	9.40	60
276	A B	- -	F/S F/S	60	0.5	0.20	5	5.00	4	10	5.0	0.50	5.0	0.375	2	4.74	60
277	A B	- -	S/F F/S	60	0.5	0.20	5	5.00	4	10	5.0	0.50	5.0	0.375	2	4.74	60

Table B.4 Comprehensive test results and data for No. 5 specimens with closely-spaced hooks

	Specimen	Hook	Bend Angle	Trans. Reinf. Orient.	Hook Bar Type	ℓ_{eh} in.	$\ell_{eh,avg}$ in.	f'_c psi	Age days	d_b in.
278	(4@4) 5-5-90-0-i-2.5-2-6	A B C D	90°	Para	A1035	5.4 5.3 4.8 5.3	5.2	6430	11	0.625
279	(4@4) 5-5-90-0-i-2.5-2-10	A B C D	90°	Para	A1035	9.0 8.0 9.3 9.9	9.0	6470	12	0.625
280	(4@4) 5-8-90-0-i-2.5-2-6	A B C D	90°	Para	A1035	6.3 5.8 5.8 6.0	5.9	6950	18	0.625
281	(4@6) 5-8-90-0-i-2.5-2-6	A B C D	90°	Para	A1035	6.0 6.0 5.8 6.0	5.9	6693	21	0.625
282	(4@6) 5-8-90-0-i-2.5-6-6	A B C D	90°	Para	A1035	6.3 6.3 6.3 6.3	6.3	6693	21	0.625
283	(3@4) 5-8-90-0-i-2.5-2-6	A B C	90°	Para	A1035	6.0 5.6 6.0	5.9	6950	18	0.625
284	(3@6) 5-8-90-0-i-2.5-2-6	A B C	90°	Para	A1035	6.4 5.9 5.8	6.0	6950	18	0.625
285	(4@4) 5-5-90-2#3-i-2.5-2-6	A B C D	90°	Para	A1035	6.3 6.1 6.3 6.4	6.3	6430	11	0.625
286	(4@4) 5-5-90-2#3-i-2.5-2-8	A B C D	90°	Para	A1035	8.4 7.8 8.0 7.8	8.0	6430	11	0.625
287	(3@6) 5-8-90-5#3-i-2.5-2-6.25	A B C	90°	Para	A1035	5.0 6.3 5.3	5.5	10110	196	0.625
288	(3@4) 5-8-90-5#3-i-2.5-2-6 [‡]	A B C	90°	Para	A1035	6.0 6.3 6.0	6.1	6703	22	0.625
289	(3@6) 5-8-90-5#3-i-2.5-2-6 [‡]	A B C	90°	Para	A1035	6.0 6.0 6.0	6.0	6703	22	0.625
290	(4@4) 5-5-90-5#3-i-2.5-2-7	A B C D	90°	Para	A1035	6.6 7.9 7.5 6.5	7.1	6430	11	0.625
291	(4@4) 5-5-90-5#3-i-2.5-2-6	A B C D	90°	Para	A1035	6.0 6.5 6.6 6.3	6.3	6430	11	0.625

[‡] Specimen contained A1035 Grade 120 for column longitudinal steel

Table B.4 Cont. Comprehensive test results and data for No. 5 specimens with closely-spaced hooks

	Hook	R_r	b in.	h in.	h_{cl} in.	h_c in.	c_{so} in.	$c_{so,avg}$ in.	c_{th} in.	c_h in.	N_h	Axial Load kips	Long. Reinf. Layout
278	A B C D	0.073	13.2	8.2	5.3	8.375	2.4 4.9 5.1 2.8	2.6	2.8 2.9 3.4 2.9	1.9 1.9 1.8	4	30	A1
279	A B C D	0.073	13.2	12.3	5.3	8.375	2.6 5.0 5.0 2.8	2.7	3.3 4.3 3.0 2.4	1.8 1.9 1.6 -	4	30	A1
280	A B C D	0.073	12.9	8.0	5.3	8.375	2.5 5.0 5.0 2.5	2.5	1.8 2.3 2.3 2.0	1.9 1.6 1.9 -	4	30	A2
281	A B C D	0.073	17.3	8.0	5.3	8.375	2.7 6.5 6.5 2.7	2.7	2.0 2.0 2.3 2.0	3.1 3.1 3.1 -	4	30	A2
282	A B C D	0.073	17.1	12.0	5.3	8.375	2.5 6.3 6.5 2.7	2.6	5.8 5.8 5.8 5.8	3.1 3.1 3.1 -	4	30	A7
283	A B C	0.073	10.75	8.0	5.3	8.375	2.6 5.6 2.7	2.6	2.0 2.4 2.0	1.8 1.9 -	3	30	A2
284	A B C	0.073	13.25	8.0	5.3	8.375	2.6 6.2 2.7	2.6	1.6 2.1 2.3	3.0 3.1 -	3	30	A2
285	A B C D	0.073	12.9	8.1	5.3	8.375	2.5 5.0 4.8 2.5	2.5	1.9 2.0 1.9 1.8	1.9 1.9 1.6 -	4	30	A1
286	A B C D	0.073	13.0	10.1	5.3	8.375	2.5 5.0 4.9 2.5	2.5	1.8 2.4 2.1 2.4	1.9 1.9 1.8 -	4	30	A1
287	A B C	0.073	12.75	8.8	5.3	8.375	2.5 5.4 2.5	2.5	3.8 2.6 3.6	2.9 3.0 -	3	30	A1
287	A B C	0.073	10.85	8.0	5.3	8.375	2.5 5.0 2.5	2.5	2.0 1.8 2.0	2.1 1.9 -	3	30	A2
288	A B C	0.073	13.38	8.0	5.3	8.375	2.5 5.0 2.5	2.5	2.0 2.0 2.0	3.4 3.1 -	3	30	A2
290	A B C D	0.073	12.5	9.1	5.3	8.375	2.5 4.6 4.6 2.4	2.4	2.5 1.3 1.6 2.6	1.5 2.0 1.6 -	4	30	A1
291	A B C D	0.073	13.1	8.5	5.3	8.375	2.5 5.1 5.0 2.6	2.6	2.5 2.0 1.9 2.3	2.0 1.8 1.8 -	4	30	A1

° Longitudinal column configurations shown in Appendix A, Figures A1 – A16

Table B.4 Cont. Comprehensive test results and data for No. 5 specimens with closely-spaced hooks

	Hook	T_{max} lb	T_{ind} lb	T_{total} lb	T lb	T_h lb	T/T_h	$f_{su,max}$ psi	f_{su} psi	$f_{s,ACI}$ psi	Joint shear at failure/ $\sqrt{f_{cm}}$
278	A	12150	12150	58167	14542	18697	0.78	39194	46909	47396	4.7
	B	16822	16822					54265			
	C	15517	15510					50055			
	D	13684	13684					44142			
279	A	27937	27938	113608	28402	33820	0.84	90119	91619	83022	6.1
	B	28572	28455					92168			
	C	44806	31762					144535			
	D	27649	25453					89190			
280	A	17307	17307	61916	15479	22136	0.70	55829	49932	56570	5.0
	B	17615	17430					56823			
	C	14066	13684					45374			
	D	14082	13495					45426			
281	A	20647	17356	77211	19303	21896	0.88	66603	62267	55514	4.8
	B	22459	22123					72448			
	C	22914	22649					73916			
	D	15140	15082					48839			
282	A	16185	16185	64205	16051	23119	0.69	52210	51778	58436	2.7
	B	14727	14728					47506			
	C	16472	16472					53135			
	D	16819	16819					54255			
283	A	18497	18326	50416	16805	21890	0.77	59668	54211	55975	4.9
	B	17550	17370					56613			
	C	14720	14720					47484			
284	A	25526	25526	74657	24886	22384	1.11	82342	80277	57166	5.9
	B	34858	25964					112445			
	C	23167	23167					74732			
285	A	22446	21831	85621	21405	26814	0.80	72406	69049	57277	7.1
	B	22211	18818					71648			
	C	24049	23273					77577			
	D	21725	21699					70081			
286	A	23977	23111	104069	26017	33526	0.78	77345	83926	73028	6.9
	B	31206	28774					100665			
	C	35987	28714					116087			
	D	23712	23469					76490			
287	A	27125	27035	77489	25830	35449	0.73	87498	83321	79002	4.8
	B	32375	24934					104436			
	C	27035	25519					87210			
288	A	35751	35751	104667	34889	35170	0.99	115326	112545	71151	10.3
	B	34693	34518					111913			
	C	34397	34397					110958			
289	A	37827	37754	109345	36448	34844	1.05	122023	117576	70176	8.7
	B	34172	34152					110232			
	C	37469	37439					120868			
290	A	27259	26864	108458	27114	38951	0.70	87932	87466	65295	8.3
	B	37030	32039					119452			
	C	29522	29523					95232			
	D	22950	20032					74032			
291	A	24862	24863	103591	25898	35910	0.72	80200	83541	58136	8.1
	B	27208	27018					87768			
	C	26773	26774					86365			
	D	26616	24937					85858			

Table B.4 Cont. Comprehensive test results and data for No. 5 specimens with closely-spaced hooks

	Hook	Slip at Failure in.	Failure Type†	f_{yt} ksi	d_{tr} in.	$A_{tr,l}$ in. ²	N_{tr}	s_{tr} in.	A_{cti} in.	N_{cti}	s_{cti} in.	d_s in.	s_s in.	d_{cto} in.	N_{cto}	A_s in. ²	f_{ys} ksi
278	A B C D	- - - -	F F F F	60	-	-	-	-	1.10	10	2.0	0.375	2.5	0.375	1	1.27	60
279	A B C D	- 0.358 - -	F F F F	60	-	-	-	-	1.10	10	2.0	0.375	3.0	0.500	1	1.27	60
280	A B C D	- - - -	F/S F/S F/S F/S	60	-	-	-	-	-	-	-	0.375	3.0	-	-	3.16	60
281	A B C D	- - - -	F F F F	60	-	-	-	-	-	-	-	0.375	3.0	-	-	3.16	60
282	A B C D	- - - -	F/S F/S F/S F/S	60	-	-	-	-	-	-	-	0.375	3.0	-	-	4.74	60
283	A B C	- - -	F F F	60	-	-	-	-	-	-	-	0.375	3.0	-	-	3.16	60
284	A B C	- - -	F F F	60	-	-	-	-	-	-	-	0.375	3.0	-	-	3.16	60
285	A B C D	- 0.23 - 0.484	F F F F	60	0.38	0.11	2	4.0	0.66	6	4.0	0.375	3.0	0.375	2	1.27	60
286	A B C D	- 0.365 - 0.398	F F F F	60	0.38	0.11	2	5.0	1.20	6	2.5	0.375	3.0	0.500	2	1.27	60
287	A B C	- - -	F F F	60	0.38	0.11	5	2	-	-	-	0.50	3.0	0.375	1	1.27	60
288	A B C	- - -	F F F	60	0.38	0.11	5	2	-	-	-	0.38	3.0	-	-	3.16	120
289	A B C	- - -	F F F	60	0.38	0.11	5	2	-	-	-	0.38	3.0	-	-	3.16	120
290	A B C D	- - - -	F F F F	60	0.38	0.11	5	1.8	0.55	5	1.8	0.375	2.8	0.500	2	1.27	60
291	A B C D	- - 0.333 -	F F F F	60	0.38	0.11	5	2.0	0.55	5	2.0	0.375	3.0	0.375	2	1.27	60

Table B.4 Cont. Comprehensive test results and data for No. 5 specimens with closely-spaced hooks

	Specimen	Hook	Bend Angle	Trans. Reinf. Orient.	Hook Bar Type	ℓ_{eh} in.	$\ell_{eh,avg}$ in.	f'_c psi	Age days	d_b in.
292	(4@6) 5-8-90-5#3-i-2.5-2-6 [‡]	A B C D	90°	Para	A1035	6.0 6.0 6.0 6.0	6.0	6693	21	0.625
293	(4@6) 5-8-90-5#3-i-2.5-6-6 [‡]	A B C D	90°	Para	A1035	6.8 6.0 6.5 6.3	6.4	6693	21	0.625
294	(4@4) 5-8-90-5#3-i-2.5-2-6 [‡]	A B C D	90°	Para	A1035	5.8 5.5 6.3 6.5	6.0	6703	22	0.625
295	(3@6) 5-8-90-5#3-i-3.5-2-6.25	A B C	90°	Para	A1035	6.3 6.3 6.3	6.3	10110	196	0.625

[‡] Specimen contained A1035 Grade 120 for column longitudinal steel

Table B.4 Cont. Comprehensive test results and data for No. 5 specimens with closely-spaced hooks

	Hook	R_r	b in.	h in.	h_{cl} in.	h_c in.	c_{so} in.	$c_{so,avg}$ in.	c_{th} in.	c_h in.	N_h	Axial Load kips	Long. Reinf. Layout
292	A B C D	0.073	17.8	8.0	5.3	8.375	2.7 6.5 6.5 2.7	2.7	2.0 2.0 2.0 2.0	3.4 3.4 3.1 -	4	30	A2
293	A B C D	0.073	16.8	8.0	5.3	8.375	2.5 6.5 6.5 2.7	2.6	1.3 2.0 1.5 1.8	3.1 3.1 2.9 -	4	30	A7
294	A B C D	0.073	13.1	8.0	5.3	8.375	2.5 5.0 5.0 2.5	2.5	2.3 2.5 1.8 1.5	1.9 1.9 1.9 -	4	30	A2
295	A B C	0.073	15	8.3	5.3	8.375	3.5 6.6 3.8	3.6	2.1 2.1 2.1	2.6 3.3 -	3	30	A1

[°] Longitudinal column configurations shown in Appendix A, Figures A1 – A16

Table B.4 Cont. Comprehensive test results and data for No. 5 specimens with closely-spaced hooks

	Hook	T_{max} lb	T_{ind} lb	T_{total} lb	T lb	T_h lb	T/T_h	$f_{su,max}$ psi	f_{su} psi	$f_{s,ACI}$ psi	Joint shear at failure/ $\sqrt{f_{cm}}$
292	A	30306	30282	113284	28321	34834	0.81	97761	91358	56099	6.8
	B	30095	30085								
	C	27572	27573								
	D	25343	25344								
293	A	3210	32083	124607	31152	36304	0.86	10354	100489	59605	7.9
	B	29935	29930								
	C	30839	30839								
	D	31800	31755								
294	A	27967	27968	109970	27493	34844	0.79	90216	88686	56141	8.9
	B	27348	27348								
	C	28550	28551								
	D	26208	26103								
295	A	36112	36112	105803	35268	38751	0.91	116491	113766	89775	5.9
	B	33789	33344								
	C	40826	36347								

Table B.4 Cont. Comprehensive test results and data for No. 5 specimens with closely-spaced hooks

	Hook	Slip at Failure in.	Failure Type†	f_{yt} ksi	d_{tr} in.		N_{tr}	S_{tr} in.	A_{cti} in.	N_{cti}	S_{cti} in.	d_s in.	s_s in.	d_{cto} in.	N_{cto}	A_s in. ²	f_{ys} ksi
292	A	-	F	60	0.38	0.11	5	1.7	-	-	-	0.375	3.0	-	-	3.16	120
	B	-	F														
	C	-	F														
	D	-	F														
293	A	-	F	60	0.38	0.11	5	1.7	-	-	-	0.375	3.0	-	-	4.74	120
	B	-	F														
	C	-	F														
	D	-	F														
294	A	-	F	60	0.38	0.11	5	1.7	-	-	-	0.375	3.0	-	-	3.16	120
	B	-	F														
	C	-	F														
	D	-	F														
295	A	-	F	60	0.38	0.11	5	2	-	-	-	0.50	3.0	0.375	1	1.27	60
	B	-	F														
	C	0.454	F														

Table B.5 Comprehensive test results and data for No. 8 specimens with closely-spaced hooks

	Specimen	Hook	Bend Angle	Trans. Reinf. Orient.	Hook Bar Type	l_{eh} in.	$l_{eh,avg}$ in.	f'_c psi	Age days	d_b in.
296	(3@5.5) 8-5-90-0-i-2.5-2-16	A B C	90°	Para	A1035 ^b	16.5 15.8 16.0	16.1	6255	13	1
297	(3@5.5) 8-5-90-0-i-2.5-2-10	A B C	90°	Para	A1035 ^b	9.0 9.4 9.8	9.4	6461	14	1
298	(3@5.5) 8-5-90-0-i-2.5-2-8 [‡]	A B C	90°	Para	A615	7.5 8.0 8.0	7.8	5730	18	1
299	(3@3) 8-5-90-0-i-2.5-2-10 [‡]	A B C	90°	Para	A615	10.0 10.3 10.0	10.1	4490	10	1
300	(3@5) 8-5-90-0-i-2.5-2-10 [‡]	A B C	90°	Para	A615	10.3 10.1 10.0	10.1	4490	10	1
301	(3@5.5) 8-8-90-0-i-2.5-2-8	A B C	90°	Para	A1035 ^b	7.8 8.8 7.3	7.9	8700	24	1
302	(3@3) 8-8-90-0-i-2.5-9-9	A B C	90°	Para	A615	9.5 9.5 9.3	9.4	7510	21	1
303	(3@4) 8-8-90-0-i-2.5-9-9	A B C	90°	Para	A615	9.3 9.3 9.3	9.3	7510	21	1
304	(3@3) 8-12-90-0-i-2.5-2-12 [‡]	A B C	90°	Para	A1035 ^c	12.1 12.1 12.2	12.1	11040	31	1
305	(3@4) 8-12-90-0-i-2.5-2-12 [‡]	A B C	90°	Para	A1035 ^c	12.9 12.5 12.5	12.6	11440	32	1
306	(3@5) 8-12-90-0-i-2.5-2-12 [‡]	A B C	90°	Para	A1035 ^c	12.3 12.0 12.3	12.2	11460	33	1
307	(4@3) 8-8-90-0-i-2.5-9-9	A B C D	90°	Para	A615	9.4 9.3 9.3 9.6	9.4	7510	21	1
308	(4@4) 8-8-90-0-i-2.5-9-9	A B C D	90°	Para	A615	9.4 9.1 9.0 9.1	9.2	7510	21	1
309	(3@3) 8-5-180-0-i-2.5-2-10 [‡]	A B C	180°	Para	A615	9.8 10.0 9.8	9.8	5260	15	1
310	(3@5) 8-5-180-0-i-2.5-2-10 [‡]	A B C	180°	Para	A615	10.0 10.0 10.0	10.0	5260	15	1
311	(3@5.5) 8-5-90-2#3-i-2.5-2-14	A B C	90°	Para	A1035 ^b	14.6 13.9 14.8	14.4	6460	14	1
312	(3@5.5) 8-5-90-2#3-i-2.5-2-8.5	A B C	90°	Para	A1035 ^b	9.8 8.8 8.9	9.1	6460	14	1

[‡] Specimen contained A1035 Grade 120 for column longitudinal steel

^a Heat 1, ^b Heat 2, ^c Heat 3 as described in Table 2.3

Table B.5 Cont. Comprehensive test results and data for No. 8 specimens with closely-spaced hooks

	Hook	R_r	b in.	h in.	h_{cl} in.	h_c in.	c_{so} in.	$c_{so,avg}$ in.	c_{th} in.	c_h in.	N_h	Axial Load kips	Long. Reinf. Layout
296	A	0.078	17.3	18.1	10.5	8.375	2.6	2.7	1.6	4.4	3	30	A2
	B						8.0		2.4	4.5			
	C						2.8		2.1	-			
297	A	0.078	16.9	12.2	10.5	8.375	2.6	2.6	3.2	4.4	3	30	A2
	B						7.9		2.8	4.4			
	C						2.5		2.4	-			
298	A	0.073	17	10.0	10.5	8.375	2.5	2.5	2.5	4.5	3	30	A10
	B						8.0		2.0	4.5			
	C						2.5		2.0	-			
299	A	0.073	12.8	12.0	10.5	8.375	2.6	2.6	2.0	2.4	3	30	A2
	B						5.5		1.8	2.3			
	C						2.5		2.0	-			
300	A	0.073	16	12.0	10.5	8.375	2.3	2.4	1.8	4.0	3	30	A2
	B						7.3		1.9	4.3			
	C						2.5		2.0	-			
301	A	0.078	16.4	10.1	10.5	8.375	3.0	2.9	2.4	4.3	3	30	A2
	B						8.2		1.4	3.4			
	C						2.8		2.9	-			
302	A	0.073	12.3	18.0	10.5	8.375	2.5	2.5	8.5	2.1	3	30	A7
	B						5.6		8.5	2.1			
	C						2.5		8.8	-			
303	A	0.073	14.1	18.0	10.5	8.375	2.5	2.5	8.8	3.0	3	30	A7
	B						6.5		8.8	3.1			
	C						2.5		8.8	-			
304	A	0.073	12.1	14.0	10.5	8.375	2.5	2.5	1.8	2.1	3	30	A2
	B						5.4		1.9	2.0			
	C						2.4		1.8	-			
305	A	0.073	13.9	14.1	10.5	8.375	2.5	2.5	1.3	2.9	3	30	A2
	B						6.4		1.6	3.0			
	C						2.5		1.6	-			
306	A	0.073	15.9	14.0	10.5	8.375	2.4	2.4	1.8	4.0	3	30	A2
	B						7.4		2.0	4.0			
	C						2.5		1.8	-			
307	A	0.073	15.0	18.0	10.5	8.375	2.5	2.5	8.6	2.0	4	30	A12
	B						5.5		8.8	2.0			
	C						5.5		8.8	2.0			
	D						2.5		8.4	-			
308	A	0.073	18.3	18.0	10.5	8.375	2.5	2.5	8.6	3.1	4	30	A12
	B						6.6		8.9	3.1			
	C						6.5		9.0	3.0			
	D						2.5		8.9	-			
309	A	0.073	11.6	12.0	10.5	8.375	2.4	2.3	2.3	2.0	3	30	A10
	B						5.4		2.0	2.0			
	C						2.3		2.3	-			
310	A	0.073	16.5	12.0	10.5	8.375	2.5	2.5	2.0	4.3	3	30	A10
	B						7.8		2.0	4.3			
	C						2.5		2.0	-			
311	A	0.078	17.1	16.1	10.5	8.375	2.8	2.6	1.5	4.4	3	30	A2
	B						8.0		2.2	4.5			
	C						2.5		1.3	-			
312	A	0.078	16.5	10.7	10.5	8.375	2.5	2.5	0.9	4.3	3	30	A4
	B						7.8		1.9	4.3			
	C						2.5		1.8	-			

^o Longitudinal column configurations shown in Appendix A, Figures A1 – A16

Table B.5 Cont. Comprehensive test results and data for No. 8 specimens with closely-spaced hooks

	Hook	T_{max} lb	T_{ind} lb	T_{total} lb	T lb	T_h lb	T/T_h	$f_{su,max}$ psi	f_{su} psi	$f_{s,ACI}$ psi	Joint shear at failure/ $\sqrt{f_{cm}}$
296	A	65266	65265	188393	62798	79580	0.79	82615	79491	90858	4.6
	B	103741	76608					131318			
	C	46521	46520					58887			
297	A	26783	26683	108161	36054	45333	0.80	33903	45637	53826	4.0
	B	57434	55164					72701			
	C	26314	26314					33309			
298	A	30459	30459	73234	24411	36190	0.67	38556	30900	42354	3.4
	B	23292	23292					29484			
	C	19482	19482					24661			
299	A	30671	30671	85439	28480	44067	0.65	38824	36050	48261	5.0
	B	43708	33363					55327			
	C	21404	21405					27094			
300	A	30145	30145	96899	32300	44159	0.73	38158	40886	48357	4.6
	B	38965	34709					49323			
	C	3259	32045					4126			
301	A	41000	37670	113010	37670	41310	0.91	51899	47684	52744	4.4
	B	41000	37670					51899			
	C	41000	37670					51899			
302	A	24580	24580	64314	21438	47578	0.45	31114	27137	58289	2.0
	B	25019	25019					31670			
	C	14714	14714					18625			
303	A	29402	29403	79058	26353	46686	0.56	37218	33358	57258	2.2
	B	27244	27226					34486			
	C	22429	22429					28391			
304	A	56490	56461	144116	48039	69551	0.69	71506	60808	90999	4.9
	B	46273	38034					58573			
	C	55048	49621					69681			
305	A	56769	56681	167466	55822	73348	0.76	71859	70661	96453	4.8
	B	76126	57568					96362			
	C	57723	53216					73067			
306	A	53307	53307	157056	52352	70564	0.74	67477	66268	93033	4.0
	B	66123	42900					83700			
	C	60849	60849					77024			
307	A	22186	22181	74637	18659	47355	0.39	28083	23619	58031	1.9
	B	21191	21153					26824			
	C	18263	18251					23117			
	D	13052	13052					16521			
308	A	20362	20362	72146	18036	46184	0.39	25775	22831	56677	1.5
	B	19012	19012					24066			
	C	18477	18449					23389			
	D	14323	14323					18130			
309	A	37063	37064	141746	47249	44925	1.05	46915	59809	50941	8.5
	B	59803	59799					75700			
	C	44883	44884					56814			
310	A	41465	40204	137789	45930	45732	1.00	52487	58139	51804	5.8
	B	60400	59739					76456			
	C	37920	37846					48000			
311	A	66835	66811	171782	57261	76760	0.75	84601	72482	82766	4.7
	B	65764	42778					83246			
	C	62311	62193					78875			
312	A	25157	24718	122656	40885	49278	0.83	31844	51754	52387	5.2
	B	68732	58920					87003			
	C	39164	39019					49575			

Table B.5 Cont. Comprehensive test results and data for No. 8 specimens with closely-spaced hooks

	Hook	Slip at Failure in.	Failure Type	f_{yt} ksi	d_{tr} in.	$A_{tr,t}$ in. ²	N_{tr}	S_{tr} in.	A_{cti} in.	N_{cti}	S_{cti} in.	d_s in.	s_s in.	d_{cto} in.	N_{cto}	A_s in. ²	f_{ys} ksi
296	A B C	- 0.191 -	F F F	60	-	-	-	-	2.0	10	3	0.50	3.0	0.375	1	3.16	60
297	A B C	- - -	F F F	60	-	-	-	-	2.0	10	3	0.50	3.0	0.500	1	3.16	60
298	A B C	- - 0.15	F F F	60	-	-	-	-	-	-	-	0.50	4.0	-	-	6.32	120
299	A B C	0.09 0.12 0	F F F	60	-	-	-	-	-	-	-	0.38	3.0	-	-	3.16	120
300	A B C	0.015 - -	F F F	60	-	-	-	-	-	-	-	0.38	4.0	-	-	3.16	120
301	A B C	- - -	F F F	60	-	-	0	-	2.2	20	3	0.50	1.8	-	-	3.16	60
302	A B C	- - -	F F F	60	-	-	-	-	-	-	-	0.38	4.0	-	-	4.74	60
303	A B C	- - 0.026	F F F	60	-	-	-	-	-	-	-	0.38	4.0	-	-	4.74	60
304	A B C	0.194 - -	S F F	60	0.38	0.11	0	-	-	-	-	0.38	3.0	-	-	3.16	120
305	A B C	0.255 - -	F/S F F/S	60	0.38	0.11	0	-	-	-	-	0.38	3.0	-	-	3.16	120
306	A B C	- - -	F F F	60	0.38	0.11	0	-	-	-	-	0.38	3.0	-	-	3.16	120
307	A B C D	- - - -	F F F F	60	0.38	0.11	0	3.0	-	-	-	0.375	4.0	-	-	6.32	60
308	A B C D	- - - -	F F F F	60	0.38	0.11	0	0.0	-	-	-	0.375	4.0	-	-	6.32	60
309	A B C	- - -	F F F	60	-	0.11	-	-	-	-	-	0.50	4.0	-	-	6.32	120
310	A B C	- - 0.123	F F F	60	-	0.11	-	-	-	-	-	0.50	3.0	-	-	6.32	120
311	A B C	- - -	F F F	60	0.38	0.11	2	8	2.0	10	2.5	0.38	3.0	0.500	2	3.16	60
312	A B C	0.215 0.285 -	F F F	60	0.38	0.11	2	8	2.0	10	2.5	0.38	2.5	0.500	2	1.89	60

Table B.5 Cont. Comprehensive test results and data for No. 8 specimens with closely-spaced hooks

	Specimen	Hook	Bend Angle	Trans. Reinf. Orient.	Hook Bar Type	l_{eh} in.	$l_{eh,avg}$ in.	f'_c psi	Age days	d_b in.
313	(3@5.5) 8-5-90-2#3-i-2.5-2-14(1)	A B C	90°	Para	A1035 ^c	14.7 15.2 14.8	14.9	5450	7	1
314	(3@5.5) 8-5-90-2#3-i-2.5-2-8.5(1)	A B C	90°	Para	A1035 ^c	7.3 8.9 8.4	8.2	5450	7	1
315	(3@3) 8-5-90-2#3-i-2.5-2-10 [‡]	A B C	90°	Para	A615	9.9 10.1 10.0	10.0	4760	11	1
316	(3@5) 8-5-90-2#3-i-2.5-2-10 [‡]	A B C	90°	Para	A615	10.5 10.6 10.4	10.5	4760	11	1
317	(3@3) 8-5-180-2#3-i-2.5-2-10 [‡]	A B C	180°	Para	A615	10.5 10.3 10.0	9.4	5400	16	1
318	(3@5) 8-5-180-2#3-i-2.5-2-10 [‡]	A B C	180°	Para	A615	9.6 9.8 9.8	9.4	5400	16	1
319	(3@5.5) 8-5-90-5#3-i-2.5-2-8	A B C	90°	Para	A1035 ^b	8.0 8.1 7.8	8.0	6620	15	1
320	(3@5.5) 8-5-90-5#3-i-2.5-2-12	A B C	90°	Para	A1035 ^b	12.4 12.1 12.1	12.2	6620	15	1
321	(3@5.5) 8-5-90-5#3-i-2.5-2-8(1)	A B C	90°	Para	A1035 ^c	7.3 8.4 7.3	7.6	5660	8	1
322	(3@5.5) 8-5-90-5#3-i-2.5-2-12(1)	A B C	90°	Para	A1035 ^c	11.4 12.5 12.0	12.0	5660	8	1
323	(3@5.5) 8-5-90-5#3-i-2.5-2-8(2) [‡]	A B C	90°	Para	A615	8.0 8.0 8.5	8.2	5730	18	1
324	(3@3) 8-5-90-5#3-i-2.5-2-10 [‡]	A B C	90°	Para	A615	10.0 9.8 9.9	9.9	4810	12	1
325	(3@5) 8-5-90-5#3-i-2.5-2-10 [‡]	A B C	90°	Para	A615	10.0 10.0 9.8	9.9	4850	13	1
326	(3@3) 8-8-90-5#3-i-2.5-9-9	A B C	90°	Para	A615	9.5 9.0 9.5	9.3	7440	22	1
327	(3@4) 8-8-90-5#3-i-2.5-9-9	A B C	90°	Para	A615	8.9 9.1 9.3	9.1	7440	22	1
328	(3@3) 8-12-90-5#3-i-2.5-2-12 [‡]	A B C	90°	Para	A1035 ^c	11.9 11.9 11.6	11.8	11040	31	1
329	(3@4) 8-12-90-5#3-i-2.5-2-12 [‡]	A B C	90°	Para	A1035 ^c	12.5 12.0 12.5	12.3	11440	32	1

[‡] Specimen contained A1035 Grade 120 for column longitudinal steel

^a Heat 1, ^b Heat 2, ^c Heat 3 as described in Table 2.3

Table B.5 Cont. Comprehensive test results and data for No. 8 specimens with closely-spaced hooks

	Hook	R_r	b in.	h in.	h_{cl} in.	h_c in.	c_{so} in.	$c_{so,avg}$ in.	c_{th} in.	c_h in.	N_h	Axial Load kips	Long. Reinf. Layout
313	A B C	0.073	16.8	16.4	10.5	8.375	2.8 7.9 2.6	2.7	1.7 1.2 1.6	4.2 4.3 -	3	30	A2
314	A B C	0.073	16.8	10.8	10.5	8.375	2.3 7.9 2.6	2.5	3.5 1.8 2.3	4.5 4.3 -	3	30	A2
315	A B C	0.073	12.1	12.0	10.5	8.375	2.6 5.6 2.5	2.6	2.1 1.9 2.0	2.0 2.0 -	3	30	A7
316	A B C	0.073	16.6	12.0	10.5	8.375	2.5 8.0 2.8	2.6	1.5 1.4 1.6	4.5 3.9 -	3	30	A2
317	A B C	0.073	12.3	11.1	10.5	8.375	2.5 5.5 2.8	2.6	1.5 1.8 2.0	2.0 2.0 -	3	30	A10
318	A B C	0.073	16.1	11.7	10.5	8.375	2.5 7.8 2.3	2.4	2.4 2.3 2.3	4.2 4.2 -	3	30	A10
319	A B C	0.078	16.6	10.2	10.5	8.375	2.5 7.6 2.5	2.5	2.2 2.1 2.4	4.1 4.5 -	3	30	A10
320	A B C	0.078	16.8	14.2	10.5	8.375	2.5 7.8 2.5	2.5	1.8 2.1 2.1	4.3 4.5 -	3	30	A1
321	A B C	0.073	16.6	10.1	10.5	8.375	2.9 7.6 2.9	2.9	2.9 1.8 2.9	3.8 4.1 -	3	30	A2
322	A B C	0.073	16.9	14.2	10.5	8.375	2.5 7.8 2.6	2.6	2.8 1.7 2.2	4.3 4.5 -	3	30	A2
323	A B C	0.073	17	10.0	10.5	8.375	2.8 8.0 2.3	2.5	2.0 2.0 1.5	4.5 4.5 -	3	30	A10
324	A B C	0.073	12.3	12.0	10.5	8.375	2.8 5.9 2.3	2.5	2.0 2.3 2.1	2.1 2.1 -	3	30	A7
325	A B C	0.073	16.3	12.0	10.5	8.375	2.5 7.5 2.8	2.6	2.0 2.0 2.3	4.0 4.0 -	3	30	A3
326	A B C	0.073	12	18.0	10.5	8.375	2.5 5.5 2.5	2.5	8.5 9.0 8.5	2.0 2.0 -	3	30	A7
327	A B C	0.073	14	18.0	10.5	8.375	2.5 6.5 2.5	2.5	9.1 8.9 8.8	3.0 3.0 -	3	30	A7
328	A B C	0.073	12	14.1	10.5	8.375	2.5 5.5 2.5	2.5	2.3 2.3 2.5	2.0 2.0 -	3	30	A2
329	A B C	0.073	13.8	14.3	10.5	8.375	2.5 6.3 2.5	2.5	1.8 2.3 1.8	2.8 3.0 -	3	30	A2

° Longitudinal column configurations shown in Appendix A, Figures A1 – A16

Table B.5 Cont. Comprehensive test results and data for No. 8 specimens with closely-spaced hooks

	Hook	T_{max} lb	T_{ind} lb	T_{total} lb	T lb	T_h lb	T/T_h	$f_{su,max}$ psi	f_{su} psi	$f_{s,ACI}$ psi	Joint shear at failure/ $\sqrt{f_{cm}}$
313	A	58682	58531	196009	65336	75615	0.86	74281	82704	78438	5.8
	B	97141	67310					122963			
	C	70217	70168					88882			
314	A	36593	35595	97104	32368	42708	0.76	46320	40972	43284	4.4
	B	43607	30047					55199			
	C	35210	31462					44570			
315	A	42191	42191	122162	40721	49552	0.82	53406	51545	49174	7.4
	B	4159	41586					5264			
	C	38385	38385					48589			
316	A	43315	43030	134004	44668	52012	0.86	54829	56542	51745	5.9
	B	54636	48236					69159			
	C	42769	42739					54138			
317	A	59807	59807	163728	54576	48262	1.13	75705	69083	49208	9.9
	B	56145	56145					71070			
	C	47776	47776					60476			
318	A	59312	59313	154502	51501	48262	1.07	75078	65191	49208	6.8
	B	4934	49344					6246			
	C	45845	45845					58032			
319	A	30586	30530	111379	37126	55126	0.67	38716	46995	57814	4.9
	B	46989	46919					59480			
	C	34069	33930					43125			
320	A	60325	60281	198283	66094	77151	0.86	76361	83664	88689	6.2
	B	110823	80058					140282			
	C	59279	57944					75037			
321	A	29839	29789	94108	31369	51796	0.61	37771	39708	51219	4.5
	B	30241	29643					38280			
	C	34714	34676					43942			
322	A	55543	44226	143554	47851	73216	0.65	70308	60571	80327	4.8
	B	74581	74581					94406			
	C	44410	24747					56215			
323	A	57652	57652	143982	47994	54575	0.88	72977	60752	55196	6.8
	B	43308	43309					54820			
	C	43030	43021					54468			
324	A	48766	48766	141829	47276	60722	0.78	61729	59843	61149	8.4
	B	44849	44503					56771			
	C	48560	48560					61468			
325	A	58896	58896	183916	61305	61025	1.00	74552	77602	61662	8.2
	B	63376	55612					80223			
	C	69408	69408					87858			
326	A	43346	43346	119286	39762	63754	0.62	54868	50332	71880	3.9
	B	49666	38730					62868			
	C	37210	37211					47101			
327	A	48534	48534	109678	36559	62532	0.58	61435	46278	70115	3.1
	B	38602	30171					48863			
	C	31956	30973					40451			
328	A	70368	68183	186619	62206	84276	0.74	89073	78742	110622	6.3
	B	84954	56310					107537			
	C	62126	62127					78641			
329	A	70706	69965	194819	64940	88303	0.74	89501	82202	117781	5.6
	B	100028	68745					126618			
	C	63666	56110					80590			

Table B.5 Cont. Comprehensive test results and data for No. 8 specimens with closely-spaced hooks

	Hook	Slip at Failure in.	Failure Type	f_{yt} ksi	d_{tr} in.	$A_{tr,l}$ in. ²	N_{tr}	s_{tr} in.	A_{cti} in.	N_{cti}	s_{cti} in.	d_s in.	s_s in.	d_{cto} in.	N_{cto}	A_s in. ²	f_{ys} ksi
313	A B C	- - -	F/TK F/TK F/TK	60	0.38	0.11	2	6	1.6	8	3	0.38	2.5	0.375	2	3.16	60
314	A B C	- - -	F F F	60	0.38	0.11	2	6	2.0	10	3	0.50	2.5	0.375	1	3.16	60
315	A B C	0.26 0.18 -	F F F	60	0.38	0.11	2	3	-	-	-	0.50	5.0	-	-	4.74	120
316	A B C	0.26 0.26 -	F F F	60	0.38	0.11	2	3	-	-	-	0.38	3.0	-	-	3.16	120
317	A B C	- - 0.32	F F F	60	0.38	0.11	2	3	-	-	-	0.50	4.0	-	-	6.32	120
318	A B C	- - 0.14	F F F	60	0.38	0.11	2	3	-	-	-	0.50	3.0	-	-	6.32	120
319	A B C	0.388 0.477 -	F F F	60	0.38	0.11	5	3	2.0	10	3.3	0.38	2.5	0.500	2	1.89	60
320	A B C	0.198 - -	F F F	60	0.38	0.11	5	3	2.0	10	3.2	0.38	2.5	0.500	2	1.27	60
321	A B C	- 0.297 0.381	F F F	60	0.38	0.11	5	3	2.0	10	3	0.50	2.5	0.375	1	3.16	60
322	A B C	- 0.435 0.927	F F F	60	0.38	0.11	5	3	1.0	5	2.8	0.50	3.5	0.500	1	3.16	60
323	A B C	- - 0.54	F F F	60	0.38	0.11	5	3	-	-	-	0.50	4.0	-	-	6.32	120
324	A B C	- 0.13 0	F F F	60	0.38	0.11	5	3	-	-	-	0.50	4.0	-	-	4.74	120
325	A B C	- - -	F F F	60	0.38	0.11	5	3	-	-	-	0.38	3.0	-	-	3.95	120
326	A B C	- - -	F F F	60	0.38	0.11	5	3	-	-	-	0.38	4.0	-	-	4.74	60
327	A B C	0.1 - -	F F F	60	0.38	0.11	5	3	-	-	-	0.38	4.0	-	-	4.74	60
328	A B C	0.302 0.256 0.251	F F F	60	0.38	0.11	5	3	-	-	-	0.38	3.0	-	-	3.16	120
329	A B C	0.262 - 0.205	F F F	60	0.38	0.11	5	3	-	-	-	0.38	3.0	-	-	3.16	120

Table B.5 Cont. Comprehensive test results and data for No. 8 specimens with closely-spaced hooks

	Specimen	Hook	Bend Angle	Trans. Reinf. Orient.	Hook Bar Type	l_{eh} in.	$l_{eh,avg}$ in.	f'_c psi	Age days	d_b in.
330	(3@5) 8-12-90-5#3-i-2.5-2-12 [‡]	A B C	90°	Para	A1035 [°]	11.9 12.4 12.3	12.2	11460	33	1
331	(4@3)8-8-90-5#3-i-2.5-9-9	A B C D	90°	Para	A615	9.3 9.3 9.3 9.3	9.3	7440	22	1
332	(4@4) 8-8-90-5#3-i-2.5-9-9	A B C D	90°	Para	A615	9.5 9.5 9.3 9.6	9.5	7440	22	1
333	(3@3) 8-5-180-5#3-i-2.5-2-10 [‡]	A B C	180°	Para	A615	10.1 9.9 9.8	9.9	5540	17	1
334	(3@5) 8-5-180-5#3-i-2.5-2-10 [‡]	A B C	180°	Para	A615	9.9 9.8 9.5	9.7	5540	17	1

[‡] Specimen contained A1035 Grade 120 for column longitudinal steel

[°] Heat 1, ^b Heat 2, ^c Heat 3 as described in Table 2.3

Table B.5 Cont. Comprehensive test results and data for No. 8 specimens with closely-spaced hooks

	Hook	R_r	b in.	h in.	h_{cl} in.	h_c in.	c_{so} in.	$c_{so,avg}$ in.	c_{th} in.	c_h in.	N_h	Axial Load kips	Long. Reinf. Layout
330	A B C	0.073	16	14.1	10.5	8.375	2.5 7.5 2.5	2.5	2.2 1.7 1.8	4.0 4.0 -	3	30	A2
331	A B C D	0.073	15.3	18.0	10.5	8.375	2.5 5.5 5.5 2.5	2.5	8.8 8.8 8.8 8.8	2.0 2.3 2.0 -	4	30	A7
332	A B C D	0.073	18.0	18.0	10.5	8.375	2.5 6.5 6.5 2.5	2.5	8.5 8.5 8.8 8.4	3.0 3.0 3.0 -	4	30	A7
333	A B C	0.073	12.5	12.0	10.5	8.375	2.8 5.8 2.8	2.8	1.9 2.1 2.3	2.0 2.0 -	3	30	A10
334	A B C	0.073	15.8	12.0	10.5	8.375	2.3 7.0 2.8	2.5	2.1 2.3 2.5	3.8 4.0 -	3	30	A10

[°] Longitudinal column configurations shown in Appendix A, Figures A1 – A16

Table B.5 Cont. Comprehensive test results and data for No. 8 specimens with closely-spaced hooks

	Hook	T_{max} lb	T_{ind} lb	T_{total} lb	T lb	T_h lb	T/T_h	$f_{su,max}$ psi	f_{su} psi	$f_{s,ACI}$ psi	Joint shear at failure/ $\sqrt{f_{cm}}$
330	A	59447	59447	194282	64761	87571	0.74	75249	81976	116689	4.9
	B	85455	65587					108171			
	C	69248	69248					87656			
331	A	32930	32930	125763	31441	46559	0.68	41683	39798	56990	2.6
	B	38749	38749					49049			
	C	27318	27290					34580			
	D	26809	26794					33936			
332	A	33657	33657	117937	29484	47727	0.62	42604	37322	58338	9.6
	B	30733	30723					38902			
	C	27886	27886					35299			
	D	25671	25671					32495			
333	A	50346	46175	176632	58877	62766	0.94	63729	74528	65903	9.6
	B	67397	65274					85313			
	C	66969	65183					84771			
334	A	55363	55236	176006	58669	61742	0.95	70080	74264	64518	7.6
	B	60892	60892					77078			
	C	59877	59877					75794			

Table B.5 Cont. Comprehensive test results and data for No. 8 specimens with closely-spaced hooks

	Hook	Slip at Failure in.	Failure Type	f_y ksi	d_{tr} in.	$A_{tr,l}$ in. ²	N_{tr}	s_{tr} in.	A_{cti} in.	N_{cti}	s_{cti} in.	d_s in.	s_s in.	d_{cto} in.	N_{cto}	A_s in. ²	f_{ys} ksi
330	A	-	F	60	0.38	0.11	5	3	-	-	-	0.38	3.0	-	-	3.16	120
	B	-	F														
	C	0.18	F														
331	A		F	60	0.38	0.11	5	3.0	-	-	-	0.375	4.0	-	-	4.74	60
	B		F														
	C		F														
	D		F														
332	A		F	60	0.38	0.11	5	3.0	-	-	-	0.375	4.0	-	-	4.74	60
	B		F														
	C		F														
	D		F														
333	A		F	60	0.38	0.11	5	3	-	-	-	0.50	4.0	-	-	6.32	120
	B		F														
	C	0.269	F														
334	A		F	60	0.38		5	3	-	-	-	0.50	3.0	-	-	6.32	120
	B		F														
	C	0.382	F														

Table B.6 Comprehensive test results and data for No. 11 specimens with closely-spaced hooks

	Specimen	Hook	Bend Angle	Trans. Reinf. Orient.	Hook Bar Type	l_{eh} in.	$l_{eh,avg}$ in.	f'_c psi	Age days	d_b in.
335	(3@5.35) 11-5-90-0-i-2.5-13-13	A B C	90°	Para	A615	13.8 14.3 13.5	13.8	5330	11	1.41
336	(3@5.35) 11-5-90-2#3-i-2.5-13-13	A B C	90°	Para	A615	14.0 14.0 13.8	13.9	5330	11	1.41
337	(3@5.35) 11-5-90-6#3-i-2.5-13-13	A B C	90°	Para	A615	13.5 13.5 13.8	13.6	5280	12	1.41
338	(3@5.35) 11-5-90-6#3-i-2.5-18-18	A B C	90°	Para	A1035	18.6 18.6 18.6	18.6	5280	12	1.41

Table B.6 Cont. Comprehensive test results and data for No. 11 specimens with closely-spaced hooks

	Hook	R_r	b in.	h in.	h_{cl} in.	h_c in.	c_{so} in.	$c_{so,avg}$ in.	c_{th} in.	c_h in.	N_h	Axial Load kips	Long. Reinf. Layout ^o
335	A B C	0.085	22.3	26.0	19.5	8.375	2.6 10.0 2.6	2.6	12.3 11.8 12.5	6.6 6.3 -	3	162	A14
336	A B C	0.085	21.5	26.0	19.5	8.375	2.6 10.0 2.6	2.6	12.0 12.0 12.3	6.1 6.1 -	3	157	A14
337	A B C	0.085	21.3	26.0	19.5	8.375	2.6 10.0 2.7	2.6	12.5 12.5 12.3	6.0 5.8 -	3	155	A14
338	A B C	0.085	21.2	36.0	19.5	8.375	2.5 10.0 2.8	2.7	17.4 17.4 17.4	6.1 5.6 -	3	214	A14

^o Longitudinal column configurations shown in Appendix A, Figures A1 – A16

Table B.6 Cont. Comprehensive test results and data for No. 11 specimens with closely-spaced hooks

	Hook	T_{max} lb	T_{ind} lb	T_{total} lb	T lb	T_h lb	T/Th	$f_{su,max}$ psi	f_{su} psi	$f_{s,ACI}$ psi	Joint shear at failure/ $\sqrt{f_{cm}}$
335	A B C	45416 49897 59323	45405 49897 59215	154517	51506	154517	51506	29113 31985 38028	33016	51162	2.5
336	A B C	50926 58487 64473	50926 58487 64349	173762	57921	173762	57921	32645 37492 41329	37129	51470	2.9
337	A B C	59664 66536 72350	59647 66536 72350	198533	66178	198533	66178	38246 42651 46378	42422	50001	3.4
338	A B C	103312 147805 113923	100804 121063 113733	335601	111867	335601	111867	66226 94747 73027	71710	68559	4.2

Table B.6 Cont. Comprehensive test results and data for No. 11 specimens with closely-spaced hooks

	Hook	Slip at Failure in.	Failure Type	f_{yt} ksi	d_{tr} in.	$A_{tr,l}$ in. ²	N_{tr}	S_{tr} in.	A_{cti} in.	N_{cti}	S_{cti} in.	d_s in.	s_s in.	d_{cto} in.	N_{cto}	A_s in. ²	f_{ys} ksi
335	A	0.113	F	60	-	-	-	-	-	-	-	0.50	7.0	-	-	7.90	60
	B	-	F														
	C	-	F														
336	A	-	F	60	0.38	0.11	2	8	-	-	-	0.50	7.0	-	-	7.90	60
	B	-	F														
	C	-	F														
337	A	-	F	60	0.38	0.11	6	4	-	-	-	0.50	7.0	-	-	7.90	60
	B	-	F														
	C	-	F														
338	A	-	F	60	0.38	0.11	6	4	-	-	-	0.50	7.0	-	-	7.90	60
	B	-	F														
	C	-	F														

APPENDIX C: TEST-TO-CALCULATED RATIOS FOR SPECIMENS USED IN CHAPTER 4

Table C.1 Test-to-calculated ratios for specimens with two widely-spaced hooked bars without confining reinforcement

Specimen		T	Descriptive Equation ^a		Design Equation ^b	
			T _h	T/T _h	T _h	T/T _h
		lb	lb		lb	
1	5-5-90-0-i-2.5-2-10	33583	33080	1.02	27480	1.22
2	5-5-90-0-i-2.5-2-7	26265	23988	1.09	20297	1.29
3	5-8-90-0-i-2.5-2-6	29570	26839	1.10	22307	1.33
4	5-8-90-0-i-2.5-2-6(1)	22425	25525	0.88	21240	1.06
5	5-8-90-0-i-2.5-2-8	31673	31209	1.01	25710	1.23
6	5-12-90-0-i-2.5-2-10	41657	45391	0.92	36452	1.14
7	5-12-90-0-i-2.5-2-5	19220	21121	0.91	17662	1.09
8	5-15-90-0-i-2.5-2-5.5	32511	28089	1.16	22945	1.42
9	5-15-90-0-i-2.5-2-7.5	42221	34712	1.22	28017	1.51
10	5-5-90-0-i-3.5-2-10	41927	36985	1.13	30536	1.37
11	5-5-90-0-i-3.5-2-7	26516	26284	1.01	22125	1.20
12	5-8-90-0-i-3.5-2-6	25475	25110	1.01	20941	1.22
13	5-8-90-0-i-3.5-2-6(1)	24541	26783	0.92	22213	1.10
14	5-8-90-0-i-3.5-2-8	32745	34452	0.95	28238	1.16
15	5-12-90-0-i-3.5-2-5	22121	22672	0.98	18932	1.17
16	5-12-90-0-i-3.5-2-10	45432	44924	1.01	35995	1.26
17	5-8-180-0-i-2.5-2-7	27108	29561	0.92	24394	1.11
18	5-8-180-0-i-3.5-2-7	30754	29831	1.03	24604	1.25
19	8-5-90-0-i-2.5-2-16	83239	75922	1.10	59976	1.39
20	8-5-90-0-i-2.5-2-9.5	44485	43624	1.02	35533	1.25
21	8-5-90-0-i-2.5-2-12.5	65819	61559	1.07	49151	1.34
22	8-5-90-0-i-2.5-2-18	80881	89312	0.91	69780	1.16
23	8-5-90-0-i-2.5-2-13	65539	63253	1.04	50356	1.30
24	8-5-90-0-i-2.5-2-15(1)	63767	72061	0.88	56864	1.12
25	8-5-90-0-i-2.5-2-15	75478	72778	1.04	57331	1.32
26	(2@3) 8-5-90-0-i-2.5-2-10 [‡]	40313	45999	0.88	37475	1.08
27	(2@5) 8-5-90-0-i-2.5-2-10 [‡]	40052	43959	0.91	35904	1.12
28	8-8-90-0-i-2.5-2-8	45243	42993	1.05	34693	1.30
29	8-8-90-0-i-2.5-2-10	51455	49048	1.05	39311	1.31
30	8-8-90-0-i-2.5-2-8(1)	36821	41882	0.88	33764	1.09
31	8-8-90-0-i-2.5sc-2tc-9 [‡]	35100	48392	0.73	38813	0.90
32	8-12-90-0-i-2.5-2-9	49923	50870	0.98	40332	1.24
33	8-12-90-0-i-2.5-2-12.5	66937	75268	0.89	58284	1.15
34	8-12-90-0-i-2.5-2-12	65879	70837	0.93	55052	1.20
35	8-15-90-0-i-2.5-2-8.5	43575	55024	0.79	43077	1.01

^a Eq. (3.2)

^b Eq. (4.13)

[‡] Specimen contained A1035 Grade 120 for column longitudinal steel

Table C.1 Cont. Test-to-calculated ratios for specimens with two widely-spaced hooked bars without confining reinforcement

Specimen		T	Descriptive Equation ^a		Design Equation ^b	
			T_h	T/T_h	T_h	T/T_h
		lb	lb		lb	
36	8-15-90-0-i-2.5-2-13	78120	81605	0.96	62478	1.25
37	8-5-90-0-i-3.5-2-18	95372	88362	1.08	69080	1.38
38	8-5-90-0-i-3.5-2-13	68099	63253	1.08	50356	1.35
39	8-5-90-0-i-3.5-2-15(2)	87709	71213	1.23	56408	1.55
40	8-5-90-0-i-3.5-2-15(1)	70651	75854	0.93	59563	1.19
41	8-8-90-0-i-3.5-2-8(1)	43845	39289	1.12	31866	1.38
42	8-8-90-0-i-3.5-2-10	55567	49724	1.12	39821	1.40
43	8-8-90-0-i-3.5-2-8(2)	42034	43271	0.97	34819	1.21
44	8-12-90-0-i-3.5-2-9	60238	50870	1.18	40332	1.49
45	8-8-90-0-i-4-2-8	37431	40788	0.92	32935	1.14
46	8-5-180-0-i-2.5-2-11	46143	48511	0.95	39390	1.17
47	8-5-180-0-i-2.5-2-14	49152	63773	0.77	50913	0.97
48	8-8-180-0-i-2.5-2-11.5	71484	48606	1.47	38871	1.84
49	8-12-180-0-i-2.5-2-12.5	75208	74101	1.01	57431	1.31
50	8-5-180-0-i-3.5-2-11	59292	51437	1.15	41628	1.42
51	8-5-180-0-i-3.5-2-14	63504	64377	0.99	51367	1.24
52	11-5-90-0-i-2.5-2-14	66590	79286	1.01	62298	1.07
53	11-5-90-0-i-2.5-2-26	148727	152421	1.17	115176	1.29
54	11-8-90-0-i-2.5-2-17	132055	119020	1.34	89991	1.47
55	11-8-90-0-i-2.5-2-21	125126	132865	1.13	100269	1.25
56	11-8-90-0-i-2.5-2-17	104779	112427	1.12	85491	1.23
57	11-12-90-0-i-2.5-2-17	134371	118562	1.36	89183	1.51
58	11-12-90-0-i-2.5-2-17.5	124622	131960	1.14	98394	1.27
59	11-12-90-0-i-2.5-2-25	199743	187403	1.28	136987	1.46
60	11-15-90-0-i-2.5-2-24	213265	196102	1.31	142326	1.50
61	11-15-90-0-i-2.5-2-10 [‡]	51481	69331	0.89	53547	0.96
62	11-15-90-0-i-2.5-2-15 [‡]	92168	104578	1.06	78912	1.17
63	11-5-90-0-i-3.5-2-17	108122	103770	1.25	80055	1.35
64	11-5-90-0-i-3.5-2-14	69514	82944	1.01	65007	1.07
65	11-5-90-0-i-3.5-2-26	182254	157184	1.40	118272	1.54
66	11-8-180-0-i-2.5-2-21	128123	136292	1.13	102707	1.25
67	11-8-180-0-i-2.5-2-17	100453	117199	1.03	88910	1.13
68	11-12-180-0-i-2.5-2-17	107461	119514	1.08	89859	1.20

^a Eq. (3.2)

^b Eq. (4.13)

[‡] Specimen contained A1035 Grade 120 for column longitudinal steel

Table C.2 Test-to-calculated ratios for specimens with two widely-spaced hooked bars with confining reinforcement

Specimen		<i>T</i>	Descriptive Equation ^a		Design Equation ^b	
			<i>T_h</i>	<i>T/T_h</i>	<i>T_h</i>	<i>T/T_h</i>
		lb	lb		lb	
1	5-5-90-1#3-i-2.5-2-8	33136	31349	1.06	26327	1.26
2	5-5-90-1#3-i-2.5-2-6	19915	21933	0.91	18755	1.06
3	5-8-90-1#3-i-2.5-2-6	26573	28174	0.94	23581	1.13
4	5-8-90-1#3-i-2.5-2-6(1)	27379	27780	0.99	23225	1.18
5	5-8-90-1#3-i-3.5-2-6	30084	27859	1.08	23318	1.29
6	5-8-90-1#3-i-3.5-2-6(1)	25905	29307	0.88	24432	1.06
7	5-5-180-1#3-i-2.5-2-8	36448	32111	1.14	26894	1.36
8	5-5-180-1#3-i-2.5-2-6	23916	25201	0.95	21387	1.12
9	5-8-180-1#3-i-2.5-2-7	32909	33456	0.98	27668	1.19
10	5-8-180-1#3-i-3.5-2-7	30500	32272	0.95	26752	1.14
11	5-5-90-1#4-i-2.5-2-8	27537	33925	0.81	28323	0.97
12	5-5-90-1#4-i-2.5-2-6	21457	26892	0.80	22658	0.95
13	5-8-90-1#4-i-2.5-2-6	24292	31688	0.77	26275	0.92
14	5-8-90-1#4-i-3.5-2-6	25241	33887	0.74	28008	0.90
15	5-5-180-1#4-i-2.5-2-8	38421	35550	1.08	29610	1.30
16	5-5-180-1#4-i-2.5-2-6	22977	29499	0.78	24765	0.93
17	5-5-90-2#3-i-2.5-2-8	37154	31904	1.16	26711	1.39
18	5-5-90-2#3-i-2.5-2-6	29444	24732	1.19	21011	1.40
19	5-8-90-2#3-i-2.5-2-6	30638	27755	1.10	23244	1.32
20	5-8-90-2#3-i-2.5-2-8	40168	37614	1.07	30959	1.30
21	5-12-90-2#3-i-2.5-2-5	24348	28463	0.86	23678	1.03
22	5-15-90-2#3-i-2.5-2-6	42638	34250	1.24	27975	1.52
23	5-15-90-2#3-i-2.5-2-4	18667	21220	0.88	17831	1.05
24	5-5-90-2#3-i-3.5-2-6	21093	24118	0.87	20560	1.03
25	5-5-90-2#3-i-3.5-2-8	44665	30822	1.45	25921	1.72
26	5-8-90-2#3-i-3.5-2-6	30035	28807	1.04	24073	1.25
27	5-8-90-2#3-i-3.5-2-8	28656	32368	0.89	26857	1.07
28	5-12-90-2#3-i-3.5-2-5	28364	26634	1.06	22271	1.27
29	5-5-180-2#3-i-2.5-2-8	34078	36883	0.92	30607	1.11
30	5-5-180-2#3-i-2.5-2-6	26728	28154	0.95	23642	1.13
31	5-8-180-2#3-i-2.5-2-7	29230	37280	0.78	30652	0.95
32	5-8-180-2#3-i-3.5-2-7	30931	35933	0.86	29600	1.04
33	5-8-90-4#3-i-2.5-2-8	26411	38991	0.68	32031	0.82
34	5-8-90-4#3-i-3.5-2-8	38480	42178	0.91	34504	1.12
35	5-5-90-5#3-i-2.5-2-7	31696	34446	0.92	28521	1.11

^a Eq. (3.2)

^b Eq. (4.13)

Table C.2 Cont. Test-to-calculated ratios for specimens with two widely-spaced hooked bars with confining reinforcement

Specimen		<i>T</i> lb	Descriptive Equation ^a		Design Equation ^b	
			<i>T_h</i> lb	<i>T/T_h</i>	<i>T_h</i> lb	<i>T/T_h</i>
36	5-12-90-5#3-i-2.5-2-5	34420	35366	0.97	28949	1.19
37	5-15-90-5#3-i-2.5-2-4	31318	31021	1.01	25354	1.24
38	5-15-90-5#3-i-2.5-2-5	39156	36416	1.08	29581	1.32
39	5-5-90-5#3-i-3.5-2-7	36025	37369	0.96	30862	1.17
40	5-12-90-5#3-i-3.5-2-5	30441	33822	0.90	27703	1.10
41	8-5-90-1#3-i-2.5-2-16	74809	76769	0.97	60976	1.23
42	8-5-90-1#3-i-2.5-2-12.5	64837	62777	1.03	50370	1.29
43	8-5-90-1#3-i-2.5-2-9.5	62233	46082	1.35	37609	1.65
44	8-5-180-1#3-i-2.5-2-11	49732	55252	0.90	44826	1.11
45	8-5-180-1#3-i-2.5-2-14	69021	73355	0.94	58402	1.18
46	8-5-180-1#3-i-3.5-2-11	55390	54323	1.02	44061	1.26
47	8-5-180-1#3-i-3.5-2-14	75994	74142	1.02	59000	1.29
48	8-8-180-1#4-i-2.5-2-11.5	72231	74846	0.97	58794	1.23
49	8-5-90-2#3-i-2.5-2-16	79629	75532	1.05	60050	1.33
50	8-5-90-2#3-i-2.5-2-9.5	53621	46453	1.15	37910	1.41
51	8-5-90-2#3-i-2.5-2-12.5	72067	60649	1.19	48738	1.48
52	8-5-90-2#3-i-2.5-2-8.5	50561	47286	1.07	38537	1.31
53	8-5-90-2#3-i-2.5-2-14	76964	69985	1.10	55733	1.38
54	(2@3) 8-5-90-2#3-i-2.5-2-10 [‡]	46810	50832	0.92	41344	1.13
55	(2@5) 8-5-90-2#3-i-2.5-2-10 [‡]	48515	48772	0.99	39760	1.22
56	8-8-90-2#3-i-2.5-2-8	47876	46882	1.02	37918	1.26
57	8-8-90-2#3-i-2.5-2-10	61024	56882	1.07	45352	1.35
58	8-12-90-2#3-i-2.5-2-9	61013	56097	1.09	44555	1.37
59	8-12-90-2#3-i-2.5-2-11	68683	68734	1.00	53860	1.28
60	8-12-90-2#3vr-i-2.5-2-11	52673	64971	0.81	50907	1.03
61	8-15-90-2#3-i-2.5-2-11	83320	74830	1.11	57994	1.44
62	8-5-90-2#3-i-3.5-2-17	89914	88104	1.02	69198	1.30
63	8-5-90-2#3-i-3.5-2-13	80360	69734	1.15	55521	1.45
64	8-8-90-2#3-i-3.5-2-8	48773	46759	1.04	37766	1.29
65	8-8-90-2#3-i-3.5-2-10	53885	51599	1.04	41372	1.30
66	8-12-90-2#3-i-3.5-2-9	49777	56097	0.89	44555	1.12
67	8-5-180-2#3-i-2.5-2-11	60235	57658	1.04	46494	1.30
68	8-5-180-2#3-i-2.5-2-14	76279	73578	1.04	58528	1.30
69	8-8-180-2#3-i-2.5-2-11.5	58171	66123	0.88	52272	1.11
70	8-12-180-2#3-i-2.5-2-11	64655	67961	0.95	53290	1.21

^a Eq. (3.2)

^b Eq. (4.13)

[‡] Specimen contained A1035 Grade 120 for column longitudinal steel

Table C.2 Cont. Test-to-calculated ratios for specimens with two widely-spaced hooked bars with confining reinforcement

Specimen		T lb	Descriptive Equation ^a		Design Equation ^b	
			T _h lb	T/T _h	T _h lb	T/T _h
71	8-12-180-2#3vr-i-2.5-2-11	65780	66517	0.99	52048	1.26
72	8-5-180-2#3-i-3.5-2-11	55869	55752	1.00	45078	1.24
73	8-5-180-2#3-i-3.5-2-14	63467	72672	0.87	57845	1.10
74	8-15-180-2#3-i-2.5-2-11	78922	75135	1.05	58237	1.36
75	8-8-90-2#4-i-2.5-2-10	61360	55832	1.10	44602	1.38
76	8-8-90-2#4-i-3.5-2-10	69463	58583	1.19	46682	1.49
77	8-5-90-4#3-i-2.5-2-16	90429	84844	1.07	66997	1.35
78	8-5-90-4#3-i-2.5-2-12.5	68583	64929	1.06	51959	1.32
79	8-5-90-4#3-i-2.5-2-9.5	54914	53922	1.02	43519	1.26
80	8-5-90-5#3-i-2.5-2-10b	69715	64769	1.08	51520	1.35
81	8-5-90-5#3-i-2.5-2-10c	68837	65920	1.04	52362	1.31
82	8-5-90-5#3-i-2.5-2-15	73377	87983	0.83	69181	1.06
83	8-5-90-5#3-i-2.5-2-13	82376	81257	1.01	63968	1.29
84	8-5-90-5#3-i-2.5-2-12(1)	66363	68375	0.97	54332	1.22
85	8-5-90-5#3-i-2.5-2-12	72000	73010	0.99	57684	1.25
86	8-5-90-5#3-i-2.5-2-12(2)	71470	73090	0.98	57881	1.23
87	8-5-90-5#3-i-2.5-2-8	47478	50723	0.94	40724	1.17
88	8-5-90-5#3-i-2.5-2-10a	82800	64937	1.28	51677	1.60
89	(2@3) 8-5-90-5#3-i-2.5-2-10 [‡]	57922	62480	0.93	49879	1.16
90	(2@5) 8-5-90-5#3-i-2.5-2-10 [‡]	55960	59824	0.94	47837	1.17
91	8-8-90-5#3-i-2.5-2-8	50266	53859	0.93	42833	1.17
92	8-8-90-5#3-i-2.5-2-9 [*]	64397	61438	1.05	48675	1.32
93	8-12-90-5#3-i-2.5-2-9	64753	67620	0.96	53003	1.22
94	8-12-90-5#3-i-2.5-2-10	64530	71117	0.91	55557	1.16
95	8-12-90-5#3-i-2.5-2-12 [‡]	87711	88168	0.99	68148	1.29
96	8-12-90-5#3vr-i-2.5-2-10	60219	67059	0.90	52438	1.15
97	8-12-90-4#3vr-i-2.5-2-10	59241	66818	0.89	52287	1.13
98	8-15-90-5#3-i-2.5-2-10	90003	80498	1.12	62164	1.45
99	8-5-90-5#3-i-3.5-2-15	80341	89047	0.90	69977	1.15
100	8-5-90-5#3-i-3.5-2-13	77069	78783	0.98	62108	1.24
101	8-5-90-5#3-i-3.5-2-12(1)	76431	74137	1.03	58705	1.30
102	8-5-90-5#3-i-3.5-2-12	79150	76237	1.04	60029	1.32
103	8-8-90-5#3-i-3.5-2-8	55810	57384	0.97	45565	1.22
104	8-12-90-5#3-i-3.5-2-9 [*]	67831	67620	1.00	53003	1.28
105	8-12-180-5#3-i-2.5-2-10	64107	73027	0.88	56977	1.13

^a Eq. (3.2)

^b Eq. (4.13)

[‡] Specimen contained A1035 Grade 120 for column longitudinal steel

Table C.2 Cont. Test-to-calculated ratios for specimens with two widely-spaced hooked bars with confining reinforcement

Specimen		T	Descriptive Equation ^a		Design Equation ^b	
			T _h	T/T _h	T _h	T/T _h
		lb	lb		lb	
106	8-12-180-5#3vr-i-2.5-2-10	67780	70708	0.96	55136	1.23
107	8-12-180-4#3vr-i-2.5-2-10	69188	65665	1.05	51434	1.35
108	8-15-180-5#3-i-2.5-2-9.5	85951	77095	1.11	59685	1.44
109	8-5-90-4#4s-i-2.5-2-15	93653	92056	1.02	72093	1.30
110	8-5-90-4#4s-i-2.5-2-12(1)	90816	77607	1.17	61132	1.49
111	8-5-90-4#4s-i-2.5-2-12	99755	80367	1.24	63013	1.58
112	8-5-90-4#4s-i-3.5-2-15	90865	90541	1.00	70958	1.28
113	8-5-90-4#4s-i-3.5-2-12(1)	95455	77612	1.23	60994	1.56
114	8-5-90-4#4s-i-3.5-2-12	98156	79340	1.24	62287	1.58
115	11-5-90-1#4-i-2.5-2-17	101498	115679	1.03	88998	1.14
116	11-5-90-1#4-i-3.5-2-17	106270	116068	1.08	89280	1.19
117	11-5-90-2#3-i-2.5-2-17	100695	108250	1.11	83671	1.20
118	11-5-90-2#3-i-2.5-2-14	77422	81310	1.13	64063	1.21
119	11-12-90-2#3-i-2.5-2-17.5	130389	139941	1.11	104454	1.25
120	11-15-90-2#3-i-2.5-2-23	209575	195050	1.28	142233	1.47
121	11-15-90-2#3-i-2.5-2-10 [‡]	63940	79600	0.95	61376	1.04
122	11-15-90-2#3-i-2.5-2-15 [‡]	115189	111959	1.22	84625	1.36
123	11-5-90-2#3-i-3.5-2-17	109644	115784	1.13	88687	1.24
124	11-5-90-2#3-i-3.5-2-14	82275	83132	1.17	65417	1.26
125	11-5-90-5#3-i-2.5-2-14	95170	96880	1.13	75177	1.27
126	11-5-90-5#3-i-3.5-2-14	97989	100897	1.12	78157	1.25
127	11-5-90-6#3-i-2.5-2-20	136272	131706	1.21	100558	1.36
128	11-8-90-6#3-i-2.5-2-16	132986	126362	1.23	95679	1.39
129	11-8-90-6#3-i-2.5-2-22	184569	166360	1.30	124068	1.49
130	11-8-90-6#3-i-2.5-2-22	191042	170431	1.32	126937	1.51
131	11-8-90-6#3-i-2.5-2-15	108312	117618	1.07	89724	1.21
132	11-8-90-6#3-i-2.5-2-19	145430	142479	1.19	107641	1.35
133	11-12-90-6#3-i-2.5-2-17	161648	142884	1.32	106841	1.51
134	11-12-90-6#3-i-2.5-2-16	115197	135193	1.00	101179	1.14
135	11-12-90-6#3-i-2.5-2-22	201189	185650	1.28	136543	1.47
136	11-15-90-6#3-i-2.5-2-22	197809	199073	1.17	145329	1.36
137	11-15-90-6#3-i-2.5-2-10a [‡]	82681	91774	1.04	69998	1.18
138	11-15-90-6#3-i-2.5-2-10b [‡]	75579	90813	0.96	69298	1.09
139	11-15-90-6#3-i-2.5-2-15 [‡]	145267	131029	1.29	98178	1.48

^a Eq. (3.2)

^b Eq. (4.13)

[‡] Specimen contained A1035 Grade 120 for column longitudinal steel

Table C.2 Cont. Test-to-calculated ratios for specimens with two widely-spaced hooked bars with confining reinforcement

Specimen		T	Descriptive Equation ^a		Design Equation ^b	
			T_h	T/Th	Th	T/Th
		lb	lb		lb	
140	11-5-90-6#3-i-3.5-2-20	135821	138606	1.15	105555	1.29
141	11-8-180-6#3-i-2.5-2-15	111678	116374	1.12	88821	1.26
142	11-8-180-6#3-i-2.5-2-19	149000	147821	1.18	111353	1.34
143	11-12-180-6#3-i-2.5-2-17	116371	141920	0.96	106159	1.10
144	11-12-180-6#3-i-2.5-2-17	148678	142643	1.22	106671	1.39
145	11-5-90-5#4s-i-2.5-2-20	141045	155218	1.04	116755	1.21
146	11-5-90-5#4s-i-3.5-2-20	152967	154532	1.13	116060	1.32

^a Eq. (3.2)

^b Eq. (4.13)

Table C.3 Test-to-calculated ratios for specimens with closely-spaced hooked bars without confining reinforcement

Specimen		T	Descriptive Equation ^a		Design Equation ^b	
			T_h	T/Th	Th	T/Th
		lb	lb		lb	
1	(4@4) 5-5-90-0-i-2.5-2-6	14542	14002	1.04	11996	1.21
2	(4@4) 5-5-90-0-i-2.5-2-10	28402	24929	1.14	20651	1.38
3	(4@4) 5-8-90-0-i-2.5-2-6	15479	16824	0.92	13785	1.12
4	(4@6) 5-8-90-0-i-2.5-2-6	19303	19966	0.97	17291	1.12
5	(3@4) 5-8-90-0-i-2.5-2-6	16805	16264	1.03	14250	1.18
6	(3@6) 5-8-90-0-i-2.5-2-6	24886	20436	1.22	16930	1.47
7	(3@5.5) 8-5-90-0-i-2.5-2-16	62798	69342	0.91	54505	1.15
8	(3@5.5) 8-5-90-0-i-2.5-2-10	36054	40002	0.90	32435	1.11
9	(3@3) 8-5-90-0-i-2.5-2-10 [‡]	28480	29501	0.97	24183	1.18
10	(3@5) 8-5-90-0-i-2.5-2-10 [‡]	32300	37622	0.86	30824	1.05
11	(3@5.5) 8-8-90-0-i-2.5-2-8	37670	35328	1.07	28597	1.32
12	(3@3) 8-12-90-0-i-2.5-2-12 [‡]	48039	47124	1.02	36852	1.30
13	(3@4) 8-12-90-0-i-2.5-2-12 [‡]	55822	55744	1.00	43412	1.29
14	(3@5) 8-12-90-0-i-2.5-2-12 [‡]	52352	59987	0.87	46803	1.12
15	(3@5) 8-5-180-0-i-2.5-2-10 [‡]	45930	39616	1.16	32263	1.42

^a Eq. (3.2)

^b Eq. (4.13)

[‡] Specimen contained A1035 Grade 120 for column longitudinal steel

Table C.4 Test-to-calculated ratios for specimens with closely-spaced hooked bars with confining reinforcement

Specimen		T lb	Descriptive Equation ^a		Design Equation ^b	
			T_h lb	T/Th	T_h lb	T/Th
1	(4@4) 5-5-90-2#3-i-2.5-2-6	21405	19435	1.10	17137	1.25
2	(4@4) 5-5-90-2#3-i-2.5-2-8	26017	24709	1.05	21478	1.21
3	(3@6) 5-8-90-5#3-i-2.5-2-6.25	25830	29355	0.88	27049	0.95
4	(3@4) 5-8-90-5#3-i-2.5-2-6 [‡]	34889	27047	1.29	24100	1.45
5	(3@6) 5-8-90-5#3-i-2.5-2-6 [‡]	36448	28889	1.26	24364	1.50
6	(4@4) 5-5-90-5#3-i-2.5-2-7	27114	28478	0.95	25383	1.07
7	(4@4) 5-5-90-5#3-i-2.5-2-6	25898	25641	1.01	23060	1.12
8	(4@6) 5-8-90-5#3-i-2.5-2-6 [‡]	28321	26606	1.06	22706	1.25
9	(4@4) 5-8-90-5#3-i-2.5-2-6 [‡]	27493	24850	1.11	22288	1.23
10	(3@6) 5-8-90-5#3-i-3.5-2-6.25	35268	32230	1.09	24623	1.43
11	(3@5.5) 8-5-90-2#3-i-2.5-2-14	57261	66980	0.85	53493	1.07
12	(3@5.5) 8-5-90-2#3-i-2.5-2-8.5	40885	42850	0.95	35102	1.16
13	(3@5.5) 8-5-90-2#3-i-2.5-2-14(1)	65336	65659	1.00	52718	1.24
14	(3@5.5) 8-5-90-2#3-i-2.5-2-8.5(1)	32368	36987	0.88	30666	1.06
15	(3@3) 8-5-90-2#3-i-2.5-2-10 [‡]	40721	34718	1.17	29519	1.38
16	(3@5) 8-5-90-2#3-i-2.5-2-10 [‡]	44668	42135	1.06	34909	1.28
17	(3@5.5) 8-5-90-5#3-i-2.5-2-8	37126	45956	0.81	37947	0.98
18	(3@5.5) 8-5-90-5#3-i-2.5-2-12	66094	66495	0.99	53904	1.23
19	(3@5.5) 8-5-90-5#3-i-2.5-2-8(1)	31369	42254	0.74	35465	0.88
20	(3@5.5) 8-5-90-5#3-i-2.5-2-12(1)	47851	62684	0.76	51208	0.93
21	(3@3) 8-5-90-5#3-i-2.5-2-10 [‡]	47276	46114	1.03	41119	1.15
22	(3@5) 8-5-90-5#3-i-2.5-2-10 [‡]	61305	50243	1.22	42230	1.45
23	(3@3) 8-12-90-5#3-i-2.5-2-12 [‡]	62206	66260	0.94	56836	1.09
24	(3@4) 8-12-90-5#3-i-2.5-2-12 [‡]	64940	72539	0.90	60178	1.08
25	(3@5) 8-12-90-5#3-i-2.5-2-12 [‡]	64761	74782	0.87	60328	1.07

^a Eq. (3.2)

^b Eq. (4.13)

[‡] Specimen contained A1035 Grade 120 for column longitudinal steel

Table C.5 Test-to-calculated ratios for specimens with hooked bars outside column core

Specimen		T	Descriptive Equation ^a		Design Equation ^b	
			T _h	T/T _h	T _h	T/T _h
		lb	lb		lb	
1	5-5-90-0-o-1.5-2-5	14069	16701	0.84	11553	1.22
2	5-5-90-0-o-1.5-2-6.5	17813	21824	0.82	14822	1.20
3	5-5-90-0-o-1.5-2-8	23455	28121	0.83	18827	1.25
4	5-5-90-0-o-2.5-2-5	19283	15817	1.22	10975	1.76
5	5-5-90-0-o-2.5-2-8	30340	32611	0.93	21639	1.40
6	5-5-180-0-o-1.5-2-9.5	29486	31727	0.93	21219	1.39
7	5-5-180-0-o-1.5-2-11.25	32374	38470	0.84	25436	1.27
8	5-5-180-0-o-2.5-2-9.5	30128	32158	0.94	21480	1.40
9	8-5-90-0-o-2.5-2-10a	42314	47578	0.89	30833	1.37
10	8-5-90-0-o-2.5-2-10b	33651	44958	0.75	29207	1.15
11	8-5-90-0-o-2.5-2-10c	55975	49790	1.12	32131	1.74
12	8-8-90-0-o-2.5-2-8	33015	44255	0.75	28456	1.16
13	8-8-90-0-o-3.5-2-8	35872	40883	0.88	26400	1.36
14	8-8-90-0-o-4-2-8	37511	42709	0.88	27525	1.36
15	11-8-90-0-o-2.5-2-25	174765	173772	1.21	102883	1.70
16	11-8-90-0-o-2.5-2-17	107209	111429	1.16	67653	1.58
17	11-12-90-0-o-2.5-2-17	105402	121183	1.05	72845	1.45
18	11-12-180-0-o-2.5-2-17	83493	122610	0.82	73654	1.13
19	5-5-180-2#3-o-1.5-2-11.25	43051	43309	0.99	28668	1.50
20	5-5-180-2#3-o-1.5-2-9.5	20282	36939	0.61	19784	1.03
21	5-5-180-2#3-o-2.5-2-9.5	39698	34799	1.14	23328	1.70
22	5-5-180-2#3-o-2.5-2-11.25	42324	42432	1.00	28108	1.51
23	5-5-90-5#3-o-1.5-2-5	22060	25225	0.74	17054	1.29
24	5-5-90-5#3-o-1.5-2-8	25110	40815	0.62	26841	0.94
25	5-5-90-5#3-o-1.5-2-6.5	21711	35791	0.61	23642	0.92
26	5-5-90-5#3-o-2.5-2-5	22529	29921	0.75	19912	1.13
27	5-5-90-5#3-o-2.5-2-8	28429	39398	0.72	25944	1.10
28	8-5-90-5#3-o-2.5-2-10a	54257	64329	0.84	40970	1.32
29	8-5-90-5#3-o-2.5-2-10b	65592	65382	1.00	41590	1.58
30	8-5-90-5#3-o-2.5-2-10c	57700	67783	0.85	43023	1.34
31	8-8-90-5#3-o-2.5-2-8	57981	61189	0.95	38713	1.50
32	8-8-90-5#3-o-3.5-2-8	54957	57980	0.95	36748	1.50
33	8-8-90-5#3-o-4-2-8	39071	59964	0.65	37960	1.03
34	11-8-90-6#3-o-2.5-2-16	136753	129138	1.23	78088	1.75
35	11-8-90-6#3-o-2.5-2-22	170249	168582	1.19	100575	1.69
36	11-12-90-6#3-o-2.5-2-17	115878	138370	0.98	82993	1.40
37	11-12-180-6#3-o-2.5-2-17	113121	138845	0.95	83263	1.36

^a Eq. (3.2)

^b Eq. (4.13)

Table C.6 Test-to-calculated ratios for specimens with hooked bars extended halfway through the column depth

Specimen		T	Descriptive Equation ^a		Design Equation ^b	
			T_h	T/Th	T_h	T/Th
		lb	lb		lb	
1	(2@3) 8-8-90-0-i-2.5-9-9	30672	46017	0.67	20068	1.53
2	(2@4) 8-8-90-0-i-2.5-9-9	34195	50372	0.68	24941	1.37
3	(2@5.35) 11-5-90-0-i-2.5-13-13	60593	78578	0.77	43316	1.40
4	(4@6) 5-8-90-0-i-2.5-6-6	16051	23119	0.69	14398	1.11
5	(3@3) 8-8-90-0-i-2.5-9-9	21438	47578	0.45	21019	1.02
6	(3@4) 8-8-90-0-i-2.5-9-9	26353	46686	0.56	23056	1.14
7	(4@3) 8-8-90-0-i-2.5-9-9	18659	47355	0.39	22902	0.81
8	(4@4) 8-8-90-0-i-2.5-9-9	18036	46184	0.39	20617	0.87
9	(3@5.35) 11-5-90-0-i-2.5-13-13	51506	77956	0.66	42811	1.20
10	(2@3) 8-8-90-5#3-i-2.5-9-9	58792	63977	0.92	37709	1.56
11	(2@4) 8-8-90-5#3-i-2.5-9-9	57455	61977	0.93	37069	1.55
12	(2@5.35) 11-5-90-2#3-i-2.5-13-13	69123	84234	0.82	47863	1.44
13	(2@5.35) 11-5-90-6#3-i-2.5-13-13	89748	98506	0.91	58245	1.54
14	(2@5.35) 11-5-90-6#3-i-2.5-18-18	121605	131625	0.92	76754	1.58
15	(4@6) 5-8-90-5#3-i-2.5-6-6 [‡]	31152	30393	1.02	19081	1.63
16	(3@3) 8-8-90-5#3-i-2.5-9-9	39762	59031	0.67	34805	1.14
17	(3@4) 8-8-90-5#3-i-2.5-9-9	36559	57694	0.63	33002	1.11
18	(4@3) 8-8-90-5#3-i-2.5-9-9	31441	55619	0.57	34405	0.91
19	(4@4) 8-8-90-5#3-i-2.5-9-9	29484	56957	0.52	34096	0.86
20	(3@5.35) 11-5-90-2#3-i-2.5-13-13	57921	83326	0.70	46763	1.24
21	(3@5.35) 11-5-90-6#3-i-2.5-13-13	66178	90872	0.73	53313	1.24
22	(3@5.35) 11-5-90-6#3-i-2.5-18-18	111867	121174	0.92	70247	1.59

^a Eq. (3.2)

^b Eq. (4.13)

Table C.7 Test-to-calculated ratios for specimens without confining reinforcement from other researchers

	Specimen	T lb	Descriptive Equation ^a		Design Equation ^b		
			T_h lb	T/T_h	T_h lb	T/T_h	
Marques and Jirsa (1975)	1	J7-180-12-1-H	36600	40270	0.91	33122	1.11
	2	J7-180-15-1-H	52200	51904	1.01	42165	1.24
	3	J 7- 90 -12 -1 - H	37200	39724	0.94	32734	1.14
	4	J 7- 90 -15 -1 - H	54600	54051	1.01	43664	1.25
	5	J 7- 90 -15 -1 - L	58200	54722	1.06	44131	1.32
	6	J 7- 90 -15 -1 - M	60000	55534	1.08	44695	1.34
	7	J 11 - 180 -15 -1 - H	70200	69321	1.01	55026	1.28
	8	J 11- 90 -12 -1 - H	65520	53237	1.23	42850	1.53
	9	J 11- 90 -15 -1 - H	74880	71519	1.05	56527	1.32
	10	J 11- 90 -15 -1 - L	81120	70877	1.14	56089	1.45
Pinc et al. (1977)	11	9-12	47000	47313	0.99	38399	1.22
	12	9-18	74000	77820	0.95	61403	1.21
	13	11-24	120120	119254	1.01	91900	1.31
	14	11-15	78000	73563	1.06	57917	1.35
	15	11-18	90480	87989	1.03	68801	1.32
	16	11-21	113880	108654	1.05	83751	1.36
Hamad et al. (1993)	17	7-90-U	25998	34900	0.74	19500	1.33
	18	7-90-U'	36732	43300	0.85	23500	1.56
	19	11-90-U	48048	59100	0.81	27400	1.75
	20	11-90-U'	75005	73300	1.02	33000	2.27
	21	11-180-U-HS	58843	79700	0.74	35500	1.66
	22	11-90-U-HS	73788	79700	0.93	35500	2.08
Ramirez & Russel (2008)	23	I-1	30000	28800	1.04	15800	1.90
	24	I-3	30000	31800	0.94	17200	1.74
	25	I-5	30500	32100	0.95	17400	1.75
	26	I-2	88000	81200	1.08	34300	2.57
	27	I-2'	105000	104900	1.00	43300	2.42
	28	I-4	99100	89500	1.11	37300	2.66
	29	I-6	114000	90300	1.26	37600	3.03
Lee & Park (2010)	30	H1	86345	81600	1.06	41900	2.06
	31	H2	76992	59000	1.30	30900	2.49

^a Eq. (3.2)

^b Eq. (4.13)

Table C.8 Test-to-calculated ratios for specimens with hooked bars embedded in walls

	Specimen	<i>T</i> lb	Descriptive Equation ^a		Design Equation ^b		
			<i>T_h</i> lb	<i>T/T_h</i>	<i>T_h</i> lb	<i>T/T_h</i>	
Johnson & Jirsa (1981)	1	4-3.5-8-M	4400	5459	0.81	5050	0.87
	2	4-5-11-M	12000	9879	1.21	8838	1.36
	3	4-5-14-M	9800	9879	0.99	8838	1.11
	4	7-5-8-L	13000	11270	1.15	10094	1.29
	5	7-5-8-M	16500	13450	1.23	11756	1.40
	6	7-5-8-H	19500	14128	1.38	12265	1.59
	7	7-5-14-L	8500	11270	0.75	10094	0.84
	8	7-5-14-M	11200	13009	0.86	11422	0.98
	9	7-5-14-H	11900	14128	0.84	12265	0.97
	10	7-7-8-M	32000	21552	1.48	18352	1.74
	11	7-7-11-M	27000	21552	1.25	18352	1.47
	12	7-7-14-M	22000	22812	0.96	19273	1.14
	13	9-7-11-M	30800	24775	1.24	20878	1.48
	14	9-7-14-M	24800	26190	0.95	21902	1.13
	15	9-7-18-M	22300	24886	0.90	20959	1.06
	16	7-8-11-M	34800	27158	1.28	22725	1.53
	17	7-8-14-M	26500	25074	1.06	21213	1.25
	18	9-8-14-M	30700	31180	0.98	25825	1.19
	19	11-8.5-11-L	37000	30046	1.23	25366	1.46
	20	11-8.5-11-M	51500	36735	1.40	30165	1.71
	21	11-8.5-11-H	54800	38113	1.44	31138	1.76
	22	11-8.5-14-L	31000	30046	1.03	25366	1.22
	23	11-8.5-14-M	39000	36624	1.06	30086	1.30
	24	11-8.5-14-H	45500	38113	1.19	31138	1.46
	25	7-7-11-M	24000	20547	1.17	17612	1.36
	26	7-7-11-L	22700	19185	1.18	16601	1.37
	27	11-8.5-11-M	38000	34329	1.11	28454	1.34
	28	11-8.5-11-L	38001	32054	1.19	26821	1.42
	29	7-5-8-M	38002	20355	1.87	17473	2.17
	30	7-5-14-M	38003	20355	1.87	17473	2.17

^a Eq. (3.2)

^b Eq. (4.13)

